



**G.C.E. (Advanced Level)**



# **Biology**

**Grade 12  
Resource Book**

Department of Science  
Faculty of Science and Technology  
National Institute of Education  
[www.nie.lk](http://www.nie.lk)

**G.C.E. (Advanced Level)**

**Biology**

**Grade 12  
Resource Book**

Department of Science  
Faculty of Science and Technology  
National Institute of Education  
[www.nie.lk](http://www.nie.lk)

**Biology**  
**Resource Book**  
Grade 12

© National Institute Of Education  
First Print – 2017

Department of Science  
Faculty of Science & Technology  
National Institute of Education

***Message from the Director General***

The National Institute of Education takes opportune steps from time to time for the development of quality in education. Preparation of supplementary books for respective subjects is one such initiative.

The additional reading book has been composed by the National Institute of Education to implement grades 12 and 13 syllabi and Teachers' Guides successfully in the classroom.

It is our behalf that provision of essential staff relating to respective syllabi by this additional book will facilitate learning the relevant subject stream.

I wish to express my gratitude to the NIE staff and external experts who made their academic contribution to make this material available to you.

**Dr. (Mrs.) T. A. R. J. Gunasekara**  
Director General  
National Institute of Education  
Maharagama.

### ***Message from the Director***

From 2017, a rationalized curriculum is in effect for the G.C.E (A/L) in the education system in Sri Lanka. It means updating the curriculum that was in implementation.

In this effort, revisions were made in the content, form and curricular materials of the G.C.E (A/L) subjects Physics, Chemistry and Biology and in concurrence to that, certain changes in the learning teaching methodology, evaluation and assessment were expected. The volume of the subject matter in the curriculum was largely reduced and several alterations in the learning teaching sequence were also made. A new teachers' hand book was introduced in place of the old curricular material, the teachers' instruction manual.

The teachers' instruction manual contained a line-up of subject matter expected to be learnt but the newly introduced teacher's hand book doesn't accommodate any subject matter. Yet, it provides a guideline for teachers to mould the learning events and for evaluation. Though the teacher's hand book implicitly enunciates the limits of the subject by way of the learning outcomes, the teachers' hand book only is not sufficient to identify holistically the confines of the facts. Thus emerged the need of a resource book which simply describes the subject content. This book comes to you as a result of an attempt to fulfill that requirement.

When implementing the previous curricula, the use of internationally recognized standard textbooks published in English has been an imperative for Advanced Level Science subjects. But, the contradictions of facts related to subject matter and inclusion of material beyond the limits of the local curriculum in them, usage of those books was not an easy task for teachers and students.

This book, offers students an opportunity to study the relevant subject content in the mother tongue within the limits of the local curriculum. It also provides both students and teachers a source of reliable information expected by the curriculum dispensing with seedling information from various print media and extra classes.

This book authored by specialist subject teachers and university lectures is presented to you after the approval of the Academic Affairs Board and the Council of the NIE. Thus it can be recommended as a material of high standard.

**Mr. R. S. J. P. Uduporuwa**  
Director  
Department of Science

### Guidance

**Dr.(Mrs.)T.A.R.J. Gunasekara**  
**Director General**  
*National Institute of Education*

### Supervision

**Mr. R.S.J.P. Uduporuwa**  
*Director, Department of Science*  
*National Institute of Education*

### Subject Leadership

**Miss. P.T.M.K.C. Tennakoon**  
*Assistant Lecturer, Dept. of Science*  
*National Institute of Education*

### Internal Resource Contribution

**Mrs. H.M. Mapagunarithna**  
*Senior Lecturer*  
*National Institute of Education*

**Mrs. D.A.H.U. Sumanasekara**  
*Assistant Lecturer*  
*National Institute of Education*

**P. Atchuthan**  
*Assistant Lecturer*  
*National Institute of Education*

### Editorial Panel

- |                                  |   |
|----------------------------------|---|
| <b>Prof. B.G.D.N.K.de Silva</b>  | - Senior Professor of Molecular Biology,<br>University of Sri Jayawardanepura - (Unit 02,03)                  |
| <b>Prof. S. Abeysinghe</b>       | - Head of the Department, Department of Botany<br>University of Ruhuna - (Unit 02,03,04)                      |
| <b>Prof. S. Hettiarachchi</b>    | - Senior Professor , Department of Biological<br>Sciences, University of Rajarata - (Unit 02,03,04)           |
| <b>Prof. R.A.S.P. Senanayake</b> | - Head of the Department, Department of<br>Botany, University of Kelaniya - (Unit 03,04)                      |
| <b>Prof. D.D. Wickramasinghe</b> | - Head of the Department, Department of<br>Zoology, University of Colombo- (Unit 02)                          |
| <b>Prof. A. Pathirathna</b>      | - Senior Professor, Department of Zoology and<br>Environmental Management<br>University of Kelaniya (Unit 05) |
| <b>Dr.P.L. Hettiarachchi</b>     | - Senior Lecturer, Department of Biological<br>Sciences, University of Rajarata (Unit 04)                     |
| <b>Dr. W.A.M. Daundesekara</b>   | - Senior Lecturer, Department of Botany,<br>University of Peradeniya-(Unit 04)                                |
| <b>Dr. S. Kumburegama</b>        | - Senior Lecturer, Department of Zoology,<br>University of Peradeniya -(Unit 05)                              |

### External resource contribution

- Mrs.P.H.N. Kulathilake** - SLTS-I, Devi Balika Vidyalaya, Colombo 08.  
**Mrs. B. Ganeshadas** - SLTS-I, D.S.Senanayake College, Colombo 08  
**Mrs. P.A.K.Perera** - SLTS-I (Rtd),  
**Mrs. H.L. Hemanatha** - SLTS-I ,Royal College, Colombo 07  
**Mrs. M.S.J. Jayasooriya** - SLTS- Ladies College, Colombo 07  
**Mrs. M.R.P.R Basnayake** - SLTS-I (Rtd) , St.Anne’s College, Kurunegala  
**Mr. A. Illaperuma** - SLTS-I(Rtd)  
**Mrs. H.A.S.G. Perera** - SLTS-I , Sirimawo Bandaranayake College,  
Colombo -07  
**Mrs. A.M.S.D. N. Abeyakoon** - SLTS-I (Rtd) , St. Anthony’s Girls’ College , Kandy  
**Mrs. S.D.P.Bandara** - SLTS-I Rtd), Dharamaraga College, Kandy  
**Mrs. J.A. J.Hanee** - SLTS-I Zahira College, Gampola  
**Mr. W.G. Pathirana** - SLTS-I Rahula College, Matara  
**Mrs. C.V.S. Devotta** - SLTS-I ,Dammissara College, Natthandiya  
**Mr. R. Rupasinghum** - SLTS-I,

### Language Editing

Dr. Chandra Amarasekara

### Diagrams

Mrs. N.R.D. Dahanayake- Teacher,  
Lyceum International school, Nugegoda

### Cover & Type setting

Mrs. R. R. K. Pathirana  
Technical Assitant- NIE

### Supporting Staff

Mrs.Padma Weerawardana -N.I.E  
Mr. Mangala Welipitiya - N.I.E  
Mr. Ranjith Dayawansa - N.I.E

## Content

Message of the Director General, NIE	iii
Message of the Director Department of Science , NIE	iv
Team of Resource Persons	v-vi
<b>Unit 01-Introduction to Biology</b>	
Nature scope and importance of biology with reference to challenges faced by the mankind	01
The nature and the organizational patterns of the living world	04
<b>Unit02- Chemical and cellular basis of life</b>	
Elemental composition of organisms	07
Physical and chemical properties of water important for life	07
Chemical nature and functions of main organic compounds of organisms	09
Contribution of microscope to the expansion of knowledge on cells and cellular organization	22
Historical background of the cell and analyses the structure and functions of the sub cellular units	24
The cell cycle and the process of cell division	39
The energy relationships in metabolic processes	49
The role of Enzymes in regulating metabolic reactions	51
Photosynthesis as an energy fixing mechanism	58
Cellular respiration as a process of obtaining energy	67
<b>Unit 03-Evolution and diversity of organisms</b>	
The theories of origin of life and natural selection to analyze the process of evolution of life	72
Hierarchy of taxa on scientific basis	77
The diversity of organisms within the Domain Bacteria	82
The diversity of organisms within the kingdom Protista	84
The diversity of organisms within the kingdom Plantae	86
The diversity of organisms within the kingdom Fungi	94
The diversity of organisms within the kingdom Animalia	96
The characteristic features to study organisms belonging to phylum Chordata	103
<b>Unit 04- Plant form and function</b>	
Structure, growth and development of plants	106
plant tissues systems	109
Growth and development process of a plant	115
The shoot architecture and light capture	120
The process of gaseous exchange in plants	121



Acquisition of water and minerals	126
Process involved in transport of materials in phloem	132
Processes of water loss in plants	134
The modes of nutrition of plants	137
Nutritional requirements for the optimal growth of plants	138
Trends in life cycles, to relate the adaptations of plants for a terrestrial life	141
Structures and functions associated with sexual reproduction in flowering plants	146
Responses of plants to different stimuli	150
The role of plant growth substances/regulators/hormones in response to different	152
Response of plants to some biotic and abiotic stresses	154

### **Unit 05- Animal form and function**

Relate the structure of animal tissues to their functions	156
Nutrition in animals	163
Human digestive system to its functions	165
Circulatory systems in animals	181
Basic plan of blood circulatory system and lymphatic	185
Gas exchange in animals	200
Immunity	212
Osmoregulation and excretion	222

01

## Introduction to Biology

### **Nature scope and importance of biology with reference to challenges faced by the mankind**

**B**iology is a Science which is focused on studying of living organisms. (Bios- Life, logos "study of")

The concept of "LIFE" is not easy to define. Still scientists are unable to provide an acceptable definition for life.

"Life" is something special and unique which cannot be explained using laws of chemistry and physics.

Biology is a subject which is very complex and vast. Hence for the convenience of studying, it has been divided into three primary branches: Zoology (the study of animals), Botany (study of plants) and Microbiology (study of microorganisms). Some areas of study in these branches:

- Cell Biology (studying cells)
- Histology (studying tissues)
- Anatomy (studying about gross structure of the body)
- Physiology (studying function)
- Biochemistry (studying biological molecules)
- Genetics (studying inheritance)
- Ecology (studying environment)

## Issues pertaining to Biology

### Understanding biological Diversity

At present our planet is rich in diversity. Life on earth formed around 3.8 billion years ago. The first formed organisms are believed to be heterotrophic, anaerobic prokaryotes. Since then the evolutionary process resulted in the extensive biodiversity which exists in the biosphere now.

Scientists assume, based on their studies that there are about 10 to over 100 million species in the world. There is a dynamic relationship between living world and the inanimate world and each and every organism has a specific role in the environment for existence of the Biosphere.

The variety of life on earth, the number of species of plants, animals and microorganisms, the diversity of genes in these species, the different ecosystems on the earth such as deserts, rainforests and coral reefs are all part of a biologically diverse earth.

### Understanding the human Body and its functions

When studying biology, especially by studying histology, anatomy of the human body, one can gain the knowledge about the structure of the organs. This results in understanding and appreciation of the organization of the human body and understanding the functions of different organ systems and the relationship between structure and functions.

### Sustainable use and Management of natural resources and Environment

Natural resources are sources of materials and energy found naturally which are used in everyday life and for economic development.

These natural resources are limited on earth. Due to the increase of growth rate of human population, overuse of natural resources is taking place. It causes threat of depletion of natural resources.

Due to over exploitation of natural resources, various environmental problems arise such as;

- Environmental pollution
- Loss of Biodiversity
- Desertification

Hence to overcome the above problems management of natural resources and Environment should be practiced. Knowledge of Biology is useful to bring about remedies for the above problems.

### Sustainable Food production

Sustainable food production is the production of sufficient amounts of food for the

human population using environmentally safe methods.

The current human population is about 7 billion and expected to be double in less than 40 years. Therefore, for the survival of human beings sustainable food production is necessary.

To maintain sustainable food production following methods can be applied, which are based on knowledge in biology.

- Production of high yielding varieties of plants and animals.
- Production of disease resistant plants and animal varieties.
- Improve the post harvest technological methods.

### **Understanding plant life**

Plants are the primary producers in the world. All the animals depend directly or indirectly on plants. Therefore understanding plant life is important. As the time human population is increasing we need to increase the productivity. Therefore understanding plant function and biology is important to produce high yielding plants, disease resistant plants, etc.

### **Understanding diseases and causes**

To maintain healthy human body one should have the knowledge of causes of the diseases and their effects.

Some dangerous diseases which exist in current world are non communicable diseases such as cancers, heart diseases, diabetes, chronic renal diseases and communicable diseases such as dengue, AIDS, etc.

Cancers- causes for this is not fully understood yet. Cancers are one of the leading causes of death .

AIDS- is a viral disease which is a serious and growing health problem worldwide.

Heart diseases- This is also a serious and growing health problem worldwide. Causes are not fully understood yet.

Chronic renal diseases- In Sri Lanka, recentlyCKDu has become a serious health problem.

Currently scientists are working on prevention, remedial measures and cures for such diseases.

**Solving some legal and ethical issues**

Knowledge and application of biological concepts is important in solving some legal issues, such as parentage testing, in criminal investigations and to solve immigration disputes.

DNA fingerprinting is used in above circumstances.

**The nature and the organizational patterns of the living world**

In accordance with different criteria we can see a diversity among living organisms. Organisms are diverse based on size, shape, form and habitats.

- Living organisms show a wide range of variation in size, shape, form and habitat.
- Size – Bacteria – 0.25  $\mu\text{m}$  – 2  $\mu\text{m}$  to Giant Sequoia (Giant Red Wood)– 100m
- Shape – Organisms are diverse in shape, Ex: Cylindrical (earth worm), streamline shape(birds, fish)
- Form – Unicellular (Amoeba), multicellular (any plant or animal)
- Habitat – Terrestrial (Rat), aquatic (Fish), arboreal (Loris), aerial(Birds)

**Characteristics of organisms**

In order to survive, each organism whether simple or complex must be able to perform certain functions. Following features are the characteristics of organisms.

**(i) Order and organization**

From molecular level to biosphere there is an order and organization in organisms to perform their biological activities efficiently.

Lower level components are organized in a methodical pattern in upper level to make it most efficient.e.g: plant leaf and human eyes.

**(ii) Metabolism**

The sum of all chemical activities taking place in an organism is its metabolism. It includes catabolic reactions and anabolic reactions.

**(iii) Growth and development**

All organisms begin their life as a single cell. During growth an irreversible increase in dry mass occurs, which is characterized only by the living. Irreversible changes that occur during the life span of an organism is development. Growth and development are two consequent processes that happen in the life span of organisms.

**(iv) Irritability and coordination**

Irritability is the ability to respond to stimuli from both internal and external environment. Movement of organisms occurs as a result of irritability and coordination. In animals

this happens as a result of coordinated efforts of nervous, hormonal, muscular and skeletal systems

**(v) Adaptation**

Adaptation is a peculiarity of structure, physiology or behavior that promotes the likelihood of an organism's survival and reproduction in a particular environment. E.g: Sunken stomata in Xerophytes, Viviparity in some mangroves, Splayed out foot in camels.

**(vi) Reproduction**

Ability to produce offspring for continuous existence of species

**(vii) Heredity & Evolution**

Organisms have genes that pass from one generation to the next and control specific physiological, morphological and behavioral characters of organisms.

Ability of organisms to change over time as a result of genetic modification is evolution

Many non living entities may have one or more of these characteristics but not all of them e.g., crystals grow, waves move but only living organisms display all these characteristics simultaneously or at some point during their life cycle.

By considering this it can be said that these are occurring in single celled organisms as well as highly complex organisms such as humans and Anthophytes (flowering plants).

**Hierarchical levels of organization of living things**

The cell is the basic structural and functional unit of life. Some organisms are unicellular while others are multicellular. Cell is composed of several organelles which are formed by different organic molecules. Then hierarchical levels of organization of living things can be constructed by using relevant examples at each level.

Molecules, Organelles, Cells, Tissues, Organs, Organ systems, Organisms, Populations, Communities, Ecosystems, Biosphere

## 02

**Chemical and cellular basis of life****Elemental composition of living matter**

There are about ninety two elements naturally occur in earth's crust. Of which, about 20-25% elements are essential to continue healthy life and reproduction. (about 25- elements are essential for humans and about 17 for plants).

Oxygen (O), Carbon (C), Hydrogen (H), and Nitrogen (N) make up 96% of living matter.

Calcium (Ca), Phosphorous (P), potassium (K) and sulphur (S)- make up most of the remaining 4% of the mass of the organism.

In humans, C, H, O, N- accounts for 96.3% of the body mass and Ca, P, K, S, Na, Cl, Mg and trace elements accounts for the remaining 3.7%. (e.g. B (Boron), Co (Cobalt), Cu (Copper), Cr (Chromium), F (Fluorine), I (Iodine), Fe (Iron),

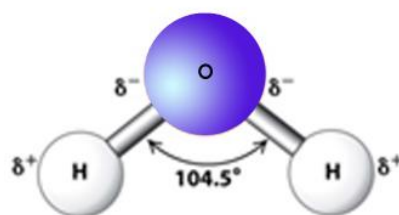
Mo (Molybdenum), Mn (Manganese), Se (Selenium), Si (Silicon), Sn (Tin), V (Vanadium), Zn (Zinc)

**Physical and chemical properties of water important for life**

Water is a vital inorganic molecule; life could not exist on this planet without water. It is important due to following reasons,

1. Vital chemical constituent of living cell
2. Provides a biological medium for all organisms

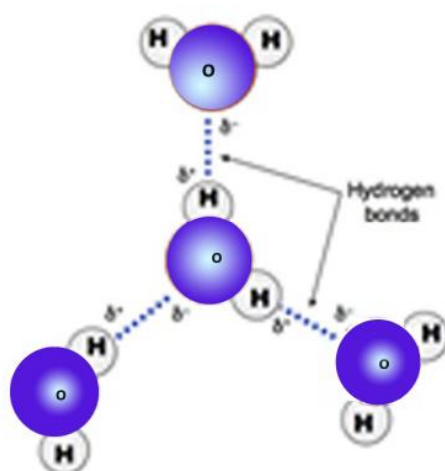
Most of above properties are based on the chemical structure of water molecule. Physical and chemical properties of water molecule provide the ability to render the vitality. Water molecule is a small, polar and angular molecule.



$\delta^+$  partial positive  
 $\delta^-$  partial negative

*Fig 2.1: Chemical structure of the water molecule*

Polarity is an uneven charge distribution within a molecule. In water molecule, oxygen atom is slightly negative and hydrogen atom is slightly positive. Weak attractions between the slightly polar hydrogen atom of one water molecule and the slightly polar oxygen atom of adjacent water molecule are known as hydrogen bonds. These hydrogen bonds play a major role in maintaining all the properties of water.



*Fig 2.2: Hydrogen bonding in water*

The properties of water arise due to attractions of different water molecules. When the water is in liquid form its H bonds are very fragile. H bonds form, break and reform with great frequency.

Four major properties of water to maintain life on earth

- Cohesive behavior
- Ability to moderate temperature
- Expansion upon freezing
- Versatility as a solvent

Properties of water related to functions



### 1. Cohesive behavior

Attraction between water molecules due to hydrogen bonding is known as cohesion. Attraction between water molecules and other substances are known as adhesion. Both of the above properties of water allow it to act as a transport medium.

Due to cohesion between water molecules, water and dissolved substances such as minerals and nutrients transport through vascular tissues, xylem and phloem against gravity.

Adhesion between water molecules and cell walls also helps in conduction of water and dissolved substances.

Water has a high surface tension. This ability is given to water molecules, due to cohesion between the water molecules. Therefore, in an aquatic system, upper surface water molecules are attracted by lower surface molecules and it forms a water film. Small insects e.g. water skaters can walk on the surface of a pond.

### 2. Ability to moderate temperature

Water can absorb or release a relatively high amount of heat energy by a slight change in its own temperature.

Due to the high specific heat, water will function as thermal buffer in living system and aquatic bodies during the temperature fluctuations on earth.

Due to the high heat of vaporization, with the minimum loss of water an organism can release much heat energy. Therefore, body surface of an organism maintained as cool surface.

e.g. Prevent from overheating.

Evaporation of sweat from human skin helps to maintain the body temperature at constant level.

Transpiration in plants keeps the plant body surface as a cool surface and prevent from becoming too warm in the sunlight.

### 3. Expansion upon freezing

Generally, in an increase in temperature of any substances, reduces their density and on the other hand, in a decrease in temperature increases their density. When the temperature of water falls below 4 °C, it begins to freeze and forms a crystalline lattice called ice cubes. Therefore water has the maximum density at 4°C. Hence, ice floats on the surface of water bodies. It is an important property of water in polar regions, where, organisms in aquatic bodies can survive during the winter.

#### 4. Versatility as a solvent

This ability is given to water due to their polarity. Polar molecules (e.g. Glucose), non polar ionic (e.g. NaCl), both polar and ionic (e.g. lysozymes) can dissolve in water, because water molecules surround each of the solute molecules and form hydrogen bonds with them. Solubility depends on polarity and not in their ionic nature.

### Chemical Nature and Functions of Main Organic Compounds of Organisms

#### Carbohydrates

Most abundant group of organic compound on earth is carbohydrates. Major elemental composition is C, H, and O. Hydrates of carbon contain the same proportion of H: O which equals to 2:1 as in water. General formula is  $C_x(H_2O)_y$ . Three major groups of carbohydrates are monosaccharides, disaccharides and polysaccharides.

Generally carbohydrates include sugars (monosaccharides and disaccharides) and polysaccharides.

#### Monosaccharides

The simplest form of carbohydrates having general molecular formula as  $(CH_2O)_n$  are monosaccharide. Where C varies from 3-7. All monosaccharide are reducing sugars, water soluble and occur in crystalline form.

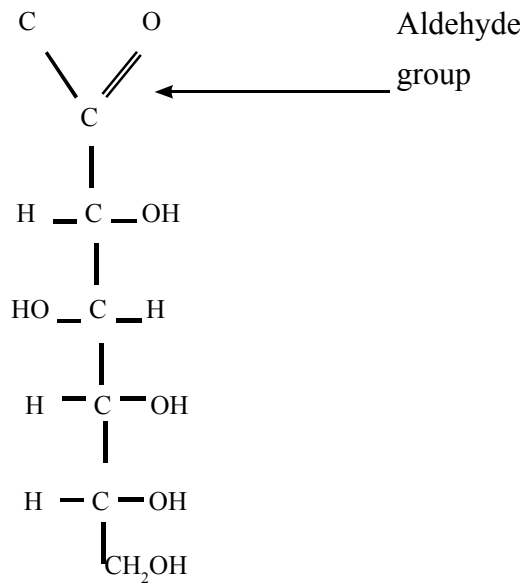
According to the number of carbon atoms, they are named as;

- 3C- Triose e.g. Glyceraldehydes (Phosphoglyceraldehyde is a derivative of Triose)
- 4C- Tetroses.g. Erythrose (rare in nature)
- 5C- Pentoses.g. Ribose, Deoxyribose, Ribulose (RUBP is a derivative of ribulose)
- 6C- Hexoses e.g. Glucose, Fructose, Galactose

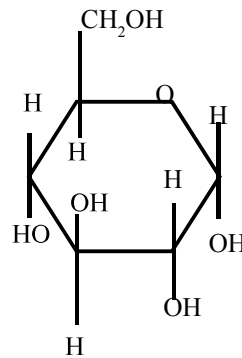
According to the type of carbonyl (Keto, aldo)group, they are classified as;

- a. Aldoses-glucose, galactose
- b. Ketoses-fructose

Aldose

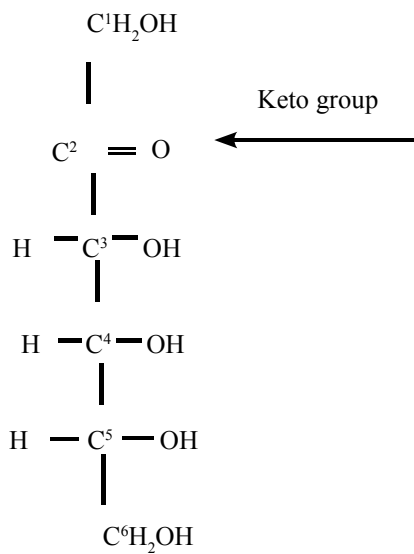


*Fig 2.3: Solid form of glucose*

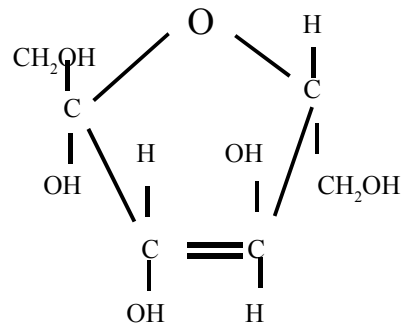


*Fig 2.4: Aqueous form of Glucose molecule*

Ketose



*Fig 2.5: Solid form of fructose*



*Fig 2.6: Aqueous form of fructose*

In aqueous media some monosaccharides are in ring form (No need to memorize the chemical structures)

## Disaccharides

They are sugars formed by joining two monosaccharides by a glycosidic bond.

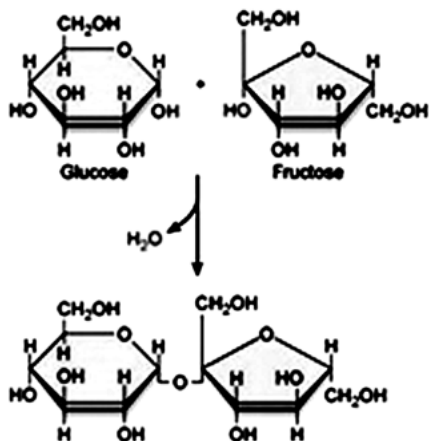


Fig 2.7: Formation of sucrose

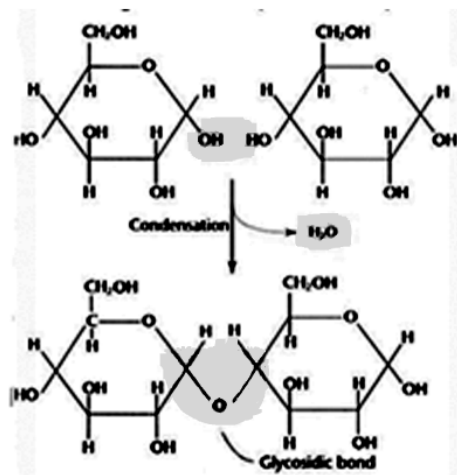
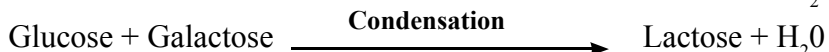
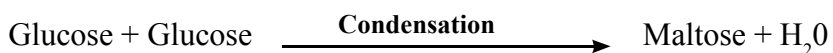


Fig 2.8: Formation of maltose

(no need to memorize the chemical structures)

Glycosidic bond is formed by removal of a water molecule from two adjacent monosaccharides by a condensation reaction. Water molecule is formed from OH group of one monosaccharide molecule and H from adjoining monosaccharide molecule.



Maltose and lactose are reducing sugars and sucrose is a non reducing sugar.

## Polysaccharides

They are macromolecules and biopolymers. Polysaccharides are made up of few hundred to a few thousand monosaccharide subunits

They are non crystalline, water insoluble, and not considered as sugars.

Some polysaccharides act as storage components where others contribute to the structure of living organisms. Based on their function they are categorized as storage polysaccharides and structural polysaccharides.

- Storage- Starch, Glycogen
- Structural- Cellulose, Hemicellulose, Pectin

Based on their architecture they are categorized as

- Linear forms- Cellulose, Amylose
- Branched forms- Glycogen, Amylopectin, Hemicellulose

**Table 2.1: Major polysaccharides, their monomers and functions**

<b>Polysaccharide</b>	<b>Monomer</b>	<b>Functions</b>
Starch	Glucose	Stored in plants
Glycogen	Glucose	Stored in animals and fungi
Cellulose	Glucose	Component of Cell wall
Inuline	Fructose	Stored in tubers of Dhalia
Pectin	Galacturonic acid	Component of Middle lamella of plant cell wall
Hemicellulose	Pentose	Component of Plant cell walls
Chitin (nitrogen containing polysaccharide)	Glucosamine	Component of Fungal cell walls and exoskeleton of Arthropods

## Functions of carbohydrates

### Monosaccharides

- Energy source
- Building blocks of disaccharides and polysaccharides (disaccharides such as maltose, sucrose and polysaccharides such as starch, glycogen)
- Components of nucleotides (DNA, RNA)

### Disaccharides

- Storage sugar in milk- Lactose
- Translocation in phloem –Sucrose
- Storage sugar in sugarcane- Sucrose

### Polysaccharides

#### a.) Storage polysaccharides-

- starch stores glucose as energy source in plants and chlorophytes
- glycogen stores glucose as energy source in animals and fungi
- inulin stores fructose as energy source in Dahlia tubers

b.) structural polysaccharides-

- Cellulose in the cell walls of plants and chlorophytes
- Pectin in the middle lamella of plant tissues.
- Hemicellulose in cell walls of plants.
- Peptidoglycan in the cell walls of prokaryotes.
- Chitin in the cell walls of fungi and in exoskeleton in Arthropods.

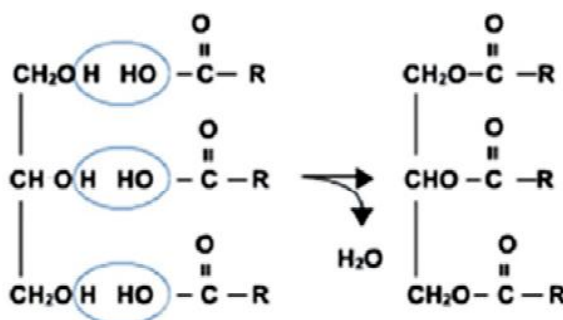
### Lipids

- Diverse group of hydrophobic molecules
- Large biological molecules but not considered as polymers or macromolecules.
- Consist of C, H, O and H:O ratio is not 2:1. Comparatively more H are present.
- Biologically important types of lipids: Fats, Phospholipids and Steroids.

### Fats

Fats are made up of glycerol and fatty acids; Glycerol belongs to alcohol group having 3 carbons where each of them bear single hydroxyl group. Fatty acids are hydrocarbon chains with long (16-18) carbon skeleton with a carboxyl group at its one terminal.

Fatty acid molecules bind to each hydroxyl group of glycerol by ester bond. Resulting fat molecules are called as triacylglycerol.



*Fig 2.9: Formation of Triacylglycerol*

Hydrocarbon chains of fatty acids contribute to the hydrophobic nature of the fats. Based on the nature of hydrocarbon chains of fatty acids, they are categorized as

- Saturated fats- fats are made up of saturated fatty acids: fatty acids with hydrocarbons having no any double bonds. Usually animal fats come under this category. They are mostly solid at room temperature. e.g: butter
- Unsaturated fats- fats are made up of unsaturated fatty acids- fatty acids with hydrocarbons having one or more double bonds. Usually plant fats come under

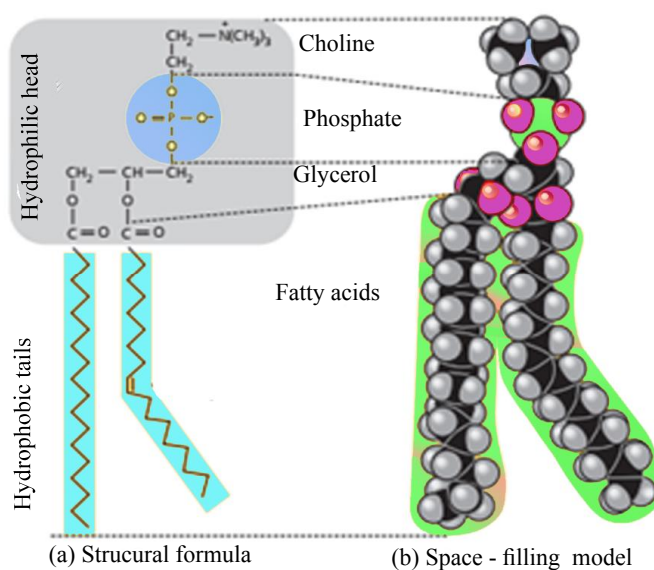
this category. They are mostly liquid in room temperature. e.g: vegetable oils. Unsaturated fats may classify based on the nature of their double bonds. a) *Cis* Unsaturated fat b) *Trans* Unsaturated fat

Consumption of excess saturated fats and trans unsaturated fats contribute atherosclerosis.

### Phospholipids

Phospholipids are major components of the cell membranes. They are composed of two fatty acids and one phosphate group attached to one glycerol molecule. The phosphate group gives the negative electrical charge to the phospholipid molecule. Typically an additional polar molecule or small charged molecule is also linked to the phosphate group e.g. choline.

The two ends of the phospholipids show different behavior. The hydrocarbon tails are hydrophobic while phosphate group and its attachment (head) are hydrophilic.



(no need to memorize the structure)

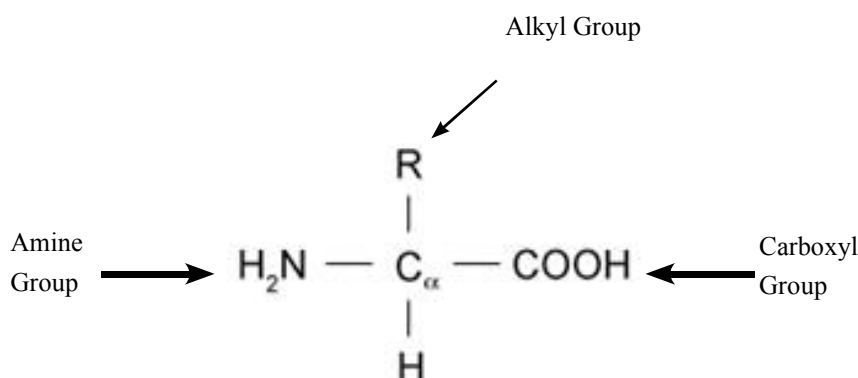
**Fig 2.10: structure of the phospholipid molecule**

### Functions of Lipids

- food reserve as energy source (triglycerides such as fats and oils)
- maintain the fluidity of plasma membrane (phospholipids, cholesterol)
- act as signaling molecules (eg. Hormones) that travel through the body
- found as components of animal cell membrane (cholesterol)

## Protein

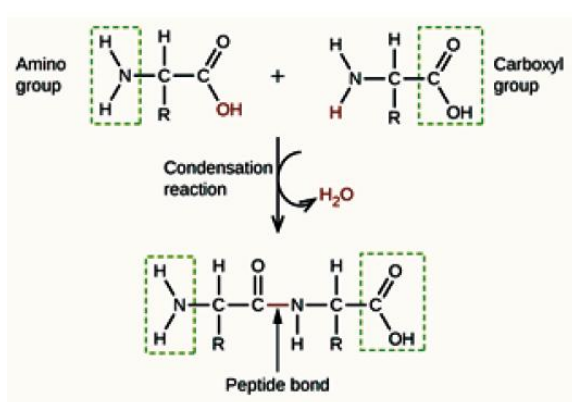
Proteins are made up of amino acids. Twenty different amino acids are involved in the formation of proteins. Elemental composition is C, H, O, N and S. At the centre of the amino acid is an asymmetric carbon atom except in glycine. Each amino acid is composed of an amino group, a carboxyl group, a hydrogen atom and a variable group symbolized by R, which is an alkyl group. In the case of glycine R is replaced by H atom. The R group also called the 'side chain' differs with each amino acid where as the other groups are in the 'back bone' (including the H atom).



*Fig 2.11: Structure of an Amino acid molecule*

Amino acids may have one or more carboxyl groups and amino groups. Amino group has alkaline nature and carboxyl group has acidic nature. When both characteristics are found in one molecule they are known as amphoteric molecules. Therefore, amino acids are amphoteric.

Two Amino acids undergo condensation reaction by removing a water molecule from both and result a bond known as peptide bond;



*Fig 2.12: Formation of peptide bond*



Protein is composed of one or more polypeptide chains which are composed of amino acids.

### Levels of protein structures

There are four levels of structure which play important roles in their functions;

- Primary
- Secondary
- Tertiary
- Quaternary

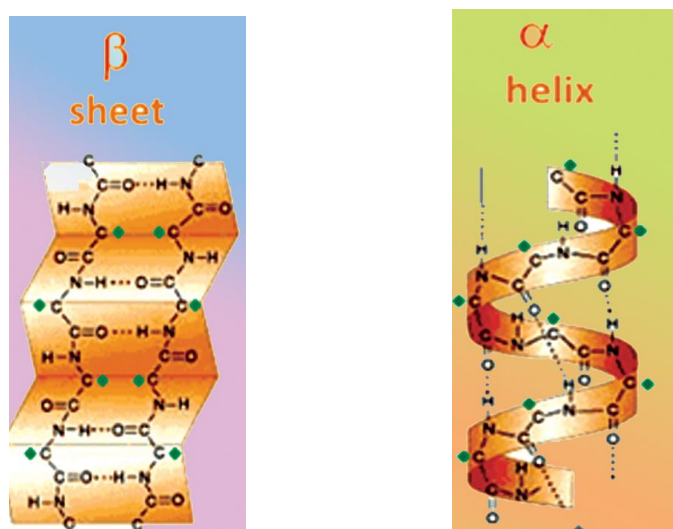
#### a) Primary structure

The unique sequence of linearly arranged amino acids linked by peptide bonds is the primary structure of proteins.

#### b). Secondary structure

The primary structure of a single polypeptide chain coils and folds, as a result of intra molecular hydrogen bonds between the oxygen atoms and the hydrogen atoms attached to the nitrogen atoms, of the same poly peptide chain backbone, to form the secondary structure, which is either  $\beta$  pleated or alpha helical.

- Alpha helix- e.g.Keratin.
- $\beta$  pleated sheet e.g.spider's silk fiber



*Fig 2.13: beta pleated sheet and alpha helix of secondary structures of proteins*

**b) Tertiary structure**

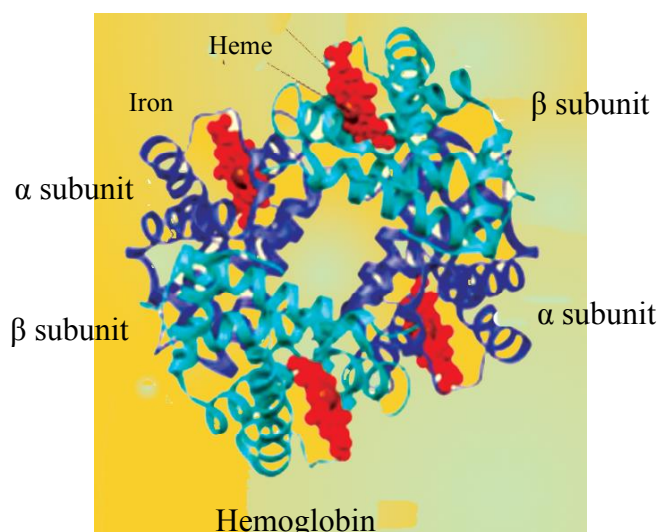
Usually the secondary polypeptide chain bends and folds extensively forming a precise compact unique, functional and three-dimensional shape resulting from following interactions between the side chain/ R-group of amino acids;

- H bonds
- Disulphide bonds
- Ionic bonds
- Van der Waals interactions/ Hydrophobic interactions  
e.g. most of the enzymes, myoglobin, albumin

**c) Quaternary structure**

Aggregation of two or more polypeptide chains involve in the formation of one functional protein. Separate chains are called protein subunits which were held together by inter and intra-molecular interactions.

e.g. Haemoglobin, Collagen



*Fig 2.14: structure of the hemoglobin molecule*

**Denaturation of proteins**

Denaturation of protein is the loss of specific chemical three dimensional shape due to the alteration of weak chemical bonds and interactions.

**Agents affecting the denaturation**

1. High temperature and high energy radiation
2. Strong acids, alkaline and high concentrations of salts
3. Heavy metals
4. Organic solvents and detergents

## Functions of the proteins

Table 2.2 Functions of Proteins

Type of protein	Example	Functions
Catalytic protein	Pepsin, Amylase	Catalyze biochemical reaction
Structural protein	Keratin,	Prevent desiccation
	Collagen	Provide strength and support
Storage	Ovalbumin	Storage protein in egg
	Casein	Storage protein in milk
Transport	Haemoglobin	Transport O <sub>2</sub> and CO <sub>2</sub>
	Serum albumin	Transport fatty acids
Hormones	Insulin	Regulate blood glucose level
	Glucagon	
Contractile/ Motor	Actin/Myosin	Contraction of muscle fibres
Defensive	Immunoglobins	Eliminate foreign bodies

## Nucleic acids

Nucleic acids are Polymers exist as polynucleotides made up of monomers called nucleotides. They contain C, H, O, N and P. Nucleic acids are macromolecules, biopolymers. There are two types of Nucleic acids: DNA (Deoxyribo nucleic acids) and RNA (Ribonucleic acids).

## Structure of nucleotides

Nucleotides have 3 components; namely pentose sugar, nitrogenous base and a phosphate group

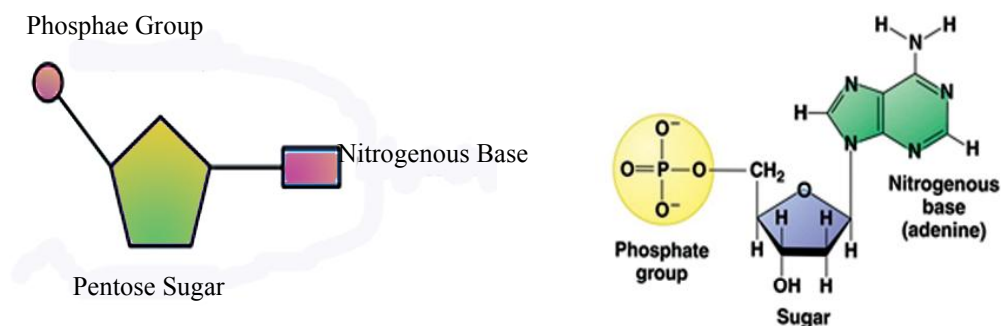


Fig 2.15: Structure of nucleotides (no need to memorize chemical structures)

A nucleotide without a phosphate group is called a nucleoside. e.g. Adenosine, Guanosine

**Pentose sugar**

Pentose sugars are two types; namely Deoxy ribose and ribose (in deoxyribose one oxygen atom is less than in ribose)

**Nitrogenous bases**

There are two major groups of nitrogenous bases:

1. Purines- larger in size with two rings
2. Pyrimidines- smaller in size with a single ring

In purines there are two types; namely Adenine, Guanine. In pyrimidines there are three types, Thymine, Uracil and Cytosine. Bases are commonly represented by letters A, G, T, U and C respectively.

**Phosphate group**

It gives the nucleic acids the acidic nature.

**Formation of nucleic acids**

Millions of nucleotides join by phospho-di-ester bond to form polynucleotide chains by condensation between the –OH group of the phosphate of one nucleotide with the –OH attached to 3rd carbon of pentose sugar of the other. These bonds result in a backbone with a repeating pattern of sugar-phosphate units. Nucleic acids are linear polymers of nucleotides. There are two kinds of nucleic acids depending on the type of the sugar molecules involved. If the sugar molecule in the nucleotide is deoxyribose, the nucleic acid is (DNA). If the pentose sugar is ribose, then the nucleic acid is RNA. DNA contains Adenine, Thymine, Guanine and Cytosine and RNA contains Adenine, Guanine, Cytosine and Uracil.

**Structure of DNA molecule (Watson and Crick model)**

DNA molecules have two anti-parallel polynucleotide chains that spiral around an imaginary axis, forming a double helix. The two sugar-phosphate backbones run in opposite directions from each other, and the arrangement is referred to as anti-parallel. The sugar phosphate backbones are on the outside of the helix, and the nitrogenous bases are paired in the interior of the helix. The two strands are held together by hydrogen bonds between the paired nitrogen bases.

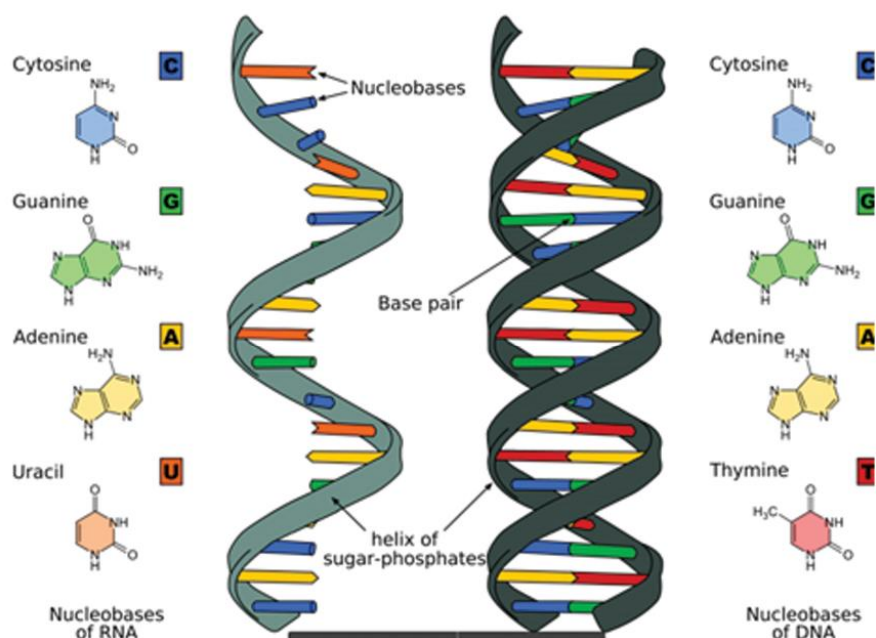
**Base pair rule**

Always a purine base, pairs with a specific, pyrimidine base,

A=T (2 hydrogen bonds)

G≡C (3 hydrogen bonds)

Hence two chains (strands) are said to be complementary to each other. These pairs are known as complementary base pairs. In this original double helical structure, one complete turn consists of ten base pairs as shown in the diagram.



*Fig2.16: The structure of the DNA and RNA molecules (no need to memorize chemical structures)*

### Functions of DNA

- Store and transmit genetic information from one generation to the next generation
- Store the genetic information for protein synthesis

### Structure of RNA

This is normally a single stranded nucleic acid composed of ribo-nucleotides containing bases, Uracil (U), Cytosine (C), Guanine (G), Adenine (A). Complementary base pairing between two RNA molecules or within the same molecule may occur in some. Complementary base pairing facilitates three dimensional shapes essential for their functioning. Adenine binds with Uracil with two hydrogen bonds and Guanine binds with Cytosine with three hydrogen bonds. There are three types of RNA present in cells,

1. Messenger RNA (mRNA)
2. Transfer RNA (tRNA)
3. Ribosomal RNA (rRNA)

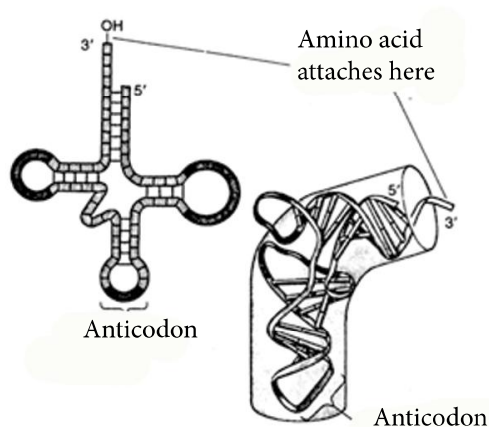
### 1. Messenger RNA

Messenger RNA is a linear molecule and is the least abundant type of RNA in a cells comparatively. There are two functions;

- Copies the genetic information stored in DNA molecule as a sequence of nitrogenous bases
- Transports genetic information from nucleoplasm to the site of protein synthesis (ribosome) through nucleopores

### 2. Transfer RNA (tRNA)

Smallest RNA molecule. Linear, but forms three- looped structure as shown in the diagram.



*Fig 2.17: Structure of the tRNA molecule*

Function - transportation of amino acids to the site of protein synthesis.

### 3. Ribosomal RNA

It is the most abundant type of RNA. rRNA has a complex irregular structure. It provides the site where polypeptide chains are assembled.

### Differences between DNA and RNA

1. DNA is double stranded molecule while RNA is a single stranded molecule.
2. DNA consists of A, T, G and C and absence of U, while RNA consists of A,U, G and C and absence of T
3. Sugar molecule in RNA is ribose, while in DNA it is deoxyribose.

**Nucleotides other than those found in nucleic acids**

ATP, NAD<sup>+</sup>, NADP<sup>+</sup>, FAD and their functions

**Functions of ATP**

- Universal energy carrier

**Functions of NAD<sup>+</sup>**

- Act as a coenzyme
- Act as an electron carrier
- Function as an oxidizing agent during respiration

**Functions of NADP<sup>+</sup>**

- Act as coenzymes
- Act as an electron carrier
- NADP<sup>+</sup> act as a reducing agent in photosynthesis

**Functions of FAD**

- Act as a coenzyme
- Act as an electron carrier

**Contribution of microscope to the expansion of knowledge on cells and cellular organization**

Advancement of the cytology is mostly based on the microscopy. The discovery and early study of cells progressed with the invention of microscope.

**Light microscope**

Visible light is passed through the specimen and then through glass lenses. The lenses refract the light in such a way that the image of the specimen is magnified as it is projected into the eye. The simplest microscope is a single lens.

**The compound light microscope**

Compound light microscopes are commonly used in school laboratories and it is used in medical laboratories as a diagnostic tool.

Resolution power and magnification are important parameters which can be seen in a microscope.

Magnification is ratio of an object's image size to its actual size. Usually the maximum magnification of light microscope is 1000 times the actual size of the specimen)

Resolution power is minimum distance between two points that can be distinguished as separate points (resolution power of light microscope is 0.2 $\mu$ m). It is a measure of

the clarity of the image.

Magnification is limited due to the resolution.

Light from an object (specimen on the slide) passes first through objective lens. Then produce a magnified image.

Above image then acts as an object for the second lens (the eye piece lens) which further magnifies it.

The total magnification is hence the product of the magnification of each lens.

$$\text{Total magnification} = \text{Magnification of objective lens} \times \text{Magnification of objective lens}$$

e.g- .If magnification of Objective lens =  $\times 40$ , eyepiece =  $\times 15$

Total is  $= 15 \times 40 = \times 600$  time magnified

### **The Electron Microscope**

The limitation imposed upon the resolution power of the light microscope by the wavelength of light. The resolution power is inversely proportional to the wavelength. Due to this, scientists considered the use of other forms of radiations with comparatively shorter wavelengths.

As a result, electron microscopes were developed. In electron microscopy, a beam of electrons is focused through the specimen or on to its surface.

This means, that in theory, the electron microscope should be able to magnify objects up to  $1 \times 10^8$  times. In practice, it magnifies just over  $5 \times 10^5$  times.

Electron microscopes have revealed many organelles and other sub cellular structures those were impossible to resolve with the light microscopes.

There are two types of electron microscopes.

1. Transmission electron microscopes (TEM)
2. Scanning electron microscopes (SEM)

### **Transmission electron microscopes**

It is used to study the internal structures of cells. In this microscope, a beam of electrons is passed through a thin, especially prepared slice of material. A very thin specimen is used. Specimens stained with heavy metals which attach more to certain cellular structures than other areas. Image reflects the pattern of electrons passed through the specimen, displays on a screen. While electrons pass through the specimen, more electrons may get displayed in regions where structures were densely stained.



### Scanning electron microscopes

In this instrument, a fine beam of electrons is reflected from the surface of specimen. Specimen is mostly coated with gold prior to observation. Here the specimen scatters many electrons whereas others are absorbed. This instrument is ideal to observe the surface view in three dimensional appearances.

**Table 2.3: Differences between light and electron microscope**

<b>Light Microscope</b>	<b>Electron microscope</b>
Glass lenses are used to focus the light rays	Powerful magnets are used to focus beam of electrons
Image is directly detected by naked eye	Not directly detected by naked eye, micrographs are used
Living and non living objects can be observed	Only non-living objects are observed
Actual color of the object can be observed	Actual color cannot be observed. Images are developed
Dyes used to stain the object	Heavy metals are used to stain the object

## Historical background of the cell and analyses the structure and functions of the sub cellular units

### Cell theory

All organisms are composed of cells.

Recall the hierarchy of life, the levels of organization mentioned earlier. The basic unit which can be called “living” is the cell, which may form a single celled organism (e.g. *Chlamydomonas*, Yeast) or a multi-cellular plant or animal. The cell is the basic structural and functional unit of life.

The level of organization of matter represented by a cell shows all the characteristics of life. Any stage below level of a cell cannot be considered living, whether it is a single celled organism or multi-cellular plant or an animal.

Robert Hooke (1665) examined a cork using simple microscope and gave the term “CELL” to describe the basic units.

Anton Van Leeuwenhook (1650), a contemporary of Robert Hooke, was the first to describe and record living single celled organisms, *Euglena* & bacteria

Matthias Schleiden (1831), a botanist, studying plant tissues concluded that all plants are made up of cells.

Theodore Schwann a zoologist (1839) concluded that animal tissues are also made up of cells.

Rudolf Virchow (1855) showed that all cells arise from pre-existing cells by cell division,

Schleiden, Schwann and Virchow presented the 'Cell Theory' which included the following.

1. All organisms are composed of one or more cells.
2. The basic structural and functional unit of organisms is the cell.
3. All cells arise from pre-existing cells.

### Organization of cells

There are two kinds of cellular organization - Prokaryotic and Eukaryotic

All cells share certain basic features. They are;

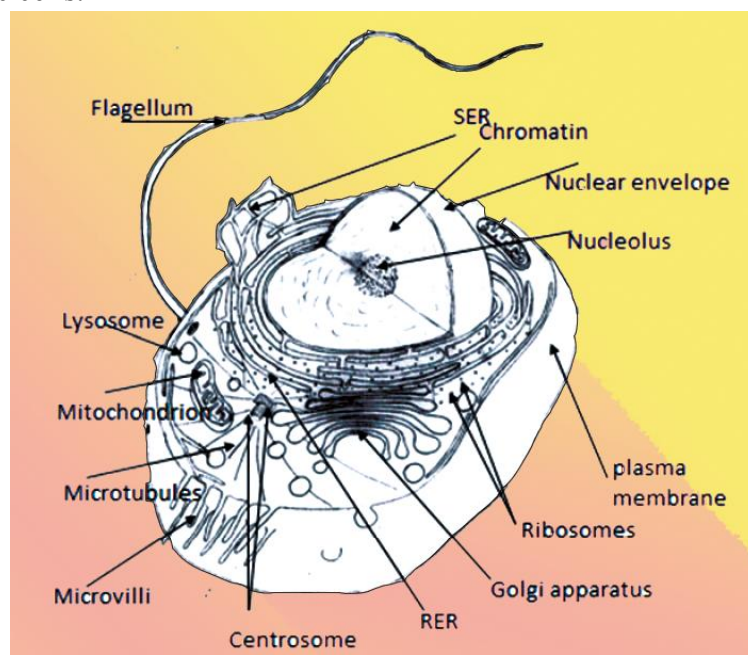
- All cells are bounded by a plasma membrane which is a selective barrier
- Within the cell have, a semifluid, jelly like substance which is called cytosol. Subcellular components are suspended within the cytosol.
- They carry DNA as genetic materials.
- Ribosomes are found in all cells

**Table 2.4: The differences between Prokaryotic cells and Eukaryotic cells**

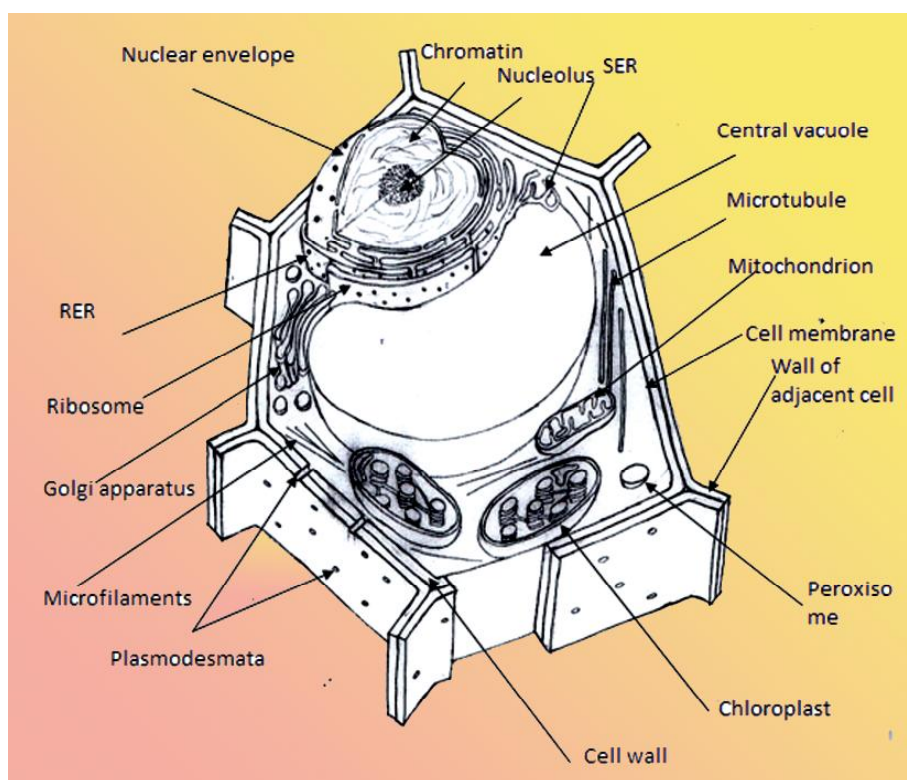
Feature	Prokaryote	Eukaryote
organism	Bacteria, Archaeobacteria	Protists, Fungi, plants, animals
Cell size	Average diameter 1-5 $\mu$ m	10 $\mu$ m-100 $\mu$ m diameter
Form	Mainly unicellular	Mainly multicellular (except most of protista and some fungi are unicellular)
Evolutionary origin	3.5 billion years ago	1.8 billion years ago, evolved from prokaryotes
Cell division	Binary fission, no mitosis and meiosis	Mitosis, meiosis, or both;
Genetic material	DNA is circular and lies free in the cytoplasm. This region is called nucleoid, DNA is naked and not associated with proteins	DNA is linear and contained in a nucleus. DNA is associated with proteins
Type of ribosomes	70s ribosome (smaller)	Both 70s (Mitochondria and Chloroplast) and 80s ribosomes (larger) present (may attach to endoplasmic reticulum)

Organelles	Few organelles, none are surrounded by membrane Internal membranes scarces; if present usually associated with respiration, photosynthesis and N <sub>2</sub> fixation.	Many organelles, membrane bounded organelles present. Great diversity of organelles. e.g. nucleus, mitochondria, chloroplasts bounded by two membranes. e.g. Lysosomes, Vacuole, bounded by single membrane.
Cell walls	Peptidoglycan present in Bacteria and cyanobacteria, polysaccharide and protein present in Archae bacteria	Cell walls of green plants and fungi are rigid and contain polysaccharides; cellulose in plant cell walls and chitin in fungal walls (none in animal cells)
Flagella	Simple, lacking microtubules; extracellular (not enclosed by cell surface membrane) 20nm diameter	Complex, with '9+2' arrangement of microtubules; intracellular (surrounded by cell surface membrane) 200nm diameter
Respiration	Mostly by mesosomes	Mitochondria for aerobic respiration
Photosynthesis	No chloroplasts; takes place on membranes which show no stacking	Chloroplasts containing membranes which are usually stacked into lamellae or grana
Nitrogen fixation	Some have the ability	None have the ability

Bacteria, Cyanobacteria and Achaea are prokaryotic cells. All the other organisms have eukaryotic cells.



**Fig 2.18: Structure of an animal cell**



*Fig 2.19: Structure of plant cell*

### Structures and functions of organelles and other subcellular components

**Plasma membrane:** Plasmamembrane is the outer limit of cytoplasm. All cellular membranes resemble the ultra structure of plasma membrane. In 1972, Singer and Nicolson put forward the fluid mosaic model of cell membrane. It is mainly composed of;

- Phospholipids (most abundant type of lipid in plasma membrane)
- Protein

The Plasma membrane has the following features. It is about 7nm thick. It is mainly made up of a phospholipid bilayer. Phospholipids are amphipathic molecules. The hydrophilic heads of the phospholipids face outwards into the aqueous environment of both inside and outside of the cell.

The hydrophobic hydrocarbon tails face inwards and create a hydrophobic interior.

Plasmamembrane is compared to the fluid mosaic model. Since phospholipid molecules are moveable, they provide the fluid nature to the membrane.

Protein molecules embedded randomly contribute to its mosaic nature.

Some of the protein molecules penetrate all the way through the membrane, called transmembrane proteins and some others penetrate only part of the way into the membrane. These are called **integral proteins**.

Most of the integral proteins are transmembrane proteins which have hydrophilic channels. These act as pores through which ions and certain polar molecules can pass.

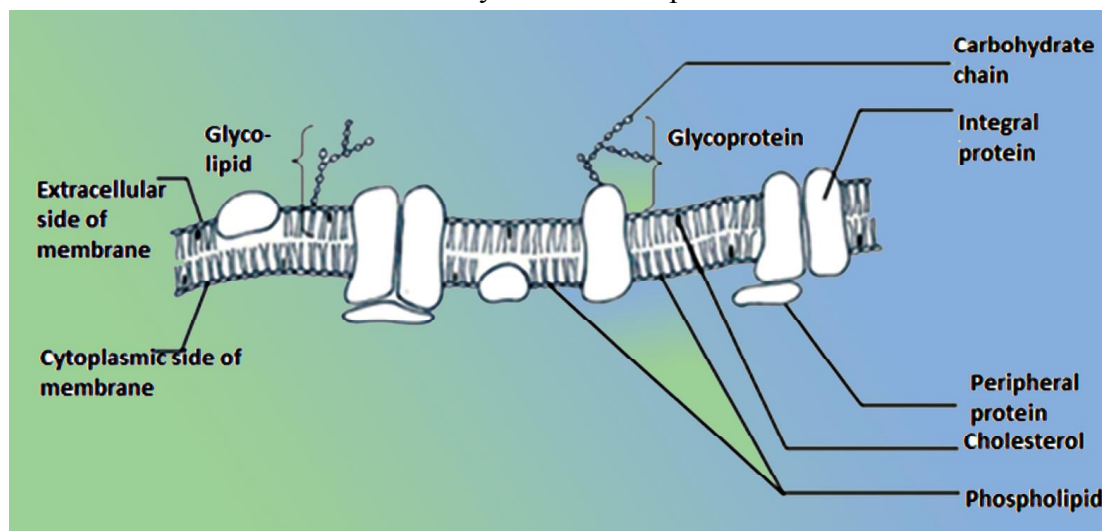
Some proteins are not embedded in the lipid bilayer at all, and are loosely bound to the inner surface of the membrane, called **peripheral proteins**.

Some proteins and lipids have short branching carbohydrate chains like antennae, forming **glycoprotein** and **glycolipids**, respectively.

Animal's cell membrane may contain few **cholesterol molecules** randomly integrated into the lipid bilayer.

These cholesterol molecules provide flexibility and stability to the membrane by reducing membrane fluidity at moderate temperatures and prevent membrane solidification at low temperatures.

The two sides of the membrane may differ in composition and function.



*Fig 2.20: Structure of the plasma membrane*

### Functions

- The plasma membrane surrounds the cytoplasm of living cell physically separating the intracellular components from the extracellular environment.
- Plasma membrane is selectively permeable and able to regulate the exchange of material needed for survival.
- Proteins embedded in the plasma membrane identify the cell, enabling nearby cells to communicate with each other (involved in cell recognition).
- Some protein molecules act as receptor molecules for interacting with specific biochemical, such as hormones, neurotransmitters and immune proteins.
- Some proteins in the cell membrane attach to some cytoskeletal fibers and help

to maintain the shape of the cell.

- Some proteins in the membrane act as enzymes. (e.g. Microvillus on epithelial cell lining of some parts of the gut contains digestive enzymes in their cell surface membrane.)

### **Subcellular components**

There are many sub-cellular components in the cell. Some of them are organelles, which are bound by membranes and suspended in the cytosol of eukaryotic cell to perform specialized functions.

### **Nucleus**

Most prominent organelle, consist most of the genes, having an average diameter of  $5\mu m$  and enclosed by a double membrane cover called nuclear envelope.

- Nuclear envelope- composed of two membranes, inner and outer membranes, separated by a space of 20-40 nm. Nuclear envelope is perforated by nuclear pores which has pore complex to regulate the entry and exit of substances. It has nuclear lamina, made up of protein filaments which line the interior side of the nuclear envelope.
- Nuclear matrix is made up of protein filaments and extended throughout the interior of the nucleus. Chromatin and nucleolus are embedded in the nuclear matrix.
- Nucleolus- appears as darkly stained granules with fibers adjoining part of the chromatin.
- Chromatin –appears as a diffused mass in electron micrographs of non dividing cells. It is a complex of DNA and proteins. During nuclear divisions, chromatin condenses, tightly coils and form threads, called chromosomes. Each species has a constant number of chromosomes. (e.g. typical human cell has 46 chromosomes).

### **Functions**

- Control all cellular activities.
- Synthesize DNA to produce new nuclei for cell divisions.
- Synthesize rRNAs and ribosomal subunits required for protein synthesis, through nucleolus.
- Synthesize mRNA and tRNA according to the information present on the DNA.
- Store and transport genetic information.

**Ribosomes**

These are subcellular components which carry out protein synthesis. They consist of two subunits; larger subunit and smaller subunit. They are composed of rRNA and protein. Ribosomes are found in two types; 70S and 80S. 70S ribosomes are found freely on the cytoplasm of prokaryotes, matrix of mitochondria and stroma of chloroplasts. 80S ribosomes are found only in eukaryotes. Based on the nature of presence, 80S ribosomes are categorized as two types; free ribosomes and bound ribosomes.

Free ribosomes: freely available as group in cytoplasm. Bound ribosomes are attached to the membrane surface of rough endoplasmic reticulum.

Functions

Protein synthesis

**Endoplasmic reticulum**

It is a network of internal membranes forming flattened or tubular sacs separating cytosol from ER lumen. It is continuous with the outer membrane of nuclear envelope. There are two types of ER; Rough ER and Smooth ER

**Rough ER**

Rough ER consists of flattened sacs, and ribosomes bound to surface. Proteins synthesized by ribosomes move into lumen of ER.

**Functions**

- Transport protein synthesized by ribosomes
- Synthesizing glycoproteins
- Produce transport vesicles
- Facilitate the growth of own membrane by adding phospholipids proteins and carbohydrates. Therefore called as membrane factory

**Smooth ER**

Smooth ER is a network of tubular sacs without ribosomes. Membrane bound enzymes are present.

**Functions**

- It synthesizes lipids including oils, steroids and phospholipids.
- Metabolism of carbohydrates.
- Produce transport vesicles to transport within cell.
- Involves in detoxification.
- Stores  $\text{Ca}^{2+}$  ions.

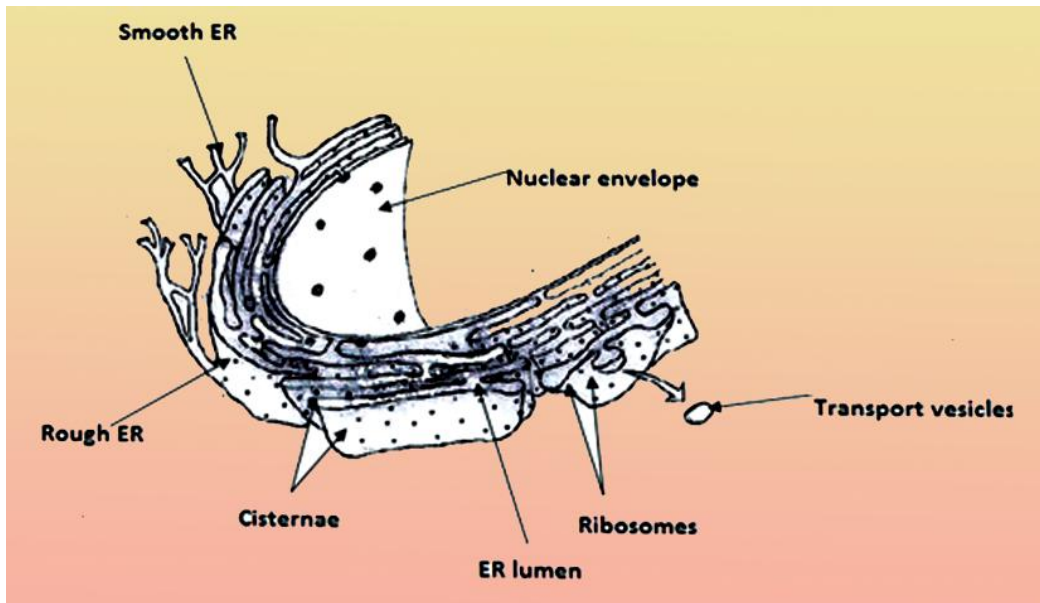


Fig 2.21: structure of the endoplasmic reticulum

### Golgi apparatus

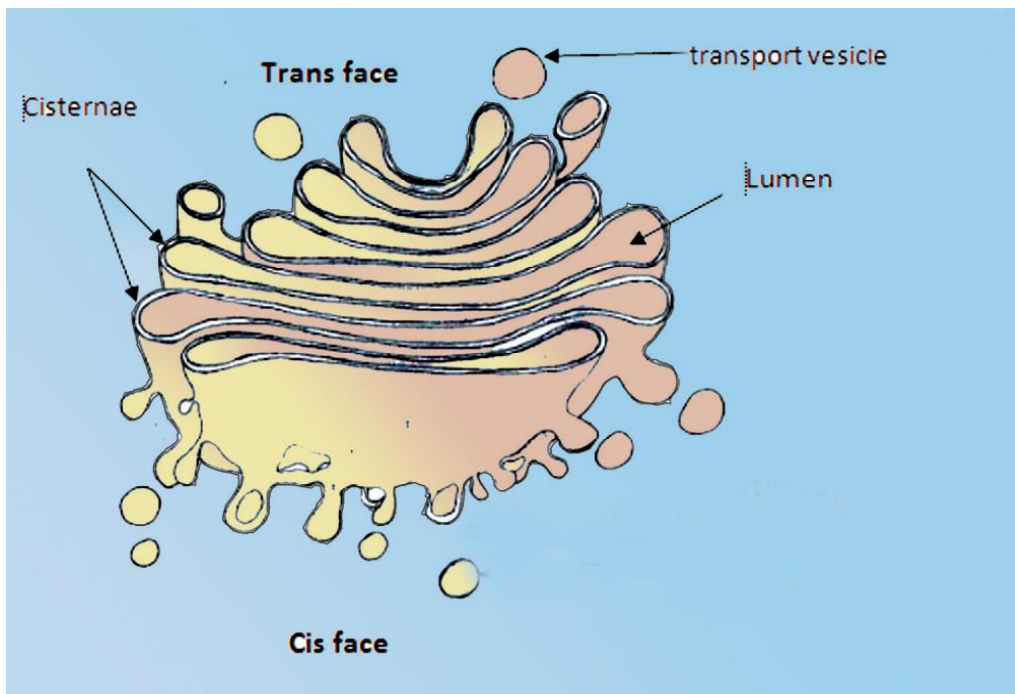


Fig 2.22: Structure of the golgi apparatus



Golgi apparatus is a stacks of flattened sacs or Cisternae. Inner and outer surfaces can be identified as cis face and transface respectively. Cis face is located near the E.R to receive vessicles from E.R. Trans face give rise to secretory vessicles which budded off and travel other side. Golgi complex is abundant in secretory cells.

**Functions**

- Collecting, packaging and distribution of materials
- Manufacturing cellulose and non cellulose cell wall components such as pectin
- Produce lysosomes

**Lysosomes**

They are single membrane bounded vesicles contributing to digestive activity. They contain hydrolytic enzymes which catalyze breakdown of carbohydrates, proteins, lipids and nucleic acids.

**Functions**

- Digest food particles received by phagocytosis
- Transport residue material out of cell by exocytosis.
- Digest worn out organelles
- Autolysis causing cell death.

**Peroxisome**

They are single membrane bounded vesicles with oxidizing enzymes. They are present in both plants and animals. Enzymes in peroxysome catalyze the breakdown of  $H_2O_2$ .

**Functions**

- Detoxification of peroxides
- Photorespiration in plants

Specialized peroxysomes called glyoxysomes are found in fat storing tissues in plants. Glyoxysomes converts fatty acids into sugar.

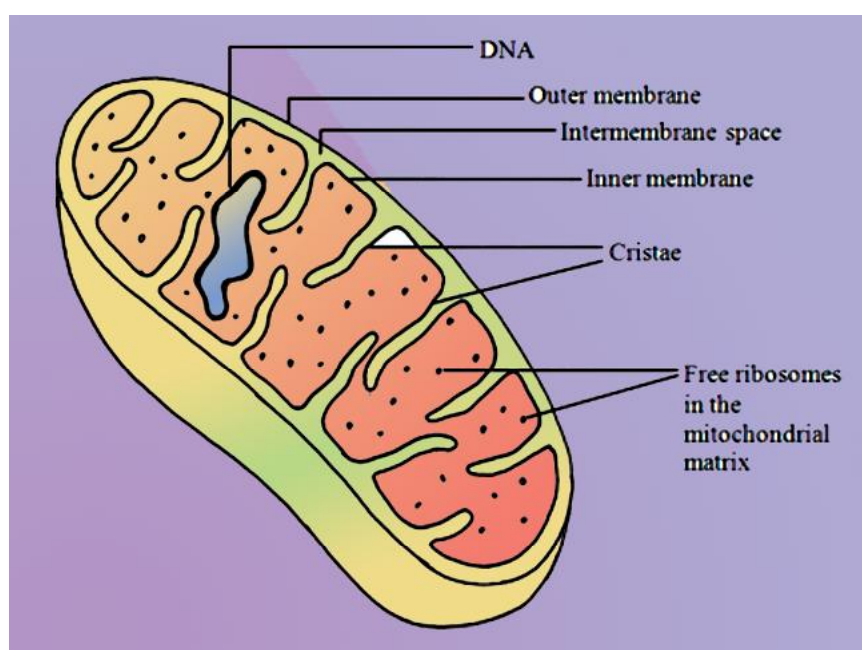
**Mitochondria**

It is one of the most common organelles in eukaryotic cells. It is an elongated organelle with two enclosing membranes. Outer membrane is smooth but the inner membrane is convoluted to form cristae. Cristae increase the surface area and they contain stalk particles. The gap/space in between inner and outer membranes of the mitochondrion is called intermembrane space. The inner most part of the organelle is known as mitochondrial matrix, which consists of 70 s ribosomes circular DNA

molecule (mitochondrial DNA), phosphate granules and enzymes. The matrix carries enzymes for the reactions in Krebs cycle (in cellular respiration). Further, cristae composed of proteins and enzymes essential for electron transport chain and oxidative phosphorylation.

### Functions

- Synthesize ATP in aerobic respiration
- Involve in Photorespiration



*Fig 2.23: Structure of the mitochondria*

### Chloroplast

It is a biconvex lens shaped organelle with two membranes which is found in plants and some protists. The outer and inner membranes are smooth and are separated by a very narrow intermembrane space. Inside the chloroplast there is another membrane system. This membrane produces flattened and interconnected sacks called thylakoids. Thylakoids contain complexes called photosystems which are made up of photosynthetic pigments. Thylakoids stacked to form a granum. The grana are interconnected by inter granal lamellae. The fluid outside the thylakoid is stroma which contain circular DNA (chloroplast DNA), 70s ribosomes, many enzymes, starch granules and lipid droplets.

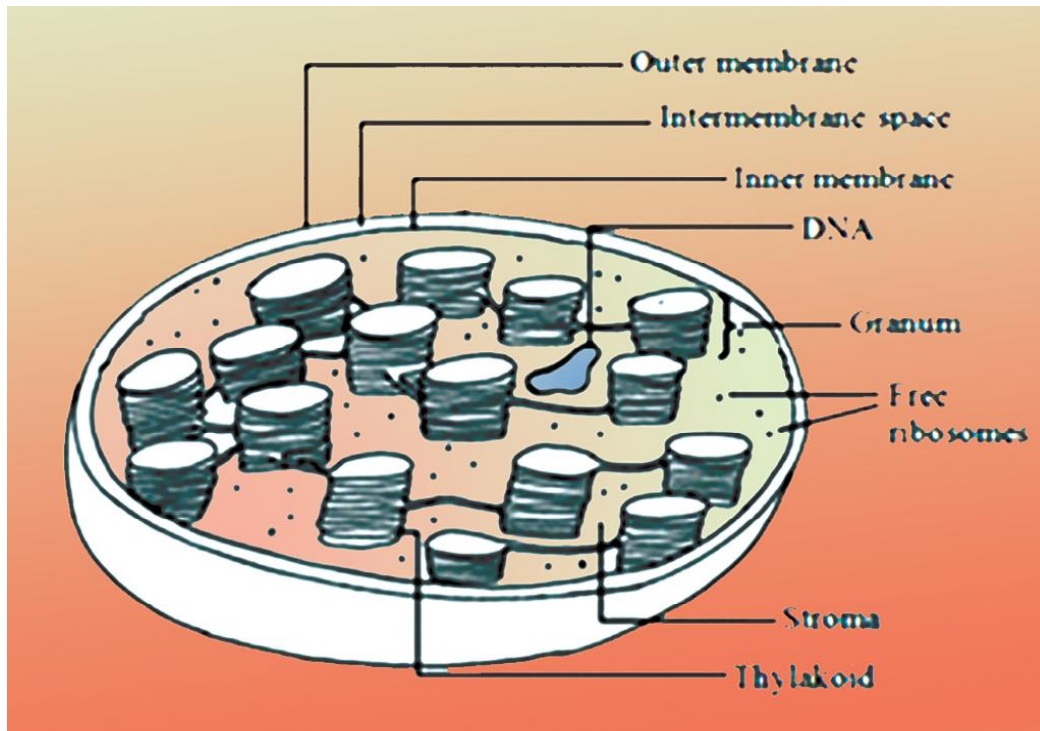


Fig 2.24: Structure of the chloroplast

### Functions

- Photosynthesis

### Cytoskeleton

Cytoskeleton is the supporting structure of the cell and maintains its shape. It is more important for animal cells which lack cell walls. Cytoskeleton is made out of microtubules and protein filaments. Additionally, it is Dynamic hence, has the ability to break and reform as needed.

There are three types of components in the Cytoskeleton as follows;

- Microtubules
- Actin filaments or Microfilaments,
- Intermediate filaments

**Table 2.5: Differences between Microtubules, Microfilaments and intermediate filaments**

<b>Property</b>	<b>Microtubules (Tubulin polymers)</b>	<b>Microfilaments (Actin filaments)</b>	<b>Intermediate filaments</b>
Structure	Hollow tubes; wall consists of 13 columns of tubulin molecules	Two intertwined strands of actin, each strand is a polymer of actin subunits	Fibrous proteins supercoiled into thicker cables
Protein subunits	Tubulin	Actin	One of several different proteins (e.g. Keratin), depending on the cell type.
Main functions	Maintenance of cell shape Cell motility (as in cilia or flagella) Chromosome movements in cell division Organelle movements	Maintenance of cell shape (tension-bearing elements) Changes in cell shape Muscle contraction Cytoplasmic streaming in plant cells Cell motility (as in pseudopodia) Cell division in animal cells (cleavage furrow formation)	Maintaining of cell shape (tension-bearing elements) Anchorage of nucleus and certain other organelles. Formation of nuclear lamina

**Functions**

- Provide strength to the cytoplasm
- Anchorage organelles and cytosolic enzymes of the cell
- Movement of cytoplasm, cytoplasmic streaming, positioned organelles and move chromosomes when necessary.
- Maintain the shape of the cell (mainly in animal cells)

## Cilia and Flagella

Cilia and flagella share a common structure. Flagella are long elongated structures and Cilia are short cellular projections that are often organized in rows. Cilia are more numerous than flagella on the cell surface. They are made of microtubules, with a 9+2 structure (Nine doublets of microtubules are arranged in a ring, with two single microtubules in its center). They are covered by plasma membrane and bound to a basal body which anchors the cilium or flagellum to the cell. The Basal body has 9 + 0 arrangement (no microtubules in its center)

## Functions

- Act as locomotor appendages
- Can move fluid over the surface of the tissue
- Cilia lining in oviducts help move an egg toward the uterus

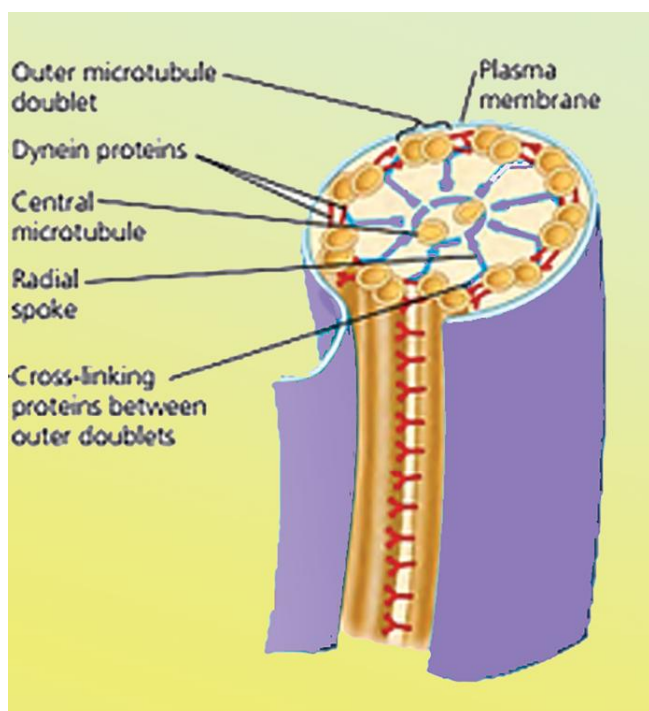


Fig 2.25: Structure of the Cilium

## Centrioles

Centriole is made up of cylindrically arranged microtubules which are non membrane bounded subcellular component present only in animal cells. Each centriole composed of nine sets of triplet microtubules arranged in a ring (9+0). A pair of centrioles which arranged perpendicular to each other are located in a region called centrosome near the nucleus.

## Functions

- Produce aster and spindle in cell division

### Central Vacuole

Central vacuole is a large structure, bound by tonoplast, filled with liquid called cell sap found in plant cells. The composition of sap differs from cytosol and it contains water, ions such as Potassium and Chloride and sometimes water soluble colored pigments such as anthocyanin.

### Functions

- Stores water and other materials such as sugars, ions and pigments.
- Maintains water balance of the cell
- Gives turgidity and support to cell.
- Produce colours in some plants with sap pigments
- Stores soluble substances needed for cellular activities.

### Extracellular components

#### 1. Cell wall

Cell wall is an extracellular structure of plant cells. Animal cells do not have cell walls. However, prokaryotes, fungi and some protists also have a thin and flexible cell wall. The chemical composition of the wall greatly varies from species to species and even from one cell type to another even in the same plant. Nevertheless in Plants, cell wall is generally made up of cellulose, pectin, hemicellulose, lignin and suberin (in some plant cells only).

Plants generate two types of cell walls: primary and secondary walls. Young cells first secrete primary cell wall: it is the wall laid down during plant cell division.

Just outside the primary wall there is a thin layer (middle lamella) which is rich in sticky polysaccharides called pectins (magnesium and calcium pectate). Middle lamella glues adjacent cells together. Due to the deposition of hardening substances on the primary wall a secondary cell wall is generated secondarily.

Primary cell wall is permeable, relatively thin, flexible, composed mainly of cellulose fibers which are laid unevenly running through the extracellular matrix (middle lamella) Water can move freely through the free spaces of cell wall

Secondary cell wall lies between plasma membrane and primary cell wall. It contains several layers of hard materials, forming a rigid structure. In addition to cellulose, impermeable substances such as lignin and suberine are also incorporated in to the secondary wall. Lignin cement anchors cellulose fibers together providing hard and rigid matrix, giving the cell wall an extra support.

Cell wall has pits through which cytoplasm of adjoining cells join through plasmodesmata.

### Functions

- Protection and support
- Allows development of turgidity when water enters the cell
- Prevents bursting during turgidity
- Limits and control cell growth
- Component of appoplast pathway
- Maintaining cell shape
- hold the plant up against the force of gravity

## 2. Cell junctions

Cell junctions are structures at which neighbouring plasma membranes are joined. They are also interact and communicate via sites of direct physical contacts.

### Functions

- Connects the internal chemical environment of adjacent cells.
- Cell junctions are structures at which cytoplasm of adjoining cells are joined. There are three types of cell junctions in animal cells
- Tight junctions – connect the plasma membranes of adjacent cells tightly bound by specific proteins forming continuous seals around the cells. Prevent leakages of extracellular fluids through intercellular space. e.g. skin epithelium
- Desmosomes/Anchor junctions – mechanically attach the cytoskeletons of adjoining cells by intermediate filaments for strong binding.e.g. muscle tissue
- Gap junctions /Communicating junctions – provide cytoplasmic channels from one cell to an adjacent cell. Gap junctions consists of special membrane proteins that surround the pore through which ions, sugars amino acids may pass. They allow signal and material exchange between adjacent cells through direct connections. e.g.heart muscles, animal embryo.

### Plasmodesmata

- Microscopic channels which runs through plant cell walls. They are cytoplasmic living connections between cytoplasm of adjoining cells. These are membrane lined channels filled with cytoplasm.

### Extracellular matrix of animal cells

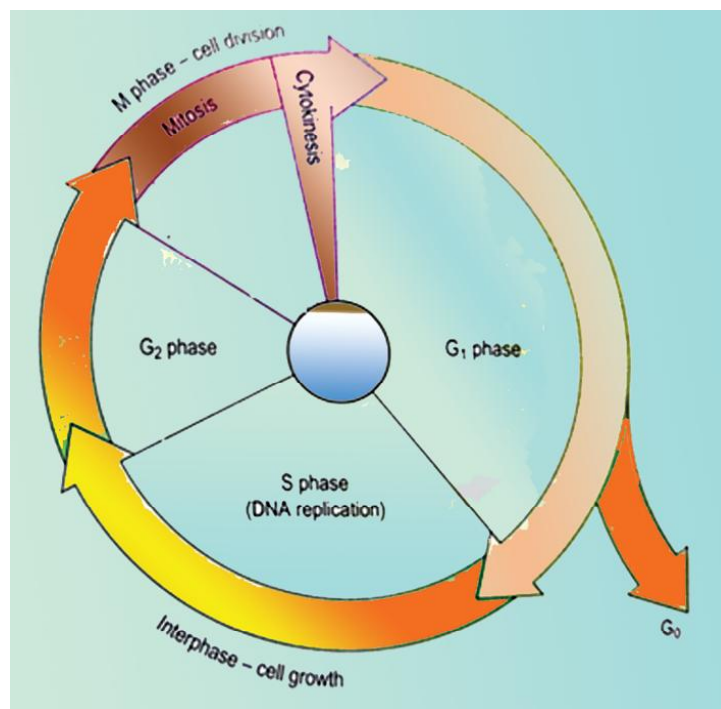
Although animal cells lack cell walls they do have elaborate extracellular matrix (ECM). Main components of the ECM are glycoproteins and other carbohydrates containing molecules secreted by the cells. Most abundant glycoprotein in the ECM of most animal cell is collagen which forms strong fibres outside the cell. The collagen fibres are embedded in a network woven out of proteoglycan secreted by cells.

Functions

- Forms a protective layer over the cell surface
- Linking extra cellular matrix and cytoskeleton.
- Influences the cell behavior by Involving in the mechanical and chemical signaling.

### The cell cycle and the process of cell division

The sequence of events that takes place in the cell from the end of one cell division to the end of the next cell division is referred to as cell cycle. At the end of the cell division, two genetically identical daughter cells resembling the parent cell are produced in mitosis.



*Fig 2.26: The cell cycle*



## Eukaryotic cell cycle

### Mitosis

Eukaryotic cell cycle may be divided into two major phases.

- Interphase
- Mitotic phase/ M-phase

Interphase is the longer phase of cell division. It covers about 90% of the cell cycle. Interphase could be divided into three phases;

- G<sub>1</sub> phase (first gap phase)
- S phase (synthetic phase)
- G<sub>2</sub> phase (second gap phase)

### G<sub>1</sub> phase

In this phase synthesis of proteins and production of cellular organelles leading to cell growth occur. Proteins essential for S phase are produced during this phase.

### S phase

DNA replication occurs and synthesis of histone proteins takes place. DNA winds around histone beads and forms chromatin.

### G<sub>2</sub> phase

Cells continue to grow through protein synthesis as well as cellular organelles. Proteins essential for mitotic phase will be synthesized. Duplication of centrosomes takes place.

There are cell cycle-controlling checkpoints available at G<sub>1</sub>, G<sub>2</sub> and M phases to ensure that the cell is ready for moving into upcoming phases of cell division. Some cells receive a go-ahead signal at the G<sub>1</sub> check point, it will usually complete the G<sub>1</sub>, S, G<sub>2</sub> and M phases and divide. If it does not receive a go-ahead signal at that point it may exit the cycle, entering into a non-dividing stage called the G<sub>0</sub> phase. The most cells of the human body are actually in the G<sub>0</sub> phase. e.g. nerve cells and muscle cells.

### Mitotic phase/ M phase

M phase covers only about 10% of cell cycle. This includes mitosis and cytokinesis.

### Mitosis

Mitosis is referred to the nuclear division which gives rise to two genetically identical daughter nuclei from a mother nucleus. This may be divided into five stages; prophase, prometaphase, metaphase, anaphase and telophase in order to ease the learning of activities of cell cycle.

### **1. Prophase**

Chromatin fibers get condensed by shortening and thickening and transformed into chromosomes. As a result chromosomes will be visible through light microscope. Nucleoli get disappeared and chromosomes appear with two sister chromatids attached at the centromere. Chromosomal arms of sister chromatids attached by special proteins called cohesion. The formation of mitotic spindles begins. Spindle includes the centrosomes, the spindle microtubules and the aster.

Centrosomes move toward opposite poles of the cell due to the lengthening of microtubules between them.

### **2. Prometaphase**

The nuclear envelope fragments. Chromosomes get even more condensed. A special protein called kinetochore attaches the sister chromatids of each chromosome at their centromere. Some of the microtubules that attach to the kinetochore of the chromosomes move the chromosomes back and forth. Microtubules which are not attached to the kinetochore interact with those from the opposite poles.

### **3. Metaphase**

Centrosomes reach the opposite poles. The chromosomes have arrived to a place called metaphase plate which is located in equal distance from each pole. The centromeres of all chromosomes are located in the metaphase plate. At the end of this phase, each chromosome of the cell get attached to the kinetochore microtubule at their centromere and aligned at the metaphase plate.

### **4. Anaphase**

Sister chromatids are separated at the centromere. Microtubules attached to kinetochore get shorten and pull sister chromatids towards the opposite poles. Cell elongates as the non kinetochore microtubules are lengthen. By the end of anaphase equal and complete set of chromosomes found at each pole of the cell.

### **5. Telophase**

Nuclear envelope reforms around each set of chromosomes at opposite poles. Nucleoli reappears. Spindle microtubules get depolymerized. Chromosomes unwind and become less condense to form chromatin. Two genetically identical daughter nuclei are formed.

### **Cytokinesis**

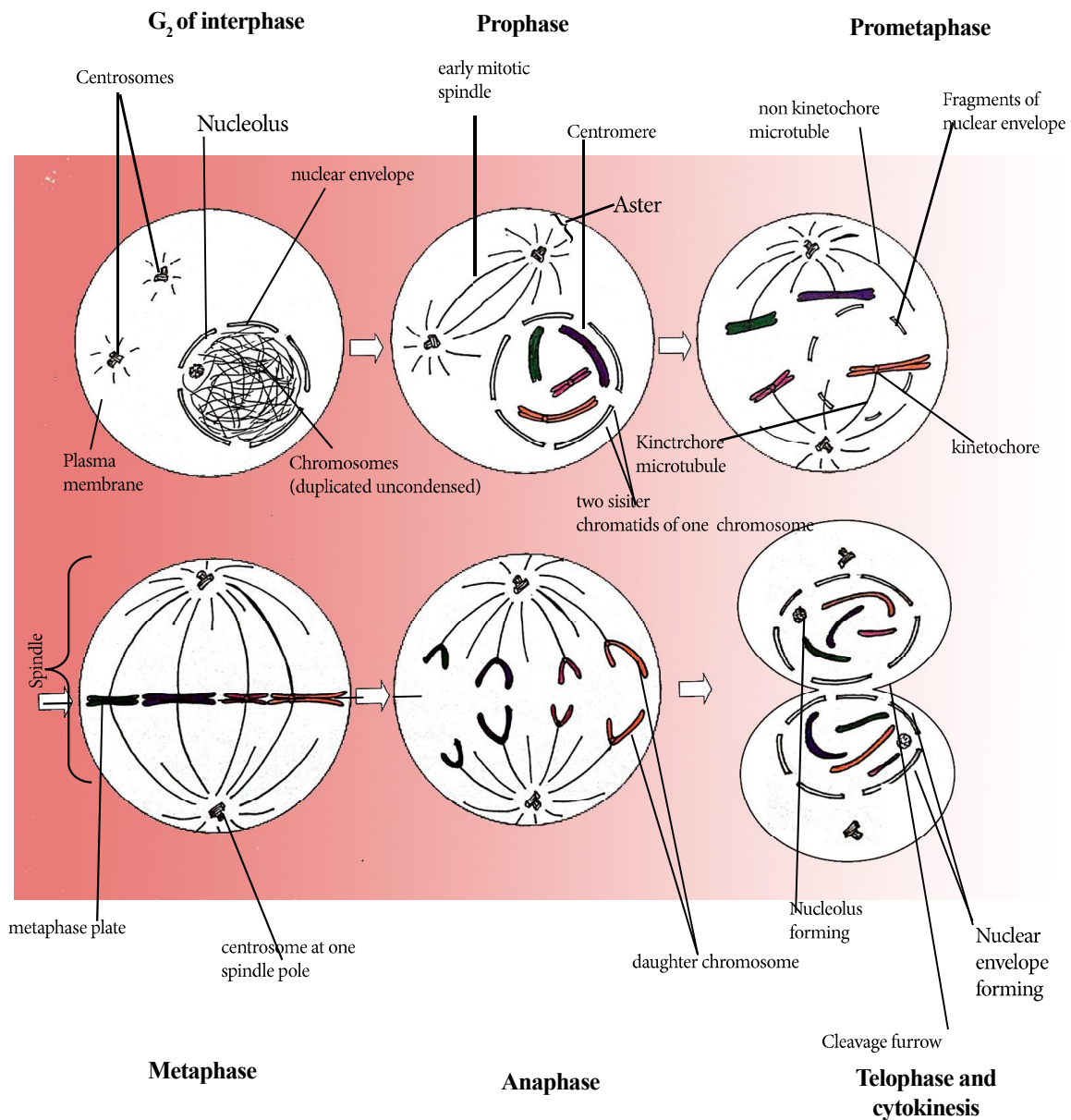
The division of the cytoplasm starts at the end of the telophase. Therefore at the end of the mitosis two genetically identical daughter cells are produced.

In animal cells- a cleavage furrow forms. This produces two genetically identical daughter cells.

In plant cells- cell plate forms as a result of vesicle produced by golgi apparatus. This divides the cytoplasm in to two and generates two genetically identical daughter cells to the parent cell.

**Significances of mitosis**

1. Maintains the genetic stability
2. Growth and development
3. Cell repair, replacement and regeneration
4. Asexual reproduction



*Fig 2.27 : The phases of mitotic cell cycle*

## Meiosis

Sexually reproducing organisms undergo different type of cell division called meiosis.

Meiosis

Meiosis is a type of nuclear division which gives rise to four haploid, genetically non identical daughter nuclei, from a diploid mother nucleus.

Meiosis involves two consecutive nuclear divisions, Meiosis I and Meiosis II.

Meiosis I is a reduction division and Meiosis II is similar to mitosis, each stage consists of four sub-phases: prophase, metaphase, anaphase, and telophase.

Before meiosis one cell is in interphase, during S phase of the interphase DNA replication occur.

### Meiosis I

#### 1. Prophase I

Cell enters to the prophase from interphase. Chromosomes begin to condense. Nucleolus begins to disappear. Next the formation of zipper like structure called the synaptonemal complex by a specific proteins holds two homolog tightly together. The pairing and physical connection of homologous chromosomes is called synapsis.

During synapsis part of the DNA molecule of non-sister chromatids paired homologous chromosomes break, exchange and rejoin at corresponding point. This process is called crossing over. These points of crossing over become visible as chiasmata after the synaptonemal complex disassembles and the homologous chromosomes slightly apart from each other

Nuclear envelope breaks. Centrosomes move towards opposite poles forming spindle in animal cells.

The kinetochore of each homologue attach to microtubule from one pole or the other. The homologous pair then moves toward the metaphase plate.

#### 2. Metaphase I

The pair of homologous chromosomes get arranged on the metaphase plate with one chromosome of each pair faces each pole. Both chromatids of a homologue are attached to kinetochore microtubules from one pole and those of the other homolog are attached to kinetochore microtubules from the opposite pole. Homologous chromosome arrange randomly at metaphase plate.

### 3. Anaphase I

Kinetochores of microtubules of the spindle get shorten. Homologous pair separates and one chromosome of each pair moves towards the opposite pole. Sister chromatids of each chromosome remain attached at the centromere and move as a single unit towards the same pole.

### 4. Telophase I

One complete haploid set of chromosomes accumulate at each pole. Nuclear envelope reforms around each set of chromosomes. Nucleoli reappear. Spindle disintegrates. Chromosomes decondensed into chromatin. Genetically non identical, haploid, two daughter nuclei are formed within one cell.

### Cytokinesis

Usually occurs simultaneously with telophase I. Genetically non identical, haploid, two daughter cells are formed. In animal cells, cleavage furrow is formed. In plant cells a cell plate is formed.

No DNA replication occurs between meiosis I and meiosis II

## Meiosis II

### 1. Prophase II

Centrosomes start producing spindle apparatus (spindle fibers, aster centrosome). Chromatin fibers condense and produce chromosomes with two sister chromatids. Nuclear envelope breaks down into fragments. Nucleolus disappears. During the late prophase II centromere of the chromosomes are moved to the metaphase II plate.

### 2. Metaphase II

All Chromosomes get attached to the microtubules at their centromere and aligned on the metaphase plate. Kinetochores of sister chromatids are attached to microtubules extending from both poles.

Due to the crossing over in meiosis I, the two sister chromatids of each chromosome are not genetically identical.

Meiosis II usually takes place in the perpendicular direction of Meiosis I. Therefore, metaphase plate of meiosis II is perpendicular to the metaphase plate of meiosis I.

### 3. Anaphase II

Due to the breakdown of proteins attaching sister chromatids, they are separated at centromere. As a result of shortening of microtubules, sister chromatids of each chromosome move towards opposite poles.

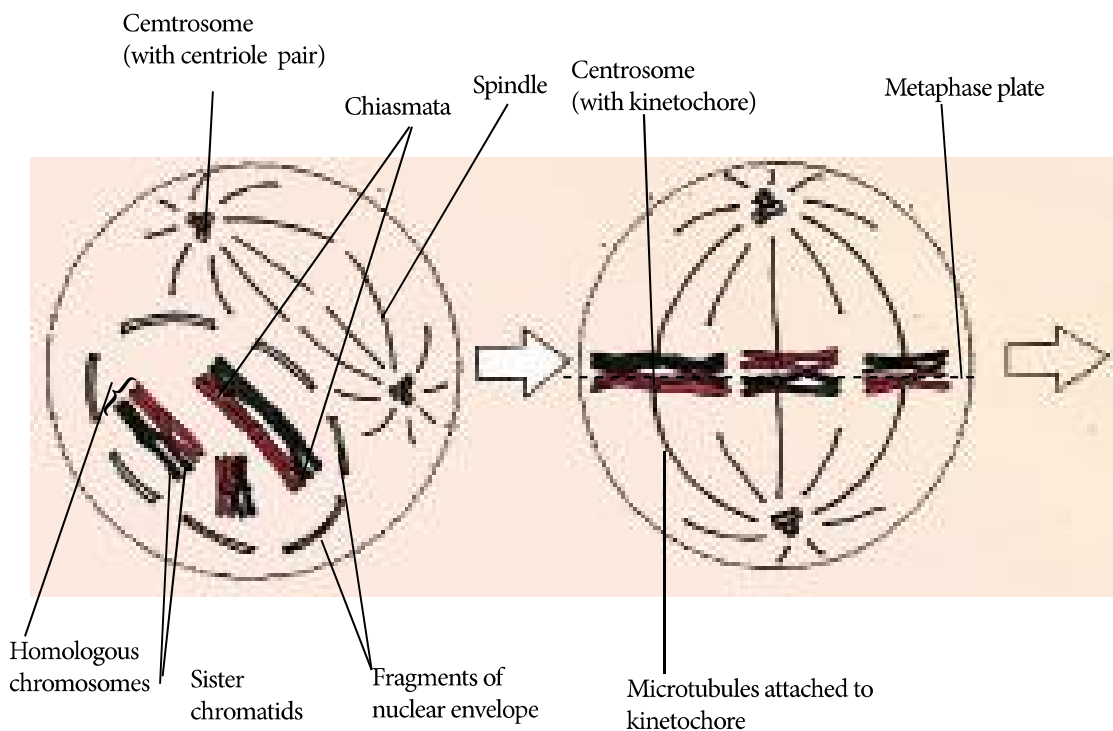
#### 4. Telophase II

Nuclear envelope and nucleolus reform. Chromosomes decondense into chromatin. Spindle disassembles. Genetically non identical, haploid, four daughter nuclei are formed from one parent cell.

#### Cytokinesis

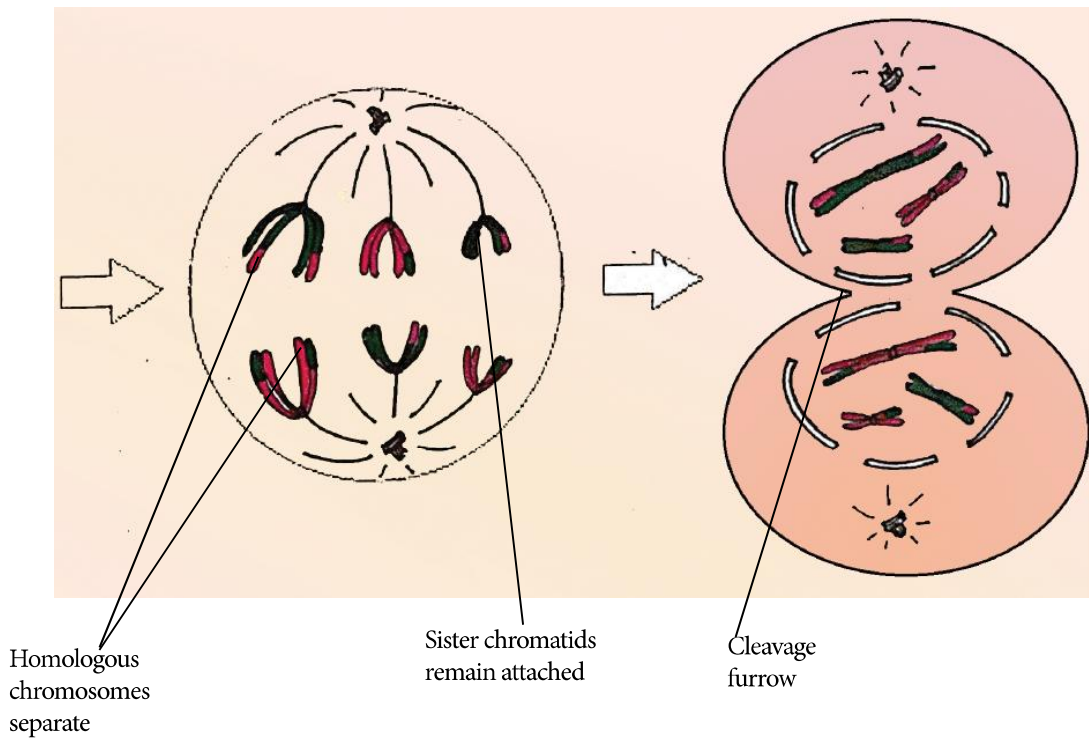
Cytokinesis occurs as in mitosis. Genetically non identical, haploid, four daughter cells are formed. These four daughter cells are not even identical to their parent cell.

Centrosomes or centrioles are not available in plant cells. However, spindle is formed during cell division from accumulated microtubule complex.



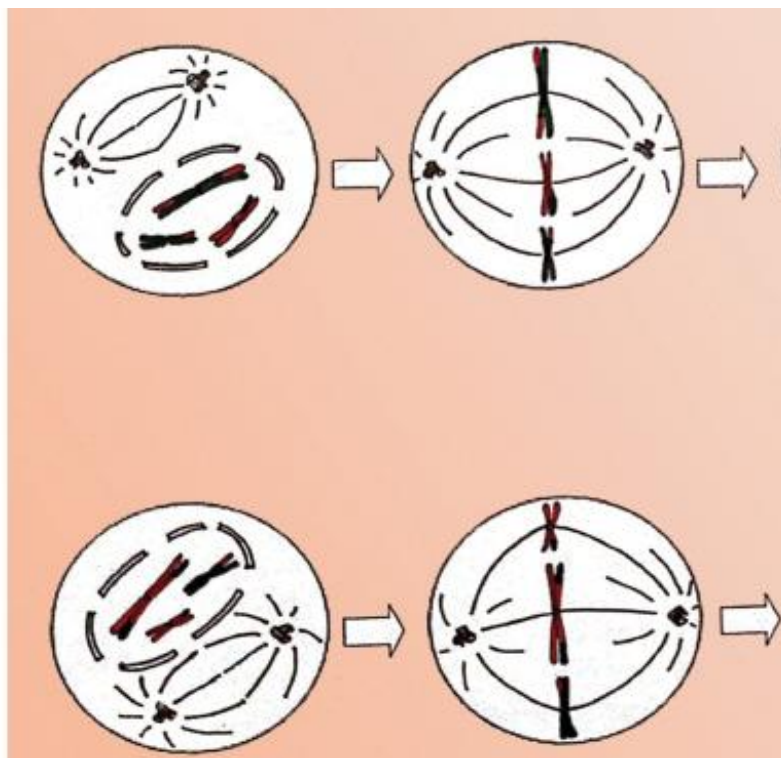
**Meiosis I  
Prophase I**

**Meiosis I  
Metaphase I**



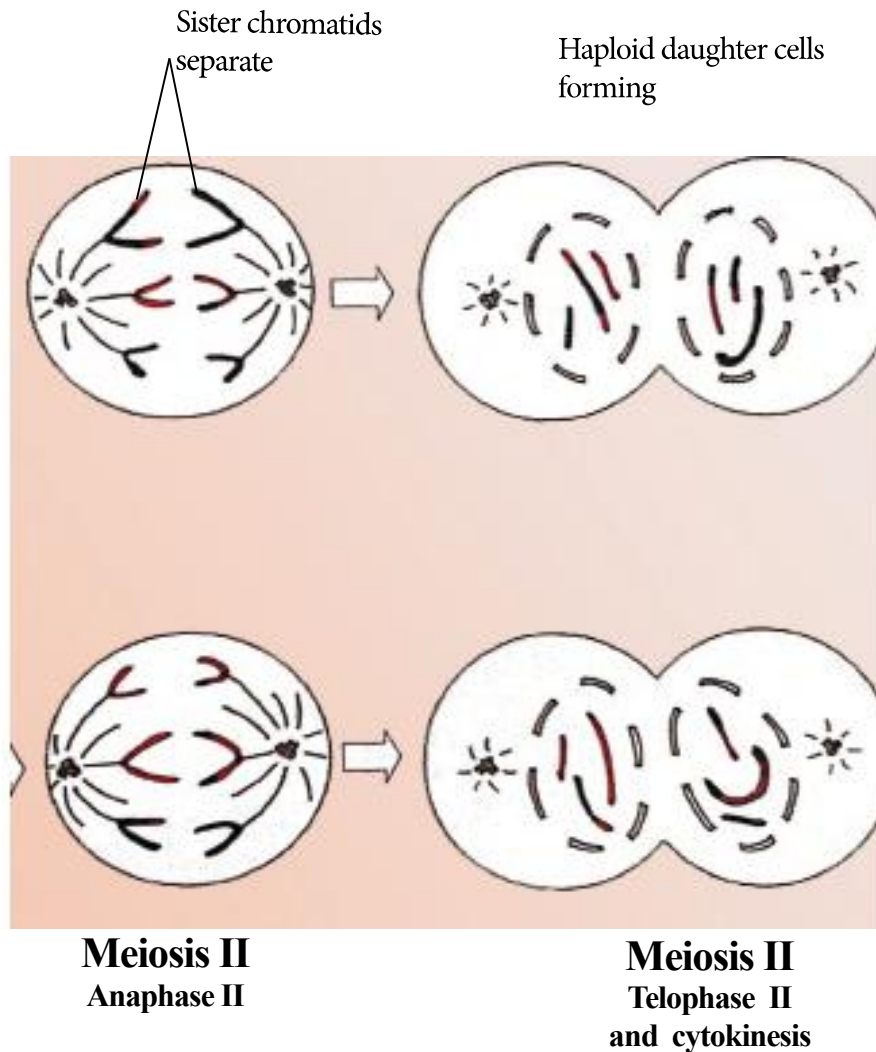
**Meiosis I**  
**Anaphase I**

**Meiosis I**  
**Telophase I**  
**and cytokinesis**



**Meiosis II**  
**Prophase II**

**Meiosis II**  
**Metaphase II**



*Fig 2.28: The phases of meiosis*

### Significance of meiosis

- Maintains the constant number of chromosomes through generations in sexually reproducing species.
- Produce new genetic variations leading to evolution.
- Genetic variation occurs due to crossing over, recombination and independent assortment.

### Tumor, cancer and galls

- Cell division is driven by external and internal factors. They may be chemical or physical factors
- Cancer cells do not respond normally to the body's control mechanism
- They divide excessively and invade other tissues. If unchecked they can kill the organism.



- Cancer cells do not consider the normal signals that regulate the cell cycle.
- They do not need growth factors. They may make required growth factors themselves or giving signals to continue cell cycle without growth factors. Another possibly is an abnormal cell cycle control system.
- The problem begins when a single cell in a tissue undergoes transformation, the process converts a normal cell to abnormal cell.
- If the body immune system can not recognize and destroy it, it may leads to proliferation of cells and formation of a tumor.
- If the abnormal cells remain at the original site, the lump is called benign tumor. Most benign tumors do not cause serious problems and can be completely removed by a surgery.
- A malignant tumor becomes invasive and attack one or more organs. An individual with a malignant tumor is said to have a cancer.
- A few tumor cells may separate from the original tumor, enter blood vessels or lymph vessels and travel to other parts of the body. They may proliferate and form a new tumor.
- This spread of cancer cells to locations distant from their original site is called metastasis.

### **Galls in plants**

- This occurs due to uncontrolled mitotic division of plant cell.
- The plant cell division is controlled by maintaining a proper balance between plant growth regulators such as auxins and cytokinins. When this balance is lost plant cells produce undifferentiated mass of cells.
- Galls are the bumps and growths that develop on different parts of plants after being invaded by some very unique organisms.
- Galls have range of causes, including viruses, fungi, bacteria, insects and mites.
- Usually the gall causers in some way attack or penetrate the plants growing tissues and causes the host to reorganize its cells and to develop an abnormal growth.

### **The energy relationships in metabolic processes**

Sum of all biochemical reactions of living being is known as the metabolism and it consists of all catabolic and anabolic reactions.

Catabolism is breaking down of complex molecules into simple molecules by releasing free energy. Therefore it is an exergonic reaction. Anabolism is making complex molecules from the simple molecules by absorbing free energy. Hence it is an endergonic reaction.

Biochemical reactions involved in usage of energy released by catabolic reactions in

living system are called as anabolic reactions. ATP acts as the energy carrier in all living organism including the simplest bacteria. Therefore the ATP is known as the universal currency of energy transactions.

Energy can be defined as the capacity to do work. All living organisms require energy for their living process in many ways. Such processes are;

- Synthesis of substances
- Active transport across plasma membrane
- Transmission of nerve impulses
- Muscle contraction
- Beating of cilia and flagella
- Bioluminescence
- Electrical discharges.

Overall idea of the energy relations of living system on biosphere is composed of following steps.

- Energy flows into biological systems from the environment through solar radiation. (Primary energy source is the Sun)
- Light energy is captured in the cells having photosynthetic pigments (chlorophyll) by the process of photosynthesis and stored as chemical energy in the organic compounds such as carbohydrates
- Captured energy in organic food is transformed into chemical energy in ATP by a process called cellular respiration.
- The energy stored in ATP is utilized in various energy requiring processes.

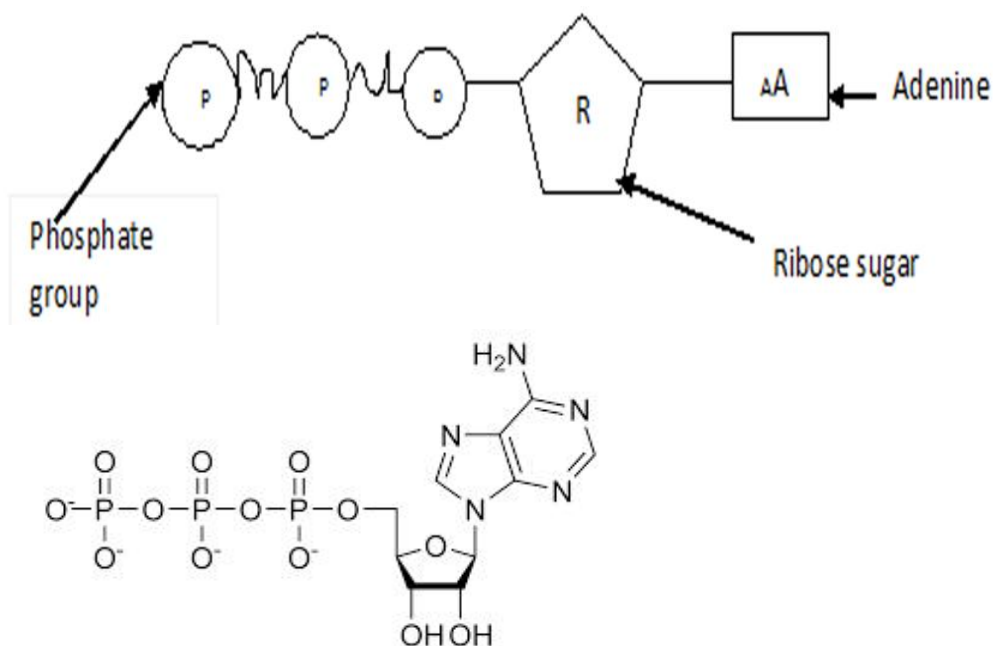
### **ATP (Adenosine Tri Phosphate)**

ATP is a nucleotide, consisting of,

- Ribose- sugar
- Adenine - nitrogenous base
- A chain of three phosphate groups.

During the hydrolysis of ATP, ADP and Pi are produced. As a result, a very high energy is released. This is because the reactants (ATP and water) contain more energy in comparison to products (ADP and Pi). Therefore it yields energy and is an exergonic reaction.

When ATP is hydrolyzed, the free energy yield of each of the two end phosphate groups is  $-30.5\text{kJ/mol}$ .



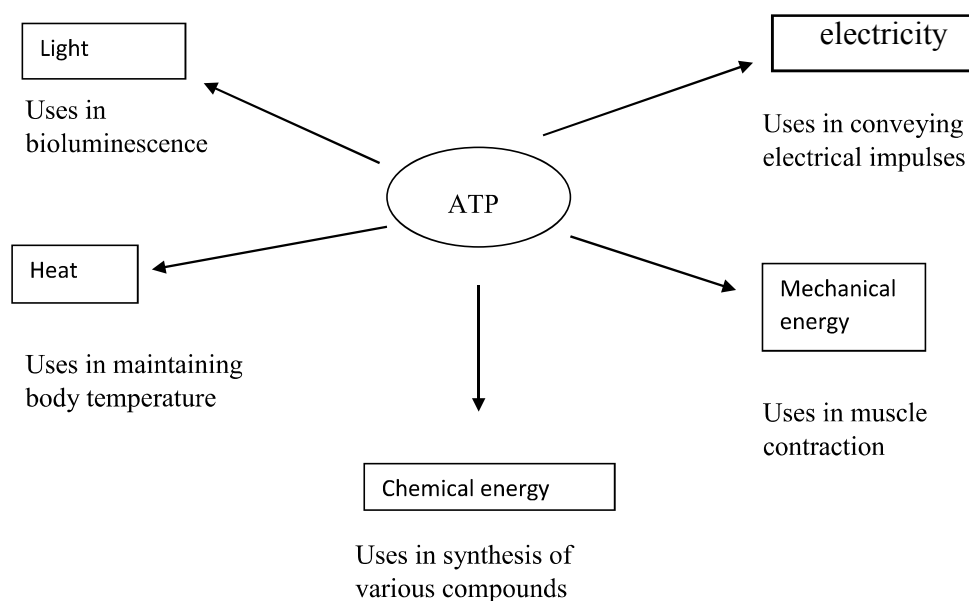
**Fig 2.29: Chemical structure of ATP molecule (need not be memorized)**

Most biological reactions use the energy released during breaking of the terminal phosphate bond. ATP is mobile. Therefore it can carry energy to anywhere in the cell, for any energy consuming reaction.

ATP can be produced within living cells within a short period of time, using ADP, inorganic phosphate (Pi) and energy. Production of ATP within cells is called phosphorylation. According to the energy source phosphorylation is divided as;

- |                                |  |                           |
|--------------------------------|--|---------------------------|
| i. Photophosphorylation        | – synthesis of ATP using solar energy in photosynthesis  | } In cellular respiration |
| ii. Substrate phosphorylation  | – synthesis of ATP using energy released by the breaking down of complex molecules into simple ones. |                           |
| iii. Oxidative phosphorylation | – synthesis of ATP using energy released as a result of oxidation of molecules.                      |                           |

In living cells energy in ATP is transformed in to various energy forms which are used for different functions.



### The role of Enzymes in regulating metabolic reactions

An enzyme is a macromolecule, which acts as a biological catalyst. Enzymes are produced in living cells/

General characteristics of an enzyme:

1. Most of the enzymes are globular proteins.
2. Enzymes are biological catalysts. They lower the activation energy of the reaction they catalyze (increases the rate of reaction).
3. Most enzymes are heat liable/ sensitive
4. Their presence does not alter the nature or properties of the end products of any reaction.
5. Enzymes are highly specific to the substrate (substrate specific)
6. Most enzyme catalyzed reactions are reversible.
7. The rate of enzyme activity is affected by pH, temperature and substrate concentrations.
8. They are not being used up during the reaction.
9. Enzymes possess active sites where the reaction takes place.
10. Some enzymes need non-proteinous components to catalyse the reaction which are known as cofactors.

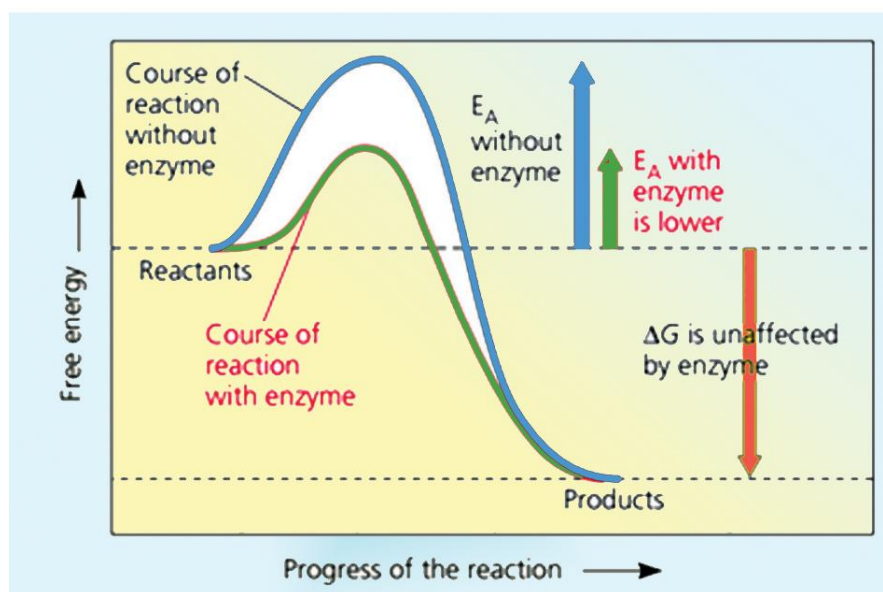
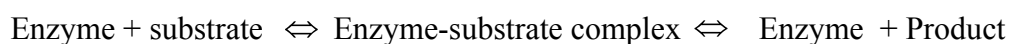


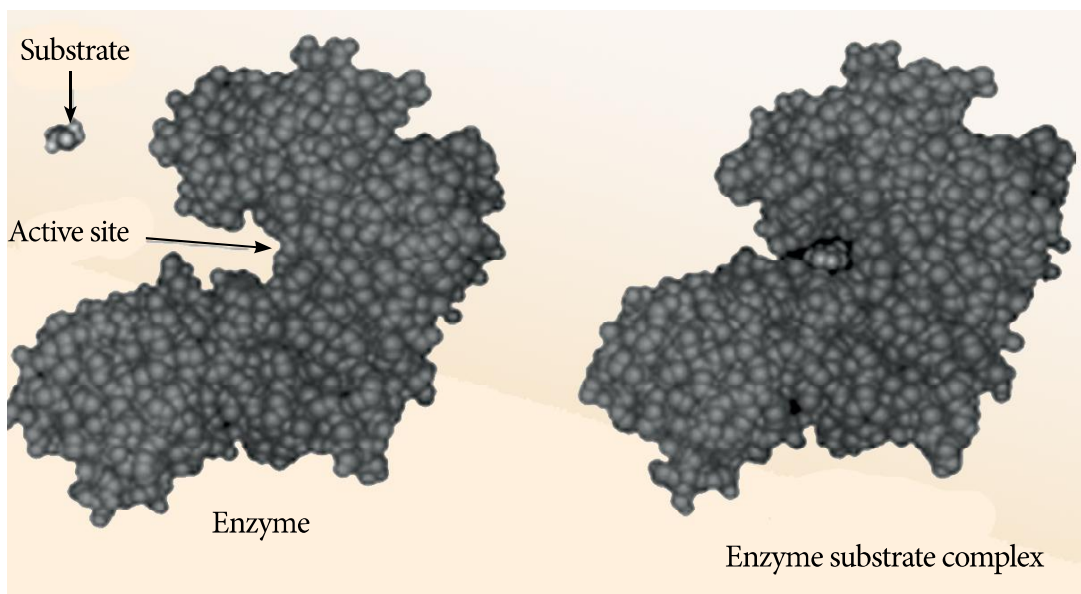
Fig 2.30 - The relationship between activation energy and the enzyme

### The mechanisms of enzyme action

The reactant and enzyme acts on is referred to as the substrate. The enzyme binds to its substrate forming enzyme-substrate complex. While enzyme and substrate form their complex, catalytic action of the enzyme converts the substrate to the product.



The reaction catalyzed by each enzyme is very specific. The specificity of an enzyme results from its shape. The substrate binds to a specific region of the enzyme. This region is called the active site. The active site is formed by only a few amino acids. Other amino acids are needed to maintain the shape of the enzyme molecule. The shape of the active site is complementary to the shape of the specific substrate of the enzyme, and hence important in the substrate specificity of the enzyme. The shape of the active site of an enzyme is not always fully complementary to its substrate. As enzymes are not rigid structures, the interactions between substrate and active site may slightly change the shape of the active site, so that the substrate and the active site become complementary to each other. This is called induced fit mechanism. The tight fit not only brings the substrate molecules and the active site close to each other, but also ensures the correct orientation of the molecules to help the reaction to proceed and catalyzes the conversion of substrate to product. Thereafter, the product departs from the active site of the enzyme. The enzyme is then free to take another substrate molecule into its active site.



*Fig 2.31: Induced fit between an enzyme and its substrate*

### **Cofactors**

Non-proteinous components which are essential for the catalytic activities of certain enzymes are called cofactors.

These cofactors bind to the enzymes in two ways. Some tightly bind and remain permanently and others loosely bind temporarily. Loosely bound cofactors are reversible under certain circumstances.

Organic cofactors are called co-enzymes. e.g. derivatives of vitamins e.g. NAD, FAD and biotin

Inorganic co-factors – e.g.  $Zn^{2+}$ ,  $Fe^{2+}$ ,  $Cu^{2+}$

### **Factors affecting the rate of enzymatic reactions**

1. Temperature
2. pH
3. Substrate concentration
4. Enzyme concentration
5. Inhibitors

### **Temperature**

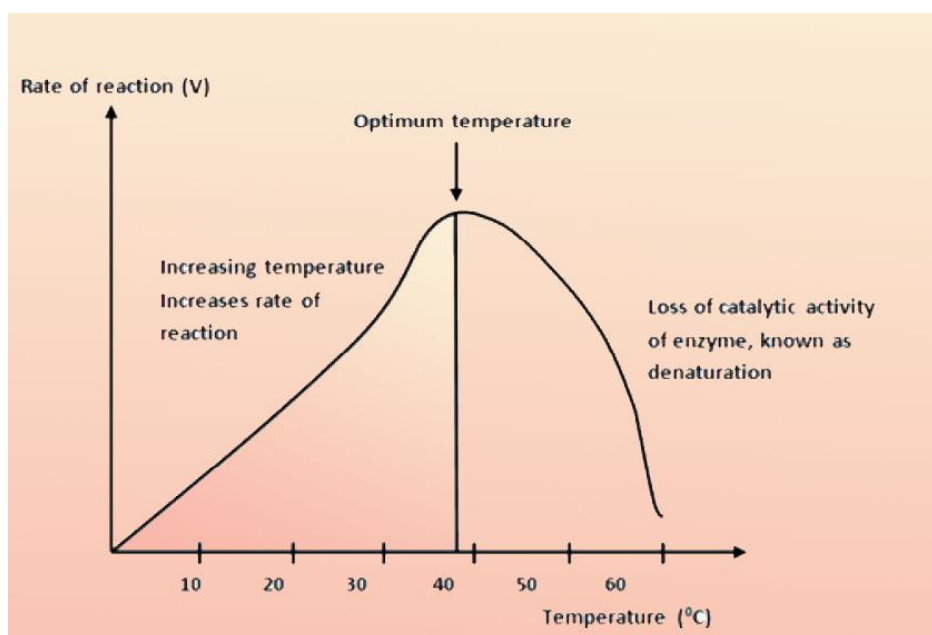
Increase in temperature increases molecular motion. Therefore the speed of the moving molecules of both enzymes as well as the substrate will be accelerated. This will enhance the colliding probability for both enzyme active sites and substrate molecules. More collision between the enzyme active sites and substrate molecules generate greater chances for the reaction to occur. This can continue up to a certain

point, after which there is a rapid decline in enzyme activity. This point is referred to as optimum temperature. This may vary from organism to organism.

e.g. most of the human enzymes have optimum temperature around the body temperature (35°C-40°C). Optimum temperature of bacteria in hot springs is about 70°C.

When the temperature increases beyond the optimum temperature, the hydrogen bonds, ionic and other weak chemical bonds of enzyme active sites may be disrupted. This will result a change in the shape of the active site of enzyme which will alter the complementary nature of the active site of enzyme molecules. Therefore, the complementary binding of enzyme active sites and substrate molecules will be prevented. The above event is called as denaturation of enzyme molecules.

Therefore the rate of enzyme catalyzed reaction will start to decline when the temperature increases beyond the optimum temperature and stops completely at certain temperature, although rate of collision will keep on increasing.



*Fig -2.32 The graph of Rate of reaction (V) vs Temperature(T)*

## pH

Enzymes function most efficiently within a certain pH range despite maintaining temperature of the environment constant.

The narrow range of pH in which a particular enzyme catalyzed reaction takes place is named as the pH range. The pH at which the highest rate of reaction occurs is the optimum pH of the enzyme. The alteration in pH above or below the optimum pH may lead to decline in enzyme activity. This is due to the alteration of chemical bonds involving in formation of enzyme substrate complex. In most enzymes optimum pH range is 6-8, but there are exceptions. Pepsin works best at pH 2 and optimum pH for Trypsin is 8.

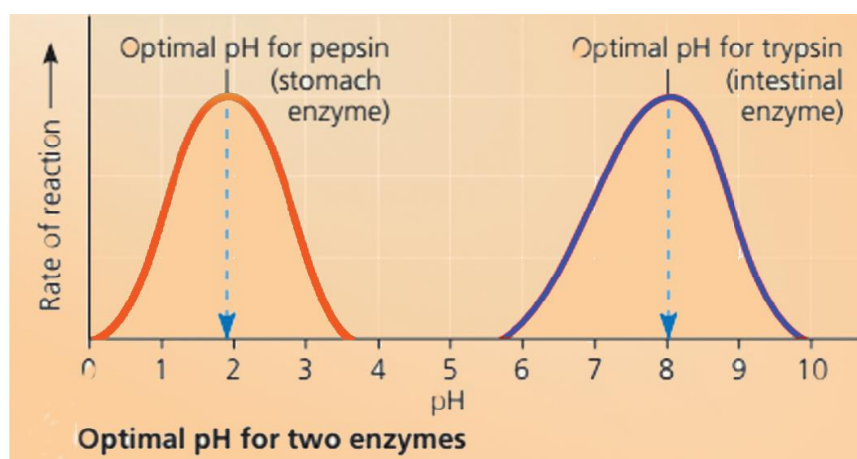


Fig 2.33- Rates of reaction of two enzymes at various pH values

### Substrate concentration

Increasing substrate concentration increases the probability of collision between the enzyme and substrate molecules with correct orientation. However the enzyme molecules will be saturated after a particular concentration and therefore there will not be any further increase in the rate of reaction.

### Enzyme inhibitors

Certain molecules or ions selectively bind permanently or temporarily to the enzyme molecules and prevent them from forming enzyme-substrate complex. These substances are called inhibitors.

They are either binding reversibly with weak interactions or binding irreversibly through covalent bonds.

e.g. Irreversible inhibitors: toxins, poisons

Reversible inhibitors- drugs used against microbes

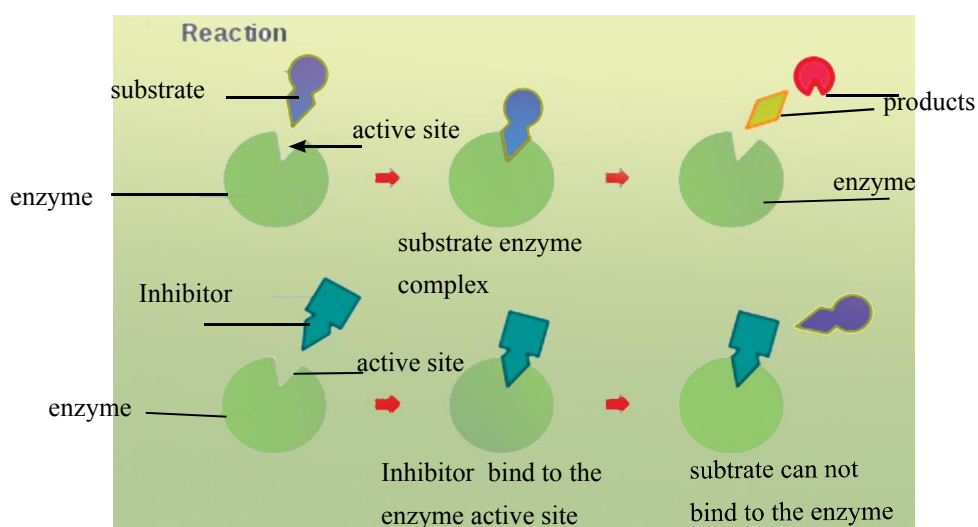
### Competitive inhibitors

Most of these are reversible inhibitors. These chemicals resemble the shape and nature of the substrate. Therefore they compete with the substrate selectively for the active site of certain enzymes. As a result of the above, the number of active sites available for the enzymes may decline and therefore reduces the rate of enzyme catalyzed reactions.

The above situation may be reversed by increasing the substrate concentration.

e.g. Protease inhibitor of drugs against HIV.-change

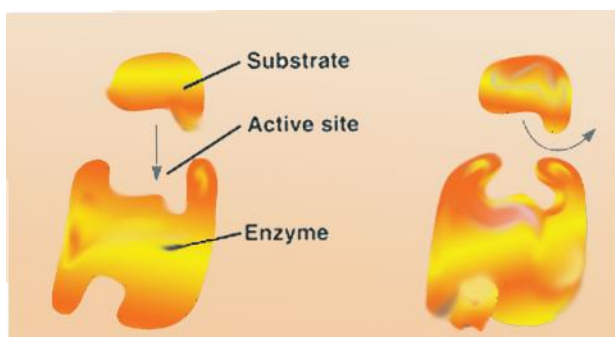




*Fig 2.34: Competitive inhibitors*

### Non-competitive inhibitors

These chemicals do not compete with substrate molecules. They interrupt enzymatic reaction by binding to a part of the enzyme other than the active site. This causes the enzyme molecule to change its shape in such a way that the active site becomes less effective for the formation of enzyme substrate complex.



*Fig 2.35: noncompetitive inhibitors*

## Regulation mechanism of enzymatic activity in cells

### Allosteric regulation of enzymes

In many cases, the molecules that naturally regulate enzyme activity in a cell behave like reversible non-competitive inhibitors. Regulatory molecules (either activators or inhibitors) bind to specific regulatory sites elsewhere (other than the active site) of the molecule via non-covalent interactions and affect the shape and function of the enzyme. It may result in either inhibition or stimulation of an enzyme activity.

**a.) Allosteric activation and inhibition**

Most enzymes regulated by allosteric regulation are made from two or more subunits. Each sub unit composed of a polypeptide chain with its own active site. The entire complex oscillates between two different shapes one catalyzing active and other inactive. In this two forms regulatory molecules bind to a regulatory site called allosteric site, often located where subunits join.

When an activator binds with this regulatory site, stabilizes the shape with functional active sites. Whereas the inhibitor binds with the regulatory site, it stabilizes the inactive form of enzyme. Subunits of enzyme arranged in a way through which they transmit the signals quickly other subunits. Through the interaction of subunits even a single activator or inhibitor molecule that bind to one regulatory site will affect the active site of all sub units. e.g. ADP function as allosteric activator bind to the enzyme and stimulates the production of ATP by catabolism. If the supply of ATP exceed demand catabolism shows down as ATP bind to the same enzyme as inhibitor.

**b.) cooperativity**

This is another type of allosteric activation. Binding of one substrate molecule can stimulate binding or activity at other active site. Thereby increase the catalytic activity. e.g. hemoglobin (not an enzyme) is made up of four subunits each with an O<sub>2</sub> binding site. The binding of a one molecule of O<sub>2</sub> to one binding site increases the affinity for O<sub>2</sub> of the remaining binding site.

**c.) Feedback inhibition**

In feedback inhibition, a metabolic pathway is stopped by the inhibitory binding of its end product of a process to an enzyme. Thereby limit the production of more end products than required and thus wasting chemical resources.

**Feedback inhibition**

Feedback inhibition is an essential process regulates the end products produced in metabolism.

e.g. ADP function as allosteric activator and stimulates the production of ATP during the catabolism.

In case ATP supply exceeds demand, catabolism slows down as ATP molecules function as allosteric inhibitor.

Energy needed for all living processes is obtained directly from ATP. ATP is mainly produced by a process call ed cellular respiration, in living cells.

## Photosynthesis as an energy fixing mechanism

### Photosynthesis

Photosynthesis is a metabolic process by which light energy is trapped and converted to chemical energy. Chemical energy is stored in chemical bonds of carbohydrates, fats, oils, and proteins. All life on Earth depends on photosynthesis either directly or indirectly. Photosynthesis also occurs in algae and certain prokaryotes.

Global importance of photosynthesis;

- All life on earth depends on photosynthesis, directly or indirectly
- Fulfill both carbon and energy requirements of organisms
- Provide O<sub>2</sub> for respiration of aerobic organisms
- Maintain O<sub>2</sub> and CO<sub>2</sub> balance in the atmosphere
- Production of fossil fuel
- Maintenance of global temperature

During photosynthesis CO<sub>2</sub> is reduced by the H of H<sub>2</sub>O and simple sugars are made using light energy. In eukaryotic photosynthetic cells, chloroplasts are the sites of photosynthesis.

Process of photosynthesis consists of two main stages and they are integrated.

- Light-dependent reaction
- Calvin cycle

There are two types of photosynthetic mechanisms (path ways) based on the number of C atoms of the first stable product of the CO<sub>2</sub> fixation.

- C<sub>3</sub> Mechanism – No of C atom of the first stable compound is three
- C<sub>4</sub> Mechanism – No of C atom of the first stable compound is four

Light-dependent reactions of photosynthesis take place in the membrane system of thylakoids. They are flattened fluid-filled sacs, which form stacks called grana at intervals. Chlorophylls, carotenoids and electron acceptors are located on this membrane system of thylakoids.

Stroma is a gel like structure containing soluble enzymes and other chemicals, which is the site of the Calvin cycle.

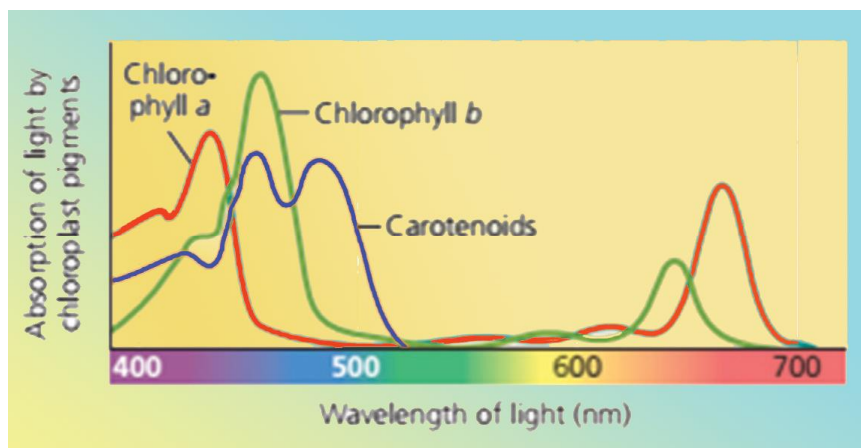
Photosynthetic pigments are substances which absorb visible light. In a leaf we see green colour because chlorophylls absorb violet, blue and red light and therefore, they transmit and reflect green colour. Different pigments absorb different wavelengths of light. In chloroplast, there are two types of chloroplast pigments such as chlorophylls and carotenoids. Chlorophyll a is the key light capturing pigment and they participate directly in the light reaction of photosynthesis.

According to the action spectrum, chlorophyll a is more effective for blue and red light. Chlorophyll b and carotenoids (carotenes and xanthophylls) are effective in absorption of specific range wavelengths of corresponding to different colours.

Other important function of some carotenoids is photoprotection. Photoprotection is absorption and dissipation of excessive light energy, if not that excessive light may cause damage to the chlorophylls or interact with oxygen and form reactive oxidative molecules which are dangerous to the cell.

### Absorption spectrum

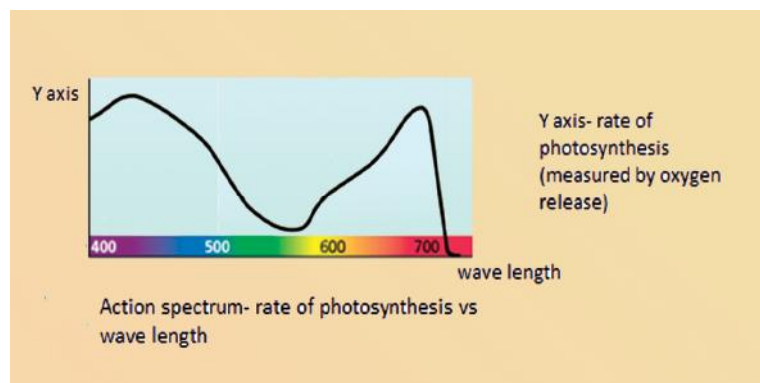
An absorption spectrum is a graph of the relative amounts of light absorbed at different wavelengths by a pigment.



*Fig. 2.36: Absorption spectrum*

### Action spectrum

An action spectrum is a graph showing the effectiveness of different wave lengths of light in stimulating the photosynthesis.



*Fig 2.37: Action spectrum*

### Excitation of chlorophyll by light

When a molecule of chlorophyll or other photosynthetic pigment absorbs light it becomes excited. The energy from the light is used to boost electrons to a higher level and become positively charged. The excited state is unstable and returns to their original lower energy state. The excited electrons may pass through several electron carriers until they reach the final electron acceptor.



Therefore chlorophyll is oxidized and electron acceptor is reduced.

### Photosystems

Chlorophyll molecules, other organic molecules and proteins are organized into complexes in the thylakoid membrane of chloroplasts. They are called photosystems.

A photosystem contains a reaction centre complex and light harvesting complexes. The reaction centre complex also contains a primary electron acceptor.

There are two types of photosystems found in the thylakoid membrane. They are Photosystem I (PS I) and photosystem II (PS II). In the PS I the chlorophyll a molecule is known as P700 since they absorb light at 700nm wave length effectively. In the PS II the reaction centre contains a chlorophyll a molecule which is known as P680 which absorbs light having a wavelength of 680 nm.

### Light-dependent reaction /Light reaction photosynthesis

#### Linear electron flow

Light is absorbed by the photosynthetic pigments and synthesize ATP and NADPH due to the excitation of Photosystem I and Photosystem II which are embedded in the thylakoid membrane of chloroplast. The key to this energy transformation is a flow of the electron in one direction through the photosystems and other molecular components built in the thylakoid. This process is called linear electron flow.

The striking of photons of light on the pigments results in the excitation of electrons from the photosystem II to the higher energy state.

These electrons will be accepted by the primary electron acceptor of photosystem II. Splitting of water takes place as a result of an enzyme catalyzed reaction and yields O<sub>2</sub> (g), H<sup>+</sup> ions and electrons.

Electrons released as a result of hydrolysis may neutralize excited photosystem II (P680).

Striking of photons of light on the pigments results in the excitation of electrons from photosystem I (P700) to the higher energy state. Excited electrons will be accepted by a primary electron acceptor of PSI.

Excited electrons of PS II at primary electron acceptor of PS II will pass through an electron transport chain to PS I and neutralize the excited PS I. The energy released due to the passage of electrons from higher energy state to lower energy result in the synthesis of ATP. This is known as photophosphorylation. Excited electrons of PS I at primary electron acceptor of PSI will pass through an electron transport chain and

reduce NADP and yield NADPH. The reduction of NADP is catalyzed by an enzyme called NADP reductase.

### Cyclic electron flow

This occurs in photosystem I but not in Photosystem II. Here some photoexcited electrons use alternative cyclic pathway. This produces ATP but not NADPH and Oxygen are released.

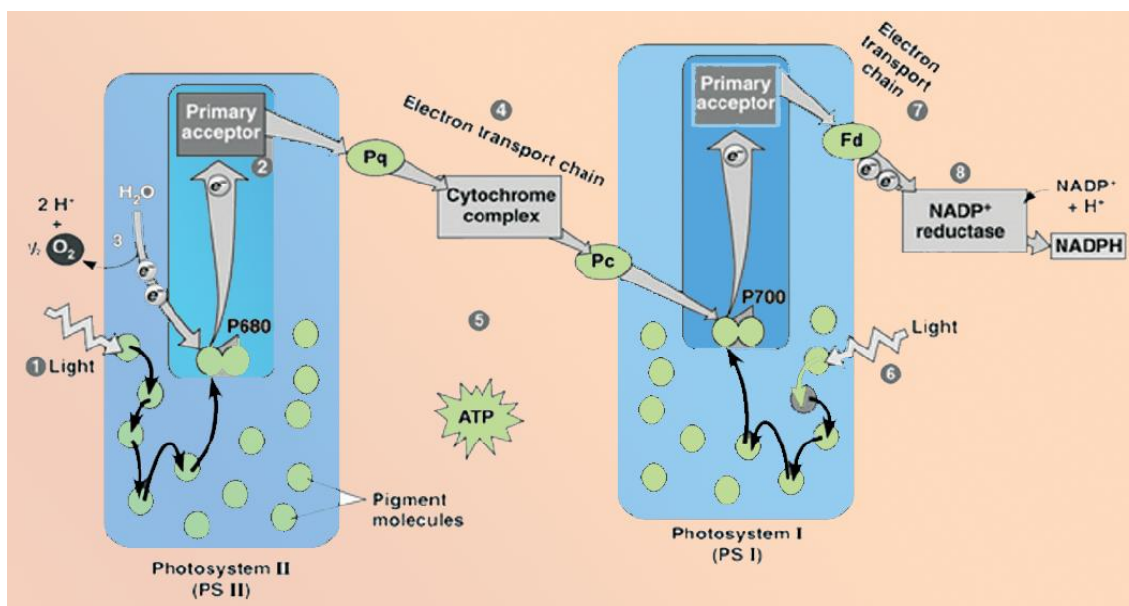


Fig 2.39 : Linear electron flow in the light reaction of photosynthesis

### The Calvin cycle

The Calvin cycle takes place in the stroma of the chloroplast. Energy from ATP and NADPH produced by the light reaction are used to reduce  $\text{CO}_2$ . The reactions are catalyzed by enzymes and their sequence was discovered by scientist Calvin. This is an anabolic reaction. The first stable product of the Calvin cycle is glyceraldehyde 3-phosphate (G3P). For the net synthesis of one molecule of G3P, the cycle must take place three times.

The Calvin cycle of photosynthesis can be described in three steps;

- Carboxylation (Carbon fixation)
- Reduction
- Regeneration of carbondioxide acceptor

### Carbon fixation

The  $\text{CO}_2$  acceptor is a 5 C sugar, Ribulose biphosphate (RuBP). The addition of  $\text{CO}_2$  to a RuBP is called carboxylation. The enzyme involved in this reaction is RuBP carboxylase oxygenase or Rubisco.

The first product of RuBP carboxylation is a 6C molecule which is unstable and breaks down immediately into two molecules of 3-phosphoglycerate (3-PGA). This is the first stable product of photosynthesis. The enzyme RuBP carboxylase oxygenase (Rubisco) is present in large amounts in the chloroplast stroma.

### **Reduction phase**

1,3-Bisphosphoglycerate will be reduced to Glyceraldehyde 3-phosphate (G3P) through step by step. Enzyme catalyzed reactions utilizing NADPH and ATP from light reaction. G3P will act as a precursor for carbohydrate synthesis (glucose).

### **Regeneration of RuBP**

RuBP is regenerated by undergoing a series of complex reactions. This process uses energy from ATP generated in light reaction.

### **Photorespiration**

As its name suggests, Rubisco is capable of catalyzing two distinct reactions, acting as both a carboxylase and as an oxygenase.

In the oxygenase reaction of Rubisco uses the same substrate, RUBP, but reacts it with  $O_2$ . The reaction is catalyzed on the same active site as the carboxylation reaction. Thus  $CO_2$  and  $O_2$  are competitive substrates. Therefore  $CO_2$  inhibits the oxygenase and  $O_2$  inhibits the carboxylase reaction.

The oxygenase reaction forms just one molecule of 3-PGA plus a two carbon product, 2-phosphoglycolate which is of no immediate use in the Calvin cycle and in higher concentrations it is toxic for the plant. It therefore has to be processed in a metabolic pathway called photorespiration. The photorespiratory pathway involves enzymes in the chloroplasts, peroxisome and mitochondria. (detail of this pathway is not expected).

Photorespiration is not only energy demanding, but furthermore leads to a net loss of  $CO_2$ . Each time Rubisco reacts with  $O_2$  instead of  $CO_2$  the plants makes 50% less 3-PGA than it would have done if  $CO_2$  had been used. This potentially eliminates the net gain in photosynthetic carbon and loses the productivity.

These two factors result in an increase in photorespiration relative to photosynthesis so that an increasing proportion of carbon is lost as the temperature rises.

The  $CO_2$  required for photosynthesis enters a leaf via stomata. However, stomata are also the main avenues of transpiration. On a hot, dry day, most plants close their stomata in order to conserve water. At the same time  $O_2$  released from the light reactions begins to increase and this leads to further reduction of ( $CO_2$ ) to ( $O_2$ ) ratio in the cytosol. These conditions within the leaf favor a wasteful process photorespiration under high temperature, dryness and high light intensities.

Therefore plants developed different way to cope with this situation during the evolution that resulted a most successful solution to concentrate  $\text{CO}_2$  around Rubisco provided by  $\text{C}_4$  photosynthetic pathway.

The establishment of  $\text{C}_4$  photosynthetic pathway includes several biochemical and anatomical modifications that allow plants with this pathway to concentrate  $\text{CO}_2$  at the site of Rubisco. Thereby its oxygenase reaction and the following photorespiration are largely repressed in  $\text{C}_4$  plants.

In most  $\text{C}_4$  plants the  $\text{CO}_2$  concentration mechanism is achieved by a division of labor between two distinct specialized leaf cell types, the mesophyll and the bundle sheath cells. Compared to  $\text{C}_3$  plants the bundle sheath cells of  $\text{C}_4$  plants have expanded physiological functions. This is reflected by the enlargement and higher organelle content of these cells in  $\text{C}_4$  species. For the efficient function of the  $\text{C}_4$  pathway a close contact between mesophyll and bundle sheath cells are tightly interconnected to each other by high numbers of plasmodesmata. The bundle sheath cells enclose the vascular bundles and are themselves surrounded by the mesophyll cells and this type of leaf anatomy was termed Kranz anatomy.

Since Rubisco can operate under high  $\text{CO}_2$  concentrations in the bundle sheath cells, it works more efficiently than in  $\text{C}_3$  plants. Because of the  $\text{CO}_2$  concentration mechanism they can acquire enough  $\text{CO}_2$  even when keeping their stomata more closed and minimize the water loss by transpiration.

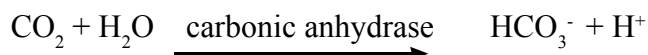
#### **$\text{C}_4$ pathway of photosynthesis**

In the mesophyll cells of  $\text{C}_4$  plants  $\text{CO}_2$  is converted to bicarbonate by carbonic anhydrase and initially fixed by phosphoenolpyruvate carboxylase using PEP as  $\text{CO}_2$  acceptor. The resulting oxaloacetate (OAA) is composed of four carbon atoms, which is the basis for the name of this metabolic pathway. Oxaloacetate is rapidly converted to the more stable  $\text{C}_4$  acids malate or aspartate that diffuse to the bundle sheath cells. Here,  $\text{CO}_2$  is released by decarboxylating enzymes and the released  $\text{CO}_2$  is refixed by Rubisco, which exclusively operates in the bundle sheath cells in  $\text{C}_4$  plants.

Chloroplasts found in mesophyll cells are different in anatomy in comparison to chloroplasts of bundle sheath cells.

Since chloroplasts of mesophyll cells carryout only light reaction, they are rich in grana. The grana of mesophyll chloroplasts are large and highly differentiated for light reaction. Bundle sheath chloroplasts possess a very few, less differentiated grana or grana are absent. Moreover, that PSII in the bundle sheath cells are depleted in order to lower oxygen production in these cells.





This PEP carboxylase enzyme is much more efficient than the enzyme of RUBP carboxylase for two reasons.

1. It reacts with bicarbonate ( $\text{HCO}_3^-$ ) rather than with  $\text{CO}_2$ . The advantage of this is that there is a 50-fold higher concentration of  $\text{HCO}_3^-$  than  $\text{CO}_2$  in solution in the cytosol.
2. It has no affinity for  $\text{O}_2$

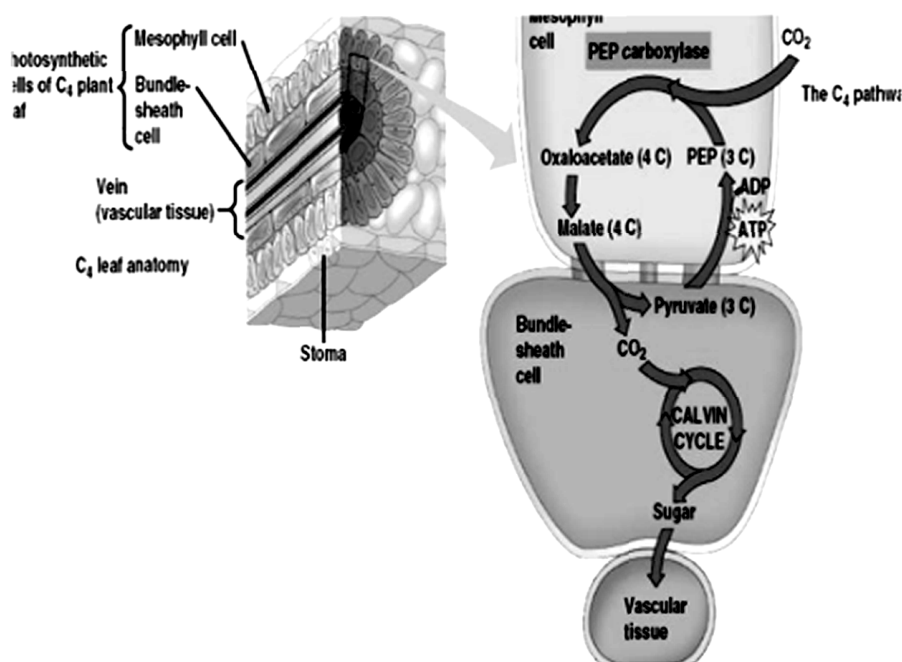


Fig 2.39 : The C4 Pathway

### Significance of the C4 pathway

- Helps plants to improve the efficiency of  $\text{CO}_2$  fixation at lower  $\text{CO}_2$  concentrations by preventing the gateways for photorespiration by spatially separating Rubisco.
- In hot-dry climate, it is essential for the stomata to close to prevent water loss through transpiration. This reduces  $\text{CO}_2$  intake of particular plants. Therefore, plants in tropical zones or hot climate may suffer from  $\text{CO}_2$  deficiency. At lower  $\text{CO}_2$  concentrations, C4 mechanism increases the efficiency of photosynthesis by concentrating  $\text{CO}_2$  in the bundle sheath cells.

C4 plants exhibit better water-use efficiency than C3 plants because of the CO<sub>2</sub> concentration mechanism they can acquire enough CO<sub>2</sub> even when keeping their stomata more closed. Thus water loss by transpiration is reduced.

Since Rubisco can operate under high CO<sub>2</sub> concentrations in the bundle sheath cells, it works more efficiently than in C3 plants, consequently C4 plants need less of this enzyme, this leads to a better nitrogen-use efficiency of C4 compared to C3 plants.

**Table 2.6: Comparisons of C3 and C4 plants**

Characteristics	C3 plants	C4 plants
Representative species	Wheat, rice barley	Maize, sugarcane, grasses
Temperature optimum for photosynthesis (°C)	15-25	50% greater at 35 °C
CO <sub>2</sub> fixation	Occurs once	Occurs twice, first in mesophyll cells, second in bundle sheath cells
CO <sub>2</sub> acceptor	5C, RuBP	3C, PEP mesophyll cells 5C RuBP in bundle sheath cells
CO <sub>2</sub> fixing enzyme	Rubisco	PEP carboxylase in mesophyll cells which is very efficient Rubisco in bundle sheath cells, working efficiently under high CO <sub>2</sub> concentration
First product of CO <sub>2</sub> fixation	C3 acid, 3- phosphoglycerate (3-PGA)	4C acid, oxaloacetate (OAA)
Leaf anatomy	Bundle sheath cells, if present, are not green (non photosynthetic), photosynthesis occurs in Mesophyll cells	Kranz anatomy with photosynthesis occurring in both mesophyll cells and bundle sheath cells
Productivity	Yield is usually lower	Yield is usually high

### Factors affecting photosynthesis

The rate of photosynthesis is an important factor in crop production. Rate is affected by various factors.

e.g. light intensity, CO<sub>2</sub> concentration, temperature, water, pollutants and inhibitors

The photosynthesis involves a series of reactions. Therefore various factors are involved in it.

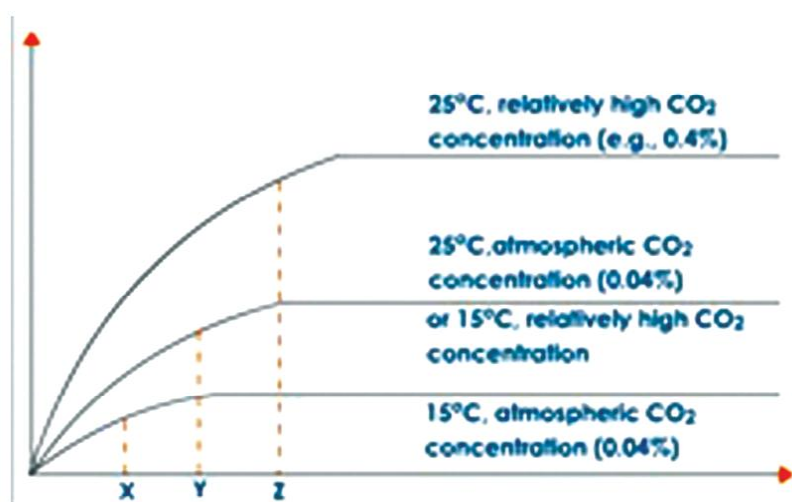
Blackman who is the scientist first proposed the idea of principal of limiting factors.

When a chemical process is affected by more than one factor, its rate is limited by the factor which is nearest its minimum value.

e.g. Light intensity

### Light Intensity

The rate of photosynthesis increases linearly with increasing light intensity. Gradually the rate of increase falls off as the other factors become limiting. Very high light intensities chlorophyll may bleach and slow down photosynthesis. However, plants exposed to such conditions are usually protected by devices such as thick cuticles, hairy leaves.



*Fig 2.40: Rate of photosynthesis with light intensity at different temperatures*

Under normal conditions, CO<sub>2</sub> is the major limiting factor in photosynthesis. Increase in photosynthetic rate is achieved by increasing CO<sub>2</sub> concentration. For example some greenhouse crops such as tomatoes are grown in CO<sub>2</sub> enriched atmosphere.

## Cellular respiration as a process of obtaining energy

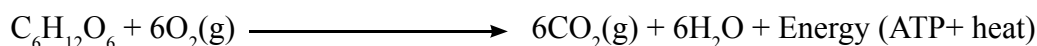
Cellular respiration is the process by which chemical energy in organic molecules such as carbohydrates is released by stepwise oxidative process, catalyzed by enzymes and made available in living cells in the form of ATP. Cellular respiration is divided as

- a) aerobic respiration
- b) anaerobic respiration

### Aerobic respiration:-

The process of synthesizing ATP from the respiratory substrates such as glucose in the presence of molecular oxygen (O<sub>2</sub>) known as aerobic respiration. Glucose is found to be the major respiratory substrate in living cells.

The aerobic respiration of glucose molecules can be represented by the following balanced chemical equation.



This process consists of three main steps. They are;

- a) Glycolysis
- b) Pyruvate oxidation and citric acid cycle (Kreb's cycle)
- c) oxidative phosphorylation (Electron transport chain)

### Glycolysis

It takes place in the cytosol of the cell, because all enzymes that catalyze reactions of the glycolysis are found in the cytosol of the cell. This process does not depend on O<sub>2</sub>. During the above process a six carbon (6C) glucose molecule is broken down step by step into two three-carbon (3C) pyruvate molecules.

Two ATP molecules are used up to initiate the process.

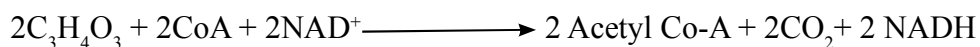
Four hydrogen molecules and electrons released from glucose breakdown reduce two NAD<sup>+</sup> and produce two NADH. At the end of glycolysis there will be four ATP molecules produced. Since two ATP molecules were used up for the initiative step, the net yield will be two ATP molecules.

Only when O<sub>2</sub> is present, the pyruvate molecules will enter the mitochondria and further steps will take place.

### Oxidation of Pyruvate/ Link reaction

These two pyruvate molecules enter mitochondrion by active transport through the membrane. In the matrix of mitochondria, Pyruvate is converted to acetyl group by releasing two CO<sub>2</sub> molecules. Then this acetyl group combines with co-enzyme A to

produce Acetyl co-A. In this reaction two  $\text{NAD}^+$  is converted to two NADH molecules. Therefore this step can be represented as follows.

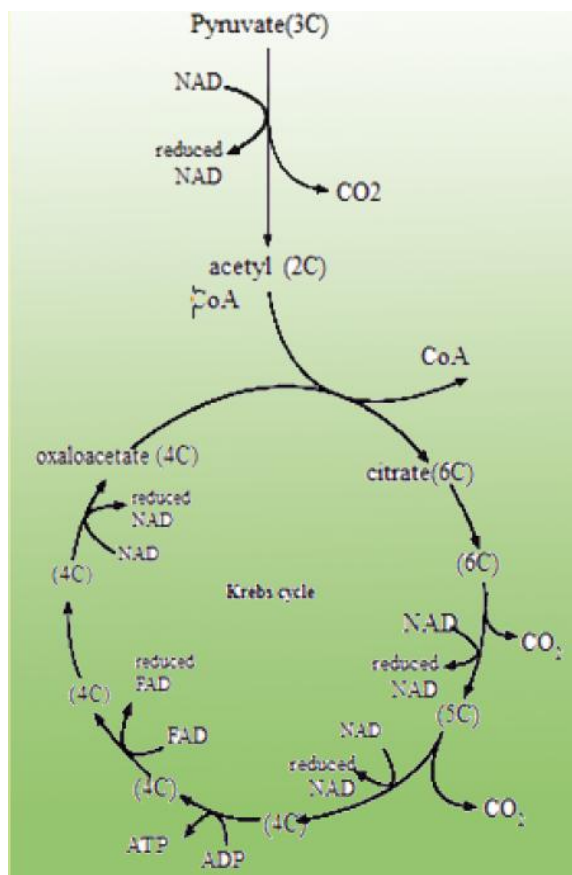


Oxidation of pyruvate is a linking reaction of glycolysis and citric acid cycle.

Acetyl Co-A will feed its acetyl group for citric acid cycle.

### Citric acid cycle

This takes place in the matrix of mitochondria using specific enzymes. As the first product of this cyclic pathway is citric acid, it is known as citric acid cycle. The pathway was discovered by a German-British scientist Hans Krebs. Hence, it is named as Krebs' cycle. Citric acid contains three carboxylic acid groups. This cycle is also known as Tricarboxylic Acid cycle or TCA cycle. In the citric acid cycle 4 C compound oxaloacetate combines with 2 C compound acetyl Co -A to form 6 C compound, citric acid. Then citric acid undergoes a series of reactions to regenerate oxaloacetate by releasing two  $\text{CO}_2$  molecules by decarboxylation reaction. One ATP molecule is produced by substrate level phosphorylation. One  $\text{FADH}_2$  and three NADH will be generated as a result of oxidation reactions. These are the products of a single acetyl group led into citric acid cycle and hence these numbers should double when the yield for a glucose molecule is considered.



*Fig 2.41: Krebs cycle (mechanism is not necessary for the examination)*

### Electron transport chain

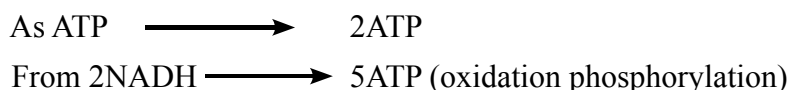
This step is taken place across the inner membrane (cristae) of mitochondria. The folding of cristae increases surface area for oxidative phosphorylation. NADH and  $\text{FADH}_2$  products in the early stages of aerobic respiration are oxidized by transferring electrons, through the electron transport chain and finally to molecular oxygen ( $\text{O}_2$ ). The electron transport chain is located in the inner membrane of mitochondrion and composed of series of protein and non-protein molecules involving in the movement of electrons and protons across cristae. Therefore, the Molecular oxygen ( $\text{O}_2$ ) is the final electron acceptor in aerobic respiration. In the electron transport chain, ATP is synthesized by oxidative phosphorylation.

In this electron transport chain, energy is released progressively from NADH and  $\text{FADH}_2$  and that energy is used to synthesize ATP. When one molecule of NADH is oxidized in the electron transport chain, 2.5 molecules of ATP in average are generated due to oxidative phosphorylation. When one molecule of  $\text{FADH}_2$  is oxidized 1.5 molecules of ATP in average are produced due to oxidative phosphorylation. Total number of ATP that is produced in this step is 28.

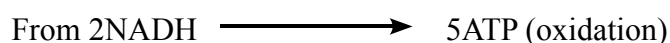
This is true in the active cells such as liver cells and cardiac muscle cells but not in other cells where two ATP produced in glycolysis is used to transport 2NADH from cytosol to mitochondrial matrix. In those cells total number of ATP produced by one molecule of glucose is  $(32-2) = 30$  ATP.

Total number of ATP molecules produced from one molecule of glucose, during aerobic respiration.

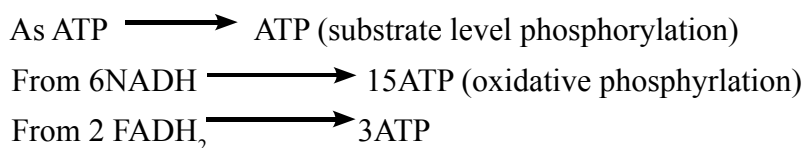
In glycolysis;



In pyruvate oxidation;



In Citric acid cycle;



$$\therefore \text{Total Number of ATP} = 32 \text{ ATP}$$

### Anaerobic respiration

Anaerobic respiration is breaking down of glucose in the absence of molecular oxygen which is regulated by enzymes of the cells occurring in cytosol. In the absence of molecular oxygen pyruvate molecules cannot be broken down further. ATP generated is utilized to fulfill energy requirements. However, NADH produced during glycolysis cannot be utilized. Therefore, since  $\text{NAD}^+$  is limited it is essential for the cell to recycle NADH to enhance the availability of  $\text{NAD}^+$  other than anaerobic respiration

fermentation is a method of production of ATP in the absence of  $O_2$ . There are many types of fermentation, differing from end products formed by pyruvate. The two common types are;

1. Ethyl alcohol fermentation
2. Lactic acid fermentation

### **Ethyl alcohol fermentation**

- Like in aerobic respiration, the first step of this is also Glycolysis.
- Therefore one molecule of glucose is converted to 2 molecules of pyruvate giving 2 molecules of ATP and two molecules of NADH
- Then this pyruvate involve in two steps. In the 1st step pyruvate is converted in to Acetylaldehyde, releasing a molecule of  $CO_2$ .
- In the second step acetylaldehyde is reduced to ethanol using NADH that is produced in Glycolysis.
- Therefore final hydrogen acceptor in ethyl alcohol fermentation is acetylaldehyde (organic compound)
- Many bacteria carry out ethyl alcohol fermentation. The most common organism which carries out ethyl alcohol fermentation is yeast.

### **Lactic acid fermentation**

- As in ethyl alcohol fermentation, Glycolysis takes place as the first step of lactic acid fermentation.
- Therefore one molecule of glucose produces two molecules of pyruvate, two molecules of ATP and two molecules of NADH.
- Then pyruvate is reduced directly by NADH for lactic acid as an end product with no release of  $CO_2$ . Therefore final H acceptor is also organic compounds.
- Certain fungi and bacteria carryout lactic acid fermentation but the most common organisms are lactic acid bacteria involved in formation of yoghurt and curd.

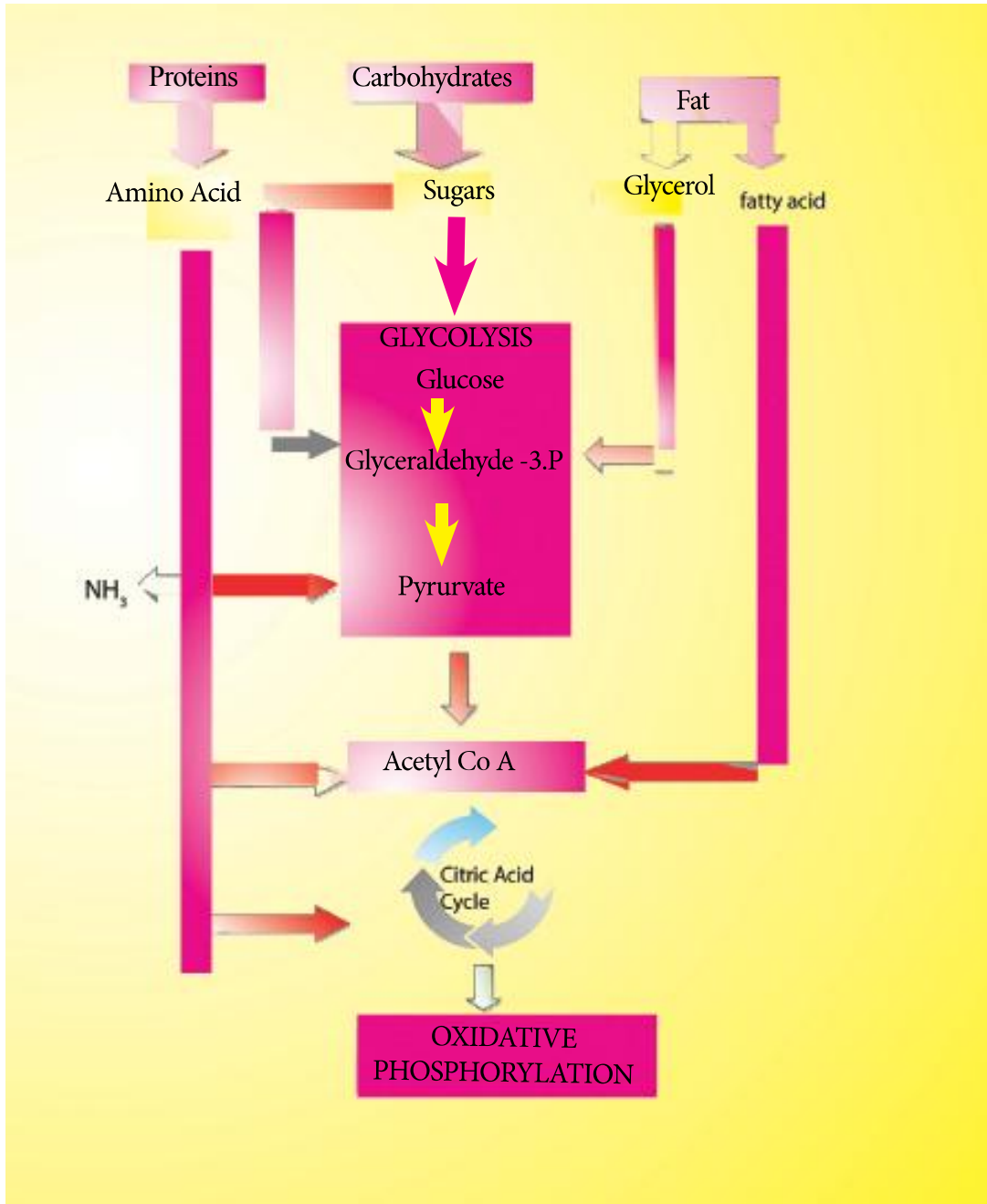
### **Respiratory quotient**

It is the ratio of  $CO_2$  evolved and the volume of  $O_2$  consumed in a given time for the respiratory substrate.

$$RQ = \frac{V \text{ CO}_2}{V \text{ O}_2}$$

RQ of respiration of carbohydrates, fats and proteins are 1.0, 0.7 and 0.8 respectively.

**Use of proteins, Carbohydrates, fats in respiration**





# 03

## Evolution and Diversity of Organisms

### The theories of origin of life and natural selection to analyze the process of evolution of life

#### Origin of life on earth

##### Condition of earth before life

Earth and the other planets of the solar system were formed about 4.6 billion years ago. At the beginning of the solar system, planet Earth was being bombarded by chunks of rocks and ice.

The first atmosphere was probably thick with water vapour, along with various compounds released by volcanic eruptions, including nitrogen and its oxides, carbon dioxide, methane, ammonia, hydrogen and hydrogen sulphide. The neutral atmosphere then turned to be a reducing one. The first atmosphere had little oxygen. Later earth was cooled down and the water vapour condensed into the ocean. Some of the hydrogen quickly escaped into the space. Volcanic eruptions, lightening, extreme UV radiation, hydro thermal vents and alkaline vents along with the Earth's reducing atmosphere favored the synthesis of organic molecules essential for the origin of life. These simple organic molecules then polymerized to form macromolecules such as proteins and nucleic acids. Further, the formation of self-replicating organic molecules made life possible on earth.

#### Evolution of Biological Diversity

##### 1. Biochemical evolution

Direct evidence for life on early earth comes from fossils of micro-organisms that are about 3.5 billion years old. Observations and experiments in chemistry, geology and physics have provided evidence, for the appearance of the first living cells. The theory of the biochemical evolution arose from the hypothesis based on chemical and physical processes on early earth. The emerging force of natural selection could have produced the first cells through a sequence of four main stages.

1. Atmospheric conditions of early earth facilitated the abiotic synthesis of small organic molecules such as amino acids and nitrogenous bases from inorganic molecules

2. Polymerization of the above small organic molecules leads to the formation of organic macromolecules.

- a. Amino acids  $\xrightarrow{\text{polymerization}}$  proteins
- b. N-base + sugar+ phosphate  $\longrightarrow$  Nucleic acids

3. Organic macromolecules were packed into membranes, to produce protocells

4. Nucleic acids gained self replicating capability, which made inheritance possible for the cells.

## 2. Origin of protocell

Haldane suggested that the early oceans were a solution of organic molecules “primitive soup” in which life arose. Recent studies related to the volcanic-atmosphere and alkaline vents show the abiotic synthesis of organic molecules. Another source of organic molecules may have been meteorites. RNA accumulated into lipid bound vesicles and formed “protocells” which exhibited enzyme catalyzed activities and were able to grow, replicate and evolve. The early genes and enzymes would have been RNA which enabled replication of RNA. Other molecules that were in the primitive soup were also collected in the protocell. Growth occurred by addition of lipids to the membrane by collision of micelles. When the protocell becomes too large, it divided to form two protocells with RNA included.

## 3. Origin of photosynthetic organisms

Fossils of the first photosynthetic organism, today’s cyanobacteria, originated before 2.7 billion years ago. As a result of photosynthesis iron ( $\text{Fe}^{2+}$ ) ion were oxidized. Once all of the dissolved iron has precipitated, additional  $\text{O}_2$  dissolved in the water until the water bodies became saturated with  $\text{O}_2$ . The increase of photosynthetic bacteria contributed to the increment of the amount of atmospheric oxygen which had accelerated the origin of chloroplast.

## 4. The origin of first eukaryote

The fossils of the first eukaryotic organisms were estimated as from about 1.8 billion years ago. These eukaryotic single cellular organisms later evolved in to multicellular organisms. The appearance of structurally complex eukaryotic cells sparked the evolution of greater morphological diversity than was possible for the simple prokaryotic cells. After the first eukaryotes appeared, a great range of unicellular forms evolved. It gave rise to diversity of some single-celled eukaryotes which evolved in to multicellular forms, such as the varieties of algae, plants, fungi and animals. Fossils of the oldest known protists similar to small red algae were dated as 1.2 billion years ago.

## 5. Diversification of Eukaryotes

Many present day animal phyla appeared in the early Cambrian period. Several animal groups which include, porifera, sponges, cnidarians (Sea anemones and their relatives) and molluscs appeared in the late Proterozoic. According to the DNA analysis, sponges evolved 700 million years ago. Ancestors of arthropods, chordates and other animal phyla originated 670 million years ago. The first food chains on earth appeared when animals started to depend on algae or plants as consumers and with the arrival of many groups of animals, functioning food webs began to appear. Colonization of land by fungi, plants and animals began after about 500 million years ago. Plants that colonized land possess vascular systems to transport water and minerals and water proof coating of wax to prevent the water loss. With the emergence of large trees, differentiation as roots, stems and leaves began and diversified since 40 million years ago. Plants and fungi colonized the land together by interacting with each other. Arthropods (insects and spiders) were the first group of animals to colonize the land. The earliest tetrapods formed about 365 million years ago which were evolved from lobed-finned fish. The divergence of human lineage from other primates was initiated 6-7 million years ago. The origin of the human species took place 195,000 years ago.

### Geological eons and eras of evolution

- Eons: Hadean, Archaean, Proterozoic, Phanerozoic
- Eras: Eon Phanerozoic covers the 3 eras, Palaeozoic, Mesozoic, Cenozoic

#### 1. Hadean eon

- Origin of Earth

#### 2. Archaean eon

- Oldest known rocks on Earth's surface
- Oldest fossils of cells (prokaryotes) appeared
- Concentration of atmospheric oxygen begins to increase

#### 3. Proterozoic eon

- Diverse algae and soft-bodied invertebrate animals appeared
- Oldest fossils of eukaryotic cells appeared

### Eon Phanerozoic covers the 3 eras; Palaeozoic, Mesozoic, Cenozoic

#### 1. Palaeozoic era

- Sudden increase in diversity of many animal phyla
- Marine algae becomes abundant; colonization of land by diverse fungi, plants, and animals
- Diversification of vascular plants
- Diversification of bony fishes, first tetrapods and insects appeared
- Amphibians dominated
- Extensive forests of vascular plants

- First seed plants appeared
- Origin and radiation of reptiles
- Origin of most present-day groups of insects
- Extinction of many marine and terrestrial organisms
- Diversification of early vascular plants

## 2. Mesozoic era

- Cone-bearing plants (gymnosperms) dominated
- Dinosaurs evolved, radiated
- Origin of mammals
- Gymnosperms continued as dominant plants, dinosaurs dominated, abundant and diverse
- Flowering plants (angiosperms) appeared and diversified, many organisms including dinosaurs become extinct

## 3. Cenozoic era

- Major radiation of mammals, birds, and pollinating insects
- Dominance of angiosperm increased and their radiation continued, radiation of most present day mammalian orders
- Origins of many primate groups, continued radiation of mammals and angiosperms, earliest direct human ancestors
- Appearance of bipedal human ancestors
- Origin of genus Homo

## Theories of evolution

Evolution can be defined as a change in the genetic composition of a population from generation to generation (descent with modification) over a long period of time. This may take millions of years.

Theories of evolution are

- Theory of Lamarck.
- Darwin - Wallace theory (Theory of Natural selection)
- Neo Darwinism

## Theory of Lamarck

Lamarck published his hypothesis in 1809. He explained his hypothesis using two principles.

1. Use and disuse
2. Inheritance of acquired characteristics

1. Use and disuse - The parts of the body that are used extensively become larger and stronger. If not used, they deteriorate.  
e.g.- Giraffe stretching its neck to reach leaves on higher branches.
2. Inheritance of acquired characteristics – Organism acquired adaptation during their life time according to the needs of environment. Offspring is better adapted to live in that environment e.g. long muscular neck of the giraffe had evolved over many generations as giraffes stretch their necks even higher

### **Darwin - Wallace theory (Theory of natural selection)**

Darwin observed two phenomena from the environment. His observations were;

The populations of a species vary in characteristics among their inheritance traits.

Each species produces more offspring than their environment could accommodate.

The above observations were interpreted by Charles Darwin as,

Certain traits of a population which are capable of exhibiting qualities for better survival and their reproduction can produce more offspring.

Variation in abilities for survival and reproduction among a population may enhance the abundance of favorable characteristics in that population.

Some favorable characteristics for survival and reproduction are;

- Escaping from predators - defense
- Tolerating physical conditions – stress conditions
- Obtaining food
- Resistance against disease
- Fertilizing probability
- Number of offspring produced

#### **Process of natural selection**

- Over production
- Variation
- Competition and survival of the fittest
- Natural selection of favourable traits

### **Neo-Darwinism**

Neo-Darwinism generally denotes the integration of Charles Darwin's theory of natural selection, Mendelian genetics as the basis for biological inheritance and knowledge of population genetics.

## Hierarchy of taxa on scientific basis

### Methods of artificial and natural classification

Arrangement of organisms into groups on the basis of the common characteristics is called classification. Taxonomy is the scientific study on classification, identification, nomenclature and description. This includes placing groups of organisms in a hierarchical sequence.

Two methods of classification

(1) Artificial classification - grouping is based on a few pre selected unifying characters.

- The characters are selected first according to convenience and organisms are grouped based on the selected criteria
- Evolutionary relationships are ignored
- Only system used before 18th century
- Easy to use, easy to expand by adding more groups

e.g. Plants can be classified as cereals, ornamental plants, medicinal plants, poisonous plants etc. Animals can be classified as two legged, four legged, six legged, eight legged etc.

(2) Natural classification - grouping based on true relationships.

- Represents evolutionary relationships based on phylogeny- evolutionary history of a species or groups of species
- Systems developed after the study of evolution.
- Based on many characteristics.

Characteristics used can be morphological, anatomical, cytological or molecular biological such as DNA and RNA base sequences

e.g. Plants can be classified into phyla; Bryophyta, Lycophyta, Pterophyta, Cycadophyta, Coniferophyta and Anthophyta etc. Animals can be classified into Cnidaria, Platyhelminthes etc.

### History of classification

The early classification systems were all artificial systems and were mostly based on human uses.

Aristotle was the first to classify organisms scientifically. He divided organisms into plants and animals. Animals were further classified according to criteria such as mode of locomotion, reproduction and presence or absence of red blood cells. Aristotle's pupil Theophrastus classified plants according to habit. e.g. trees, shrubs and herbs, and according to lifespan e.g. annuals, biennials and perennials.

Up to the time of Linnaeus scientists have used many different methods for naming of organisms. Carolus Linnaeus(1753), Swedish botanist, introduced binomial nomenclature and also classified about 6,000 plants into a hierarchical order of taxa, classification level such as; Species, genus, order, and class. His classification of flowering plants was based on the number of stamens and styles of flower. He identified two kingdoms of organisms; plants and animals.

With the discovery of the microorganisms the scientists understood that there were organisms which could not be assigned into either plants or animals. To get over this difficulty Ernest Haeckel (1866) introduced a third kingdom: Protista. He also introduced the taxon Phylum and classified many organisms.

With the discovery of the electron microscope biologists identified prokaryotic and eukaryotic cellular organization. Robert H Whittaker (1969) introduced the five kingdom system of biological classification; Monera, Protista, Fungi, Plantae and Animalia. His classification was based on the nature of cellular organization, unicellular or multicellular and mode of nutrition.

With the acceptance of Darwin's theory of the evolution and unitary origin of life, taxonomists began to use natural systems with interpreting evolutionary relationships. With the recent advancement of molecular biology and the use of molecular methods in studying evolutionary relationships it became apparent that in the very early evolution some prokaryotes differ as much from each other as do from eukaryotes. Such difficulties have lead biologists to adopt three Domain system of classification. The three domains are Bacteria, Archea and Eukarya, which are taxonomic ranks higher than the Kingdom. Carl Woese (1977) introduced this three domain system.,

In this tree of life the first major split in the history of life occurred when bacteria diverged from others. Eukarya and Archea are mostly related to each other than bacteria.

### **Present system of classification and its basis**

The present system of classification is mainly based on the rapid advance of molecular biology and the new information on the evolutionary relationships of organisms.

- the sequence of bases of DNA of important genes
- the sequences of bases of DNA of mitochondria and chloroplasts
- the base sequence of ribosomal RNA
- the sequence of amino acids in common proteins
- the molecular structure of cellular components

are used as important taxonomic criteria in modern systematics.

However, the kingdom Protista is not a natural group. It is an artificial group including organisms which have different evolutionary origins.

Viruses do not have cellular organization, and therefore do not belong to any of the kingdoms. They are also an artificial group considered separately.

### Hierarchy of Taxa from Domains to Species

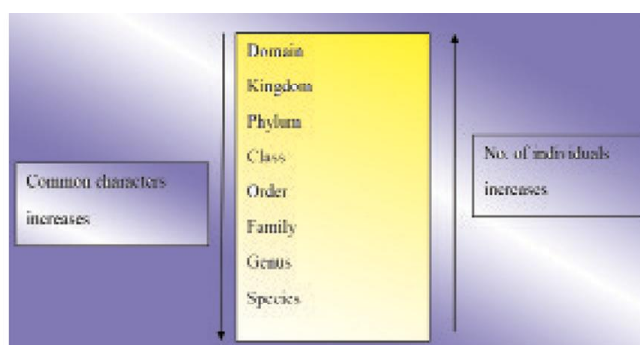
The taxonomic unit at any level/ rank of the hierarchy is called a taxon (plural-taxa). Each taxon has a rank and a name.

e.g. *Panthera* is a taxon at the Genus level/ rank

Mammalia is a taxon at the Class level/ rank

Under the hierarchical system there are levels/ ranks of taxa. Each Domain is divided into kingdoms. A Kingdom is divided into phyla (singular phylum), phylum into classes .etc. Many of these categories may also be subdivided.

e.g. Super class, Sub-family, Subspecies, etc.



From domain to species, the number of shared characteristics among the members in the taxa increases. From species to domain, the number of individuals in the taxon increases.

### Biological definition of a species

Species is a group of organisms who shares similar characteristics and has the ability to interbreed and produce viable and fertile offspring.

### Other definitions of species

- Morphological species concept- use of morphological criteria to distinguish species such as body shape and other structural features



- Ecological species concept—defines species in terms of its ecological niche and the sum of how members of the species interact with the non living and the living components of their environment
- Phylogenetic species concept – defines the species as the smallest group of individuals that share a common ancestor.

### **Binomial nomenclature**

In classification, use of common names for organisms, causes confusion. More over some common names do not actually reflect the kind of organism they signify.

- e.g. Jelly fish (a Cnidarian)  
 Cray fish (a Crustacian)  
 Silver fish (an insect)  
 Star fish (an Echinoderm)

Further, a given organism has different names in different languages. Carolus Linnaeus (1707-1778) proposed a binomial system of nomenclature of species, which was accepted worldwide to avoid ambiguity.

According to the binomial nomenclature the name of an organism has two parts:

First is the generic name, to which the species belongs and the second is a specific epithet, the unique for each species within the genus. Generic name is usually a noun and the specific epithet an adjective describing a particular feature.

e.g. *Homo sapiens*- *Homo* means man, *sapiens* means intelligent

Related species have the same generic name with different specific epithets.

e.g. *Dipterocarpus zeylanicus* and *Dipterocarpus grandiflorus*

*Dipterocarpus zeylanicus* means fruit with two wings, and endemic to Sri Lanka.

*Dipterocarpus grandiflorus* means fruit with two wings and having large flowers.

### **International codes of Binominal nomenclature**

Biologists have adopted sets of rules or Codes of nomenclature. These codes are slightly different for plants, animals, bacteria and viruses. Some of the important rules for naming plants, fungi, bacteria and animals are as follows.

- Two species of organisms cannot have the same name.
- Each species has a generic name and a specific epithet, both together forming the species name or scientific name.
- The Name should be made up of Latinized words written in the Roman script.
- It should be underlined when hand written and italicized when printed.
- The first letter of the generic name must be capitalized the and specific epithet must be in simple letters.

In scientific writing, the name of the author who gave the name is indicated by a capital letter, an abbreviation or full word at the end of the name, which is not Latinized.

e.g. *Cocos nucifera L.*, (L for Linnaeus).

A third word can be used to represent a subspecies or a variety, example *Panthera parduskotiya* (Sri Lankan leopard).

- **Use of keys**
  - Used to group organisms and identify them
  - Keys do not show the evolutionary relationships
  - The Commonly used key is the dichotomous key
  - Some examples are given below

Example 1: **Silverfish, Butterfly, House fly, Beetle**

1. Possesses wings ..... (2)
  - Do not possess wings ..... Silverfish
2. Possess two pairs of wings ..... (3)
  - Do not possess two pairs of wings.....Housefly
3. Possesses a proboscis .....Butterfly
  - Do not possess a proboscis .....Beetle

Example 2: **Snake, Earthworm, Frog, Sea anemone, Butterfly**

1. Radially symmetrical body .....Sea anemone
  - Not having a radially symmetrical body .....(2)
2. Possess legs.....(3)
  - Do not possess legs .....(4)
3. Wings present..... Butterfly
  - Wings absent..... Frog
- 4 Body covered by scales ..... Snake
  - Body is not covered by scales ..... Earthworm

### Domains

There are three domains. They are;

- a) Domain – Bacteria- consists of one kingdom. Kingdom - Bacteria
- b) Domain –Archaea-consists of one kingdom. Kingdom - Archaeobacteria
- c) Domain –Eukarya-consists of four kingdoms.

Kingdom - Protista  
Kingdom - Fungi  
Kingdom - Plantae  
Kingdom - Animalia

### **The diversity of organisms within the Domain Bacteria**

#### **Key characteristics of Domain Bacteria**

- They are prokaryotic
- They are unicellular, colonial, filamentous
- Most of them are found in size between 0.5 to 5µm
- Well adapted to most of the 'normal' habitats (both land and water)
- Most of them contain peptidoglycan in their cell walls
- According to the amount of peptidoglycan present in the cell wall they are classified as Gram positive and Gram negative bacteria
- Most of their cell walls are surrounded by a sticky layer of polysaccharides or proteins called capsule
- Most of them have flagella for motility. Bacterial flagellum differs from eukaryotic flagellum as they are not covered by a plasma membrane and absence of 9+2 structure of microtubules.
- Possess diverse nutritional modes-Autotrophs, heterotrophs
- Posses diverse metabolic modes- obligate aerobes, obligate anaerobes, facultative anaerobes, etc.
- Some are capable of performing nitrogen fixation- e.g. *Rhizobium sp.*, some cyanobacteria
- Rapid reproduction by binary fission. Some perform conjugation as a sexual method.
- Certain bacteria use bacterial chlorophyll as a photosynthetic pigment.

#### **Key Characteristics of Cyanobacteria**

- Prokaryotic organisms
- Photosynthetic
- Most are unicellular and oxygen generating and solitary. But some are linked to form filaments or colonies sheathed in mucous
- Some have the ability of fixing atmospheric nitrogen

**Key characteristics of Domain Archaea**

- They are prokaryotic and unicellular.
- They lack peptidoglycan in their cell walls which are made up of proteins and polysaccharides
- The size of most of them is between 0.5-5  $\mu m$
- They include extreme halophiles and extreme thermophiles
- Some Archaeobacteria live in more moderate environments-Methanogens
- Other species inhabits the anaerobic guts of cattle, termites and other herbivores

**Key characteristics of Domain Eukarya**

- They are Eukaryotic
- Vary in size
- Most of them are multicellular
- Habitats are diverse
- Diverse in nutrition
- Mostly aerobes
- Most of them exhibit sexual reproduction (some protists are only known to reproduce asexually)

**Table 3.1: A comparison of the three domains of life**

	Characteristic	Bacteria	Archea	Eukarya
1	Cellular organization	Prokaryotic	Prokaryotic	Eukaryotic
2	Cell wall composition	Peptidoglycan	Proteins and polysaccharides (lack peptidoglycan)	Cellulose, Hemicellulose, Pectin and Chitin
3	Membrane lipids	Unbranched hydrocarbons	Some branched hydrocarbons	Unbranched hydrocarbons
4	Genetic Composition			
	Histones associated with DNA	Absent	Present in some species	Present
	Circular chromosomes	Present	Present	Absent
	Introns in genes	Very rare	Present in some genes	Present in many genes

5	Protein synthesis			
	RNA polymerase	One kind	Several kinds	Several kinds
	Initiator amino acids for protein synthesis	Formyl-methionine	Methionine	Methionine
6	Response to antibiotics Streptomycin and Chloramphenicol	Growth inhibited	Growth not inhibited	Growth not inhibited
7	Growth at temperatures > 100°C	No	Some species	No
8	Habitats	Diverse habitats	extreme environmental conditions-volcanic pits/ hot springs/ salt marshes etc.	Diverse habitats
9	Examples	Bacteria, cyanobacteria; <i>Nostoc</i> , <i>Anabaena</i> ,, <i>Escherichia coli</i> , <i>Salmonella typhi</i>	Archaeobacteria; <i>Methanococcus</i> <i>Thermococcus</i> ., <i>Helobacteria</i> .	Protists fungis plants and animals

## The diversity of organisms within the kingdom Protista

### Key characteristics of Kingdom Protista

- Most of them are unicellular, although there are some colonial and multi cellular species
- It is a polyphyletic group (originated from more than one ancestor) and an artificial group in classification.
- Found in freshwater, marine and damp soil, some are symbionts.
- Unicellular, colonial or multicellular.
- Some are photoautotrophs, some are heterotrophs and some are mixotrophs (combination of photoautotrophic and heterotrophic nutrition).

***Euglena***

- Unicellular, lack cell wall and pellicle present.
- Chloroplasts are present.
- They have one or two flagella
- They have eye spot
- Contractile vacuole is present
- They have a pocket at one end of the cell from which one or two flagella emerged.

***Paramecium***

- Habitat is freshwater
- Lack cell wall but pellicle is present, unicellular
- Cilia may completely cover the cell surface
- They have two types of nuclei- mega nucleus and micronucleus
- Contractile and food vacuoles are present
- Oral groove is present

***Amoeba***

- Aquatic (marine and freshwater) forms are free living others are parasitic.
- Lack cell walls, unicellular organisms
- They form pseudopodia which are used to locomote and feed
- They do not have definite shape.
- Food vacuoles are present

***Ulva***

- Macroscopic marine forms.
- Cell wall present
- Multicellular thallus differentiated into leaf like blades and root like holdfast.
- Green in colour (green algae)

***Gelidium***

- Marine.
- Cell walls present
- Multicellular thallus with hold fast.
- It is greenish red in colour (red algae)

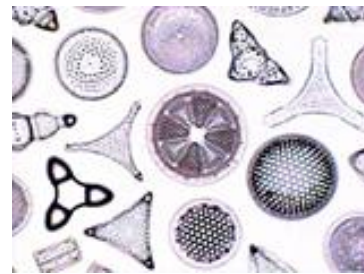
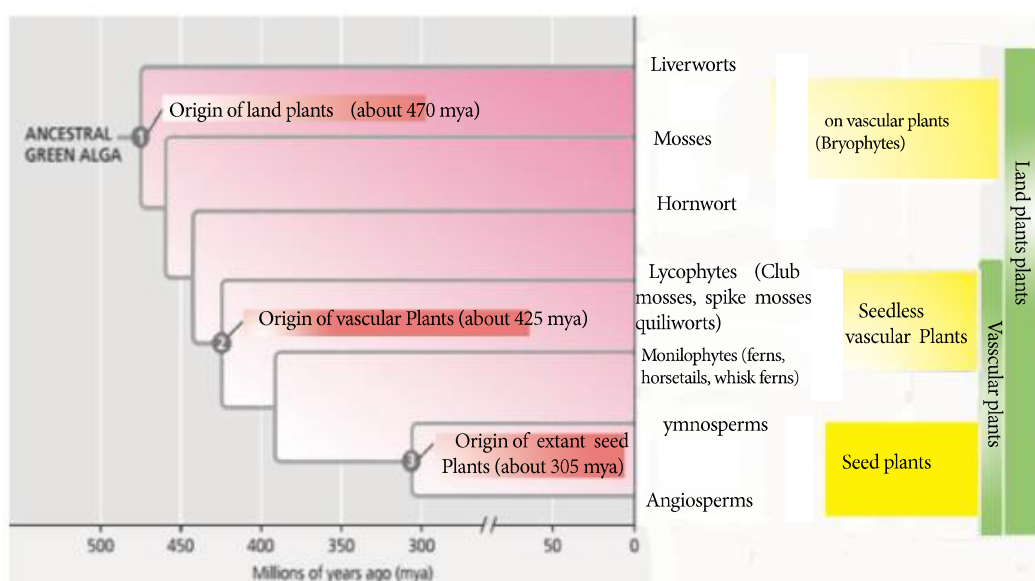


**Sargassum**

- Marine
- Comparatively larger and complex
- Thallus is plant-like; it consists of a root like holdfast, stem like stipe and leaf like blade.
- Multi cellular, thallus is supported by gas filled bulb shape floats.
- Appear in olive green or brown colour (brown algae)

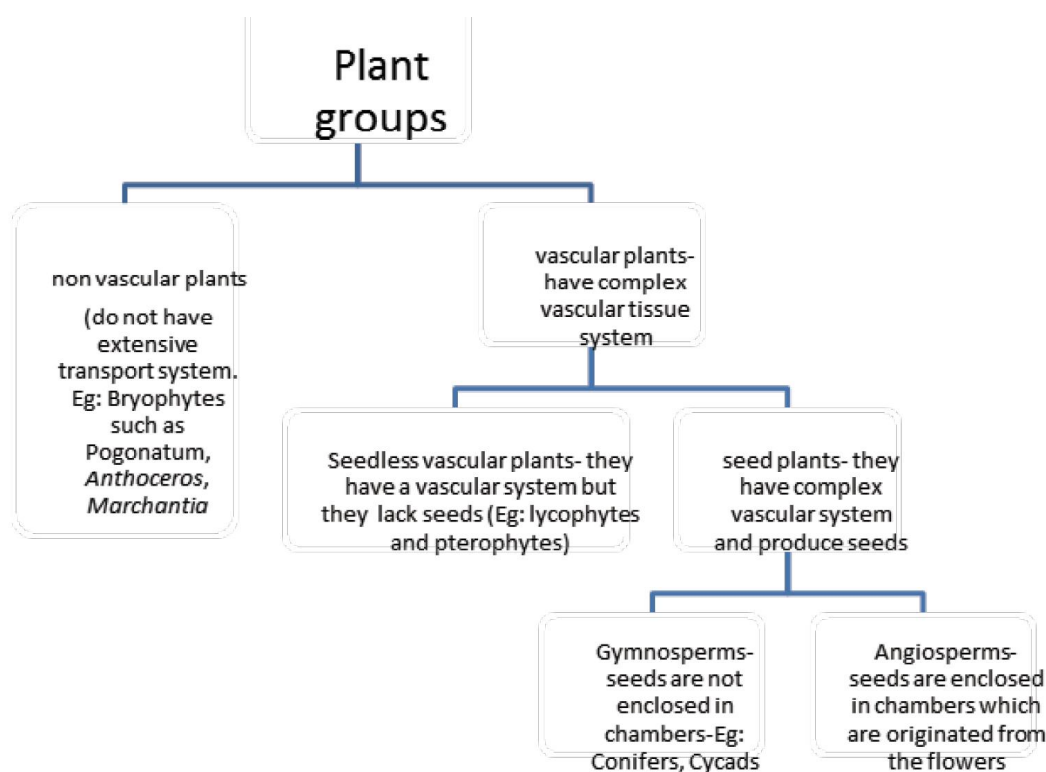
**Diatoms**

- It is aquatic (fresh water and marine)
- Unicellular, having glass like, wall consists of two parts that overlap (presence of silica)
- Highly diverse group regarding the shape and markings in the surface
- Golden brown in colour (golden brown algae)

**The diversity of organisms within the kingdom Plantae****Kingdom Plantae****Evolutionary relationships among major groups of plants****Fig 5.1 Evolutionary relationship of major groups of plants**

It is believed that members of the kingdom Plantae were evolved from a group of chlorophytes/ green algae. Most of them are terrestrial organisms. Chlorophyte algae lack key traits of land plants, walled spores produced in sporangia, multicellular gametangia, dependent embryo and apical meristem. They evolved in the terrestrial environment.

Plant groups can be distinguished based on the presence or absence of an extensive system of vascular tissue. Based on that there are two major groups of plants the can be seen; they are Vascular plants and Non-vascular plants.



### Diversification of Kingdom Plantae

- Non-vascular plants
  - Phylum Bryophyta - Mosses- *Pogonatum*
  - Phylum Hepatophyta- *Marchantia*
  - Phylum- Anthoceroophyta- *Anthoceros*
- Vascular seedless plants
  - Phylum – Lycophyta- *Selaginella*
  - Phylum – Pterophyta- *Nephrolepis*
- Vascular seed plants



- Gymnosperms- Phylum – Cycadophyta (*Cycas sp.*),  
Phylum- Coniferophyta (*Pinus* ), Phylum – Gnetophyta (*Gnetum* )
- Angiosperms- Phylum – Anthophyta (all flowering plants)

### **Non-vascular plants**

One way to distinguish a group of plants is to see whether or not they have an extensive system of vascular tissue that transport water and nutrients throughout the plant body. Most present day plants do have a complex vascular tissue system and therefore, are called vascular plants. Plants that do not have an extensive transport system are described as non vascular plants. Non vascular plants are informally named as Bryophytes.

e.g. *Marchantia*, *Pogonatum*, *Antheroceros*

Bryophytes share some derived traits with vascular plants, but lackin many innovations of vascular plants such as presence of true stems, roots and leaves.

### **Diversity of Bryophytes**

Phylum- Hepatophyta e.g. *Marchantia* (liverworts).

Phylum Anthoceroophyta e.g. *Anthoceros* (hornworts)

Phylum Bryophyta e.g. *Pogonatum* (mosses)

### **Characteristic features of phylum Bryophyta**

e.g. *Pogonatum*

- Especially common in moist terrestrial places.
- Haploid gametophyte is dominant stage of the life cycle, photosynthetic and independent.
- Gametophytes are differentiated into ‘leaves’, ‘stems’ and rhizoids. They have no vascular tissues. Archegonia and antheridia are typically carries on separate female and male gametophyte. Therefore gametophyte is dioecious.
- Male plant produces flagellated sperm which can swim through a film of water for fertilization.
- Sporophytes are usually green and photosynthetic when young. However, they are not independent. They attach to their parental gametophytes and absorb nutrients and water from the female gametophyte.
- Sporophytes have specialized pores called stomata which are also found in all vascular plants.
- They are homosporous.

Vascular plants cover about 93% of the existing plant species. They can be further divided into two groups.

1. Seedless vascular plants
2. Seed plants



### Seedless vascular plants

Seedless vascular plants lack seeds and disperse by means of spores. They are categorized into two groups.

1. Lycophytes
2. Pterophytes

Even though, both pterophytes and lycophytes are seedless plants, pterophytes share a more recent common ancestor with seed plants.

Fossils and living seedless vascular plants provide evidence for plant evolution during Devonian and Carboniferous periods. The ancestors of vascular plants already have had some derived traits of modern vascular plants; however, they lack roots and some other adaptations.

Fossils suggest that, the ancestors of vascular plants had gametophyte and sporophytes that were about equal in size. However among the living vascular plants sporophyte generation is large and more complex. For example in ferns, leafy plants are the gametophytes

### Significant features of seedless vascular plants;

#### 1. Transportation through Xylem and Phloem

Vascular plants have two types of vascular tissues; Xylem and Phloem

Xylem consists of tracheids, fibers and parenchyma cells- conducts water and minerals.

Cell walls of tracheids and fibers are strengthened by the polymer lignin. These tissues permit plants to grow tall. This may facilitate them to obtain a high amount of light for photosynthesis and ease the spore dispersal.

Phloem- this tissue has cells arranged in tubes. They distribute sugars, amino acids and other organic products among different parts of the plant.

#### 2. Evolution of roots

Roots are organs that absorb water and nutrients from the soil. They anchor the plants and allow the shoot system to grow taller. They are to replace the rhizoids seen in bryophytes. Root tissues of living plants resemble stem tissues of the early vascular plants preserved in fossils.

**3. Evolution of leaves-** There are two types of leaves. They are microphylls and megaphylls. Microphylls are single veined and smaller in size while megaphylls are large, flattened with branched veins.

Leaves with branched vascular tissues increase the surface area for efficient photosynthesis (megaphylls).

### Sporophylls and spore variations

Modified leaves that bear sporangia are known as sporophylls. Most seedless vascular plant species produce one type of sporangium and one type of spores. Therefore, they are known as homosporous.

Some plant species produce two types of sporangia and produce two kinds of spores called mega spores and microspores. This condition is known as heterosporous. Mega spores develop into female gametophyte while microspores develop into male gametophyte.

### Phylum Lycophyta

- Lycophytes are terrestrial and some are epiphytes.
- The dominant plant is sporophyte.
- They produce upright stems and ground hugging stems.
- In upright stems small leaves can be found.
- Ground hugging stems produce dichotomously branching roots.
- They have strobili. In many club mosses and spike mosses sporophylls are clustered into club shaped cones/ strobili.
- They are homosporous or heterosporous.

Spike mosses are usually relatively smaller and often grow horizontally.

- All Club mosses are homosporous;  
e.g. *Lycopodium* sp.
- All Spike mosses are heterosporous.  
e.g. *Selaginella*



In some species the tiny gametophyte live above the ground and are photosynthetic. Others live below the ground and are nourished by symbiotic fungi.

### Phylum Pterophyta

- Most sporophytes have rhizome (an underground stem)
- At the tip of the rhizome they produce leaves, called fronds
- Many fronds are highly dissected and feathery.
- All species are homosporous which develop into a bisexual gametophyte.
- Sporophytes are dominant  
e.g. *Nephrolepis*.

**Seed plants**

Vascular plants consist of seeds and are called “seed plants”. They represent the vast majority of living plant species.

Seed plants can be divided into two groups, based on the absence or presence of enclosed chambers in which seeds mature.

1. Gymnosperms
2. Angiosperms



Gymnosperms are “naked seed” plants as their seeds are not enclosed in chambers.

Angiosperms are “seed plant” group accommodating all flowering plants. Angiosperm seeds develop inside chambers called ovaries; which originate within flowers and mature into fruits.

**Significant features of seed plants**

1. Production of seed

A seed consists of an embryo and endosperm. Endosperms supply food to the embryo. This endosperm is surrounded by a protective coat which is known as seed coat. When seeds are mature they can be dispersed through various dispersal methods.

Seeds are key adaptations that help seed plants to become the dominant producers on land and to exhibit the vast plant diversity of today.

**2. Reduced gametophyte**

The evolutionary trend of gametophyte reduction continued further in the vascular plants and led to seed plants. The gametophyte of seed vascular plants is not visible to the naked eye. They are mostly microscopic.

Tiny gametophytes develop from spores and are retained within the sporangia of sporophyte. This arrangement protects the gametophyte from environmental stresses. The moist reproductive tissues of the sporophyte shield the gametophyte from UV radiation and protect them from drying out. This relationship also enables the dependant gametophyte to obtain nutrients from the sporophyte.

**3. Heterospory**

Seed plants are heterosporous (produce both megaspores and microspores). Each megasporangium has a single functional megaspore and each microsporangium contains a large number of microspores.

#### 4. Production of ovules and eggs

Seed plants are unique in retaining the megasporangium within the parent sporophyte. A layer of sporophyte tissue called integument envelops which protects the megasporangium.

The entire structure, containing megasporangium, megaspore and integuments is called an ovule. Inside each ovule female gametophyte develops from a megaspore and produces one or more eggs.

#### 5. Production of pollen and sperms

A microspore develops into pollen grain that consists of a male gametophyte enclosed within the pollen wall. The wall of the pollen is tough as it is made up of the polymer sporopollenin, which protects the pollen grain during pollination. The transfer of pollen grain towards the ovule is called pollination. When a pollen germinates, it gives rise to a pollen tube that discharges sperm (male gametes) into the female gametophyte located within the ovule.

Inside a pollen grain, a sperm producing male gametophyte is present. The sperms of seed plants do not require motility as they are carried directly in to the eggs by pollen tubes. Some gymnosperms retain the ancient flagellated condition, however flagella have been lost in the sperm of most gymnosperms and all angiosperms.

#### Phylum Gnetophyta

e.g. *Gnetum*

- Only gymnosperms have vessels in xylem
- Leaves of gymnosperms look like those of the flowering plants. Their seeds, look like fruits of angiosperms.



#### Phylum Cycadophyta

- They have palm like leaves and large cones
- They have flagellated sperms similar to those of seedless vascular plants  
e.g. *Cycas*



**Phylum Coniferophyta**e.g: *Pinus*

- Large trees are included such as Cyperes and Red woods.
- In conifers two types of spores are produced by separate cones.

**Phylum Anthophyta - Angiosperms**

Presence of flowers -

- Stamens produce microspores and these microspores develop into pollen grains
- These pollen grains contain male gametophyte/ gametes
- Carpels produce megaspores and these megaspores produce female gametophytes/ embryo sac
- Seeds are enclosed within the carpels
- Production of fruits- seeds are protected by fruits which help in their dispersal. This is one of the unique features of phylum Anthophyta. A fruit typically consists of a fertilized ovary and sometimes include other persistent floral parts. After fertilization, the ovary wall thickens and develops into fruit. Ovules develop as seed of the fruit. Thr fruit protects dormant seeds and aid in their dispersal.

**Diversity of Angiosperms**

The flowering plants (angiosperms) are divided into two groups based mainly on the number of cotyledons in their embryo.

These two groups are;

1. Monocotyledons- species with one cotyledons
2. Dicotyledons- species with two cotyledons

**Table 3 .2- Comparison of monocots and Dicots**

<b>Class – Monocotyledoneae</b>	<b>Class – Dicotyledoneae</b>
The embryos have only one cotyledon	Embryos have two cotyledons
Fibrous root system	Tap root system
Parallel veins in leaves	Reticulate veins in leaves
Flower parts are trimerous	Flowers are pentamerous or tetramerous
Perianth present in flowers (No distinct calyx and corolla)	Distinct calyx and corolla present in flowers

Pollen grains are with one opening/ aperture	Pollen grains are with three openings/ apertures
Vascular bundles in the stem do not have cambia and are scattered e.g. grasses, coconut, rice	Vascular bundles in the stem have cambia and arranged in a ring e.g. Rose, shoe flower, cucurbits

## The diversity of organisms within the kingdom Fungi

### Kingdom Fungi

#### Characteristic features of Kingdom Fungi

- Eukaryotic
- Cell walls are made up of chitin a strong but flexible polysaccharide.
- They are absorptive and heterotrophs - many of them secrete extra cellular enzymes which aid in the breaking down of complex molecules into small molecules.
- Different species live as decomposers, parasites or mutualistics.
- Few are unicellular, others forming multicellular filaments called hyphae .
- Septa can be found in hyphae. (division of hyphae into cells by septa – cross walls).
  - Septum has a hole which enables the movement of mitochondria, ribosomes, nuclei etc.
  - Fungi lack septa are known as coenocytic fungi (with many nuclei)
- Fungal hyphae produce mycelium
- Some fungi produce haustoria ( to penetrate and absorb or exchange nutrients between plants and the fungi)
- Multicellular fungi produce mycelia. ( a network of branched hyphae adapted for absorption of nutrition)
- They show sexual and asexual reproduction.
- They produce spores.

#### Characteristic features of Phylum Chytridiomycota

e.g.: *Chytridium*

- Aquatic or terrestrial .
- Some are decomposers while others are parasitic.

- Multicellular or unicellular when multicellular it is coenocytic.
- They produce zoospores which are flagellated.
- Cell walls are made up of chitin.
- Some of them form colonies with hyphae while others exist as single spherical cell.

### **Characteristic features of Phylum Zygomycota**

e.g. *Mucor*, *Rhizopus*

- Most of them are saprotrophs and some of them are parasites or commensals.
- Mycelium is coenocytic and aseptate. Septa found only where reproductive cells are formed.
- Asexual reproduction: Produce sporangia in which genetically identical haploid spores are produced. Also by endospores produced in sporangia.
- Sexual reproduction: A Zygosporangium is produced which is a sturdy structure produced by plasmogamy and karyogamy. Zygosporangium is resistant to unfavorable environmental conditions.
  - o Zygosporangium is a multinucleated structure which is resistant to drying and freezing.
  - o They are metabolically inactive in adverse environmental conditions.
- Zygosporangium produces genetically diverse haploid spores when environmental conditions are favourable.

### **Characteristic features of Phylum Ascomycota**

e.g. *Aspergillus*, *Saccharomyces*, *Penicillium*

- Marine or freshwater or terrestrial
- Parasitic or symbiotic.
- Most of them are decomposers.
- Unicellular or filamentous, multicellular.
- In asexual reproduction conidia are produced at the tip of the conidiophores which are specialized hyphae. (Exospores in clusters or chains)
- In sexual reproduction fusion of sexually differentiated gametangia takes place and produce sac like structure called asci.
- Ascospores are produced within asci. Generally there are eight ascospores are produced in each ascus.
- Most of these fungi produce ascocarps enclosing asci.



**Characteristic features of Phylum Basidiomycota**

e.g. *Agaricus*, Puffballs, Shell fungi

- They are Terrestrial.
- They are major decomposers and some are symbionts.
- Filamentous with septae and dikaryotic.
- Mycelium is the dominant stage of the life cycle.
- They produce fruiting bodies called basidiocarps during sexual reproduction. Produce basidia on the gills of the basidiocarp.
- Produce basidiospores on basidium and exogenous.

**The diversity of organisms within the kingdom Animalia****Kingdom Animalia****Characteristic features of Kingdom Animalia**

- Multicellular
- Heterotrophic eukaryotes- they ingest food and digest them in the body using enzymes
- Cells of the animals are organized into tissues.
- Most of them reproduce by sexually.
- Some show radial symmetry and some others show bilateral symmetry.

**Phylum Cnidaria**

Characteristic features of each example are not necessary

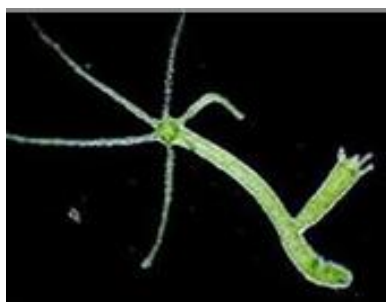
e.g. *Hydra*, Sea anemone, *Obelia*, Corals and Jelly fish



*Obelia*,



*Jelly fish*

*Hydra*

Coral polyp

- Majority of them are marine, except a few fresh water species. Some are macroscopic.
- Simple organization: diploblastic or just 2 body cell layers- an outer layer of ectoderm and inner layer of endoderm sandwiched between these two layers is an acellular layer of mesoglea
- They have a simple gastrovascular cavity which is a sac with a central digestive compartment. This cavity is lined by endodermis with a single opening (mouth) only.
- They show radial symmetry with two body forms polyp and medusa. Polyps are cylindrical forms attached to the substrate by the aboral end of the body. Tentacles are found around the mouth.
- Medusa resembles a flattened mouth down version of the polyps and they are free living.
- Some cnidarians exist only as polyps or only as medusa. Others have both polyp and medusa forms in their lifecycles.
- Tentacles are armed with cnidocytes which function for defense and capturing prey.
- They have nematocysts which contain stinging threads.

### Phylum Platyhelminthes

Characteristic features of each example are not necessary

e.g. *Planaria*, *Taenia*, *Fasciola*

*Planaria**Fasciola*

- Commonly known as flatworms.
- Free living (*Planaria*) or parasitic (flukes and tapeworms).
- They are found in marine, fresh water and in damp terrestrial habitats.
- Body is dorsoventrally flattened. Some have elongated tape like body forms without true segmentation.
- Triploblastic with all three germ layers (ectoderm, mesoderm and endoderm). Signs of cephalization present but are not distinct.
- No body cavities, circulatory, respiratory and skeletal systems. The gaseous exchange is by simple diffusion through body wall.
- Sensory organs are found only in free living examples. Eye spots are found in the head.
- First appearance of little complex nervous and sensory system. A pair of anterior ganglion and two longitudinal nerve cords on central nervous system.
- Appearance of separate organs for excretion: Nitrogenous excretory system consists of protonephridia. These are a network of tubules with ciliated structures called flame bulb. These are used to maintain the osmotic balance.
- They have incomplete digestive system only with mouth without anus. Branched gastrovascular cavity is present for digestion. Some are having eversible pharynx.
- Free living examples have cilia for the locomotion.
- Some show asexual reproduction by regeneration. All are bisexual. Except tape worms (*Taenia*). Others have cross fertilization which is internal. In parasitic forms there are several larval stages, direct development in free living examples without larval stages.

*Taenia*

**Phylum Nematoda** (characteristic features of each example are not necessary)

e.g. round worms, hook worms, pin worms

*round worm**hook worm**pin worm*

- Most of them are free living in marine, few are fresh water and damp soil environments and parasitic in plants and animals.
- They are bilateral symmetrical. Triploblastic with pseudocoelomic. Their body forms are cylindrical with tapered ends. Body size varies from microscopic to macroscopic. They do not show distinct cephalization and segmentation. The sensory papillae are found on the anterior end of the body. Body is covered by tough cuticle and undergoes ecdysis.
- No circulatory and respiratory systems. Gaseous exchange is by simple diffusion through body wall. They have an Alimentary canal.
- Body wall is composed only of longitudinal muscles. They do not have special locomotary structures. Longitudinal muscles in the body wall are involved in locomotion.
- The Sexual reproduction is by internal fertilization. Sexes are separated and females are larger than males.

### Phylum Annelida

Characteristic features of each examples are not necessary

e.g. Earthworms, Leeches and regworms.



*Earth worm*



*Leech*

- They can be marine, freshwater or in damp soil.
- They are segmented worms with cylindrical bodies
- They are Triploblastic.
- Coelom (true body cavity) is present for the first time.
- The first animals to show cephalization.
- Nervous system well developed; dorsal cerebral ganglion, ventral nerve chord, circumenteric connectives.
- Clitellum, Parapodia, setae and suckers are found in some examples. Clitellum is for external fertilization. Parapodia is used for locomotion and respiration. Setae are present for locomotion and suckers for locomotion and ingestion in ecto parasitic forms.

**Phylum Mollusca**

Characteristic features of each examples are not necessary

e.g. Oysters, Clams, Slugs, Snails, Octopus, Squids, Chitons and tusks shells



*Squid*



*Octopus*



Snail



clam



chiton



tusk shell



Oyster

- Majority are marine. Some inhabit freshwater and land. Some are bilateral symmetrical and few are asymmetrical.
- They are soft bodied and non-segmented. Calcareous shell is secreted as a protective exoskeleton. Coelomic.
- Body is divided into three parts:
  - o muscular foot is used for locomotion
  - o visceral mass contains most of the internal organs
  - o mantle is to secrete the shell
- Shell could be internal or external.
- Many molluscs possess radula (a minutely toothed, chitinous ribbon) in the mouth for feeding.
- Most molluscs have separated sexes and their gonads are located in visceral mass.

### Phylum Arthropoda

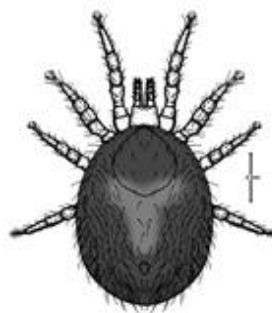
Characteristic features of each examples are not necessary  
e.g. Insects, Spiders, Prawns, Crabs, Scorpions, Ticks, Mites, Millipedes and Centipedes.



Spider



Scorpion



Mite



Tick



Centipede



Millepede

- One of the most successful animal groups on earth with the highest number of species. They live everywhere – air, water, soil
- They have segmented bodies with “jointed legs”
- They have a chitinous exoskeleton (skeleton on the outside) Because of exoskeleton these animals can’t grow continuously and needs periodic molting
- The nervous system is well developed with primitive dorsal brain.
- The nerve cord is solid, segmented and ventrally located.
- They have many and varied sense organs.
- They have an open blood circulatory system; Blood is pumped by a heart into the body cavities (haemocoel), where tissues are surrounded by the blood. No capillaries.
- Respiration
  - In aquatic animals- Gills
  - In terrestrial animals- Tracheal system of chitinous tubes
  - In arachnids - Book lungs
- Excretion is by Malphigian tubules They excrete uric acids
- Reproduction: Sexes separate [Dioecious]

### Phylum Echinodermata

Characteristic features of each examples are not necessary

e.g. sea stars, brittle stars, sea lily, feather star, sea cucumber, sea urchins and sand dollars



Sea star



Sea lily



Brittle star



Sand dollar



Sea cucumber

- They are exclusively marine. Triploblastic and coelomic, slow moving or sessile.
- Adults are penta radial symmetrical without head and segmentation.
- Deuterostomes.
- Thin epidermis covers the endoskeleton of hard calcareous plates.
- Water vascular system is a network by hydraulic canals branching into tube feet which function in locomotion and feeding.
- Digestive system is usually complete, but the mouth is on the underside and the anus on the top surface of the animal.
- Circulatory system is reduced and closed without a heart. Sexes are separated with external fertilization. Larval forms are bilaterally symmetrical.
- Well developed nervous system. Intelligent animals.

## **The characteristic features to study organisms belonging to phylum Chordata**

### **Phylum Chordata**

#### **Characteristic features of Phylum Chordata**

- Longitudinal, flexible rod called notochord located between digestive tube and nerve cord. It is extending from anterior to posterior providing support in at least embryonic stage.
- Dorsal, hollow, single nerve cord located dorsal to the notochord.
- In all chordate embryos there are slits or clefts in pairs either side of pharynx (pharyngeal slits) that opens to the outside of body. In terrestrial, adult chordates it disappears and remains in the aquatic adults and larval forms of terrestrial chordates as respiratory structures.
- Muscular tail that extends posterior to the anus present in the embryonic stages. In some terrestrial adult it is reduced.

(Characteristic features of each examples of following classes are not necessary)



**Characteristic features of class Chondrichthyes**

e.g. Skates, Sharks

- All are aquatic
- Skeleton composed predominantly of cartilage
- Fins for locomotion
- Caudal fin is heterocercal.
- Gills without operculum.
- Body is covered with placoid scales.
- Eggs are fertilized internally. Some are ovoviviparous and others are oviparous or viviparous.
- Reproductive tract, excretory duct and digestive tract empty into the cloaca, a common chamber that has a single opening to the outside.

**Characteristic features of Class Osteichthyes**

- All are aquatic
- Having a skeleton composed of bones.
- Gills are covered by a bony flap called operculum.
- Swim bladder for control the buoyancy.
- Caudal fin is homocercal.
- Body is covered by flatten bony scales called ctenoid and cycloid scales.
- Most are fertilized externally some have internal fertilization.
- Most species are oviparous.

e.g. Carp, Tuna,

**Characteristic features of Amphibia**

- First animals to invade land but need water to complete life cycle, live in both water and on land.
- They are found only on land or fresh waters. No marine species.
- First species to poses limbs, body is somewhat elevated by these limbs to help locomotion in terrestrial environment.
- Some are limbless but some are tetrapods.
- Ectothermic- changes body temperature according to environmental temperature. This restricts metabolism.
- Body is covered with thin, moist skin. No scales. Sensitive to environmental changes.
- Nictitating membrane covers the eye and tympanic membrane is found behind the eye.
- Most amphibians show external fertilization. Eggs without shells.

e.g. Toad, Frog, *Ichthyophis*

**Characteristic features of Reptilia**

- They are the first animal to live a complete terrestrial life.
- Possess limbs for locomotion and digits.
- Body is covered with keratinized scales to prevent from desiccation and abrasion.
- Posses lungs for aerial respiration.
- They are ectothermic (cold blooded)
- Live in terrestrial and aquatic habitats.
- Internal fertilization. They lay shelled eggs (calcareous) on land.

e.g. Lizards, Snakes, Turtles, Crocodiles and Alligators

**Characteristic features of Aves**

- Body is covered by keratinized feathers.
- Hind limbs are converted to flight.
- Many adaptations to help flying: light body, wings, bones with air cavities, high metabolism, restrictions in body size
- They are having a beak without teeth.
- They are endothermic.
- Birds have colour vision and excellent eye sight.
- Internal fertilization, lay shelled eggs

e.g. Crow, Parrot, Humming birds, Eagles etc.

**Characteristic features of Mammalia**

- Nourish young by producing milk with mammary glands.
- Body covered with hair for insulation.
- They are endothermic group of animals and most of them have high metabolic rate.
- They have differentiated teeth.
- They have an efficient respiratory system with lungs.
- A complete circulatory systems and a four chambered heart.
- Muscular diaphragm is found to help respiration.
- They have a larger brain with compared to the other group of vertebrates. Very intelligent animals. Learning skills and a good memory.
- Different methods of communication.
- Show relatively long periods of parental care.

e.g. Bat, whales, monkeys, cows

**04****Plant form and function****Structure, Growth and Development of Plants**

The main focus of this unit is on structure, growth and development of vascular plants.

Plants consist of a root system and a shoot system and roots and shoots grow at their tips, which are with meristematic properties and called as apices, buds or meristems.

**Types of plant tissues, structure- function relationship**

A Tissue is a group of one or more cell types which carries out specialized function(s).

**Meristems, locations and role in plant growth**

Plants have undifferentiated tissues called meristems, consisting of cells which constantly divide under suitable conditions and produce new cells. Some of these cells then elongate and differentiate to produce new tissues of the plant body and others remain as meristems. Meristems may have dormant periods. Due to the action of meristem new cells are added. Subsequently these cells get differentiated and therefore plant growth occurs by making new plant tissues.

**Characteristics of meristematic cells**

All cells in the meristems have common characteristics. They;

- are living cells
- are isodiametric (roughly spherical)
- are structurally and functionally undifferentiated
- have a central nucleus
- have a dense cytoplasm
- have ability to multiply

In meristem there are three overlapping zones of cells consisting of cells at successive stages of

- cell division
- cell elongation and
- differentiation

There are three types of meristems. They are;

1. apical meristems
2. lateral meristems
3. intercalary meristems

### **Apical meristems**

These meristems are located at root tips and shoot tips. They add new cells that enable increase in length. This process is known as primary growth.

### **Lateral meristems**

Vascular cambium and cork cambium are lateral meristems. They are found in woody plants and involve in the secondary growth in increasing circumference of roots and stems. The vascular cambium produces secondary xylem and secondary phloem. The cork cambium produces thick and tough periderm, replacing epidermis.

### **Intercalary meristems**

Some monocots such as grasses show meristematic activity at the bases of stems and leaves (nodes). These are known as intercalary meristems. They allow rapid regrowth in damaged leaves.

### **Primary growth of roots**

Elongation of root due to the activity of primary meristems located on root apex is called primary growth of the root.

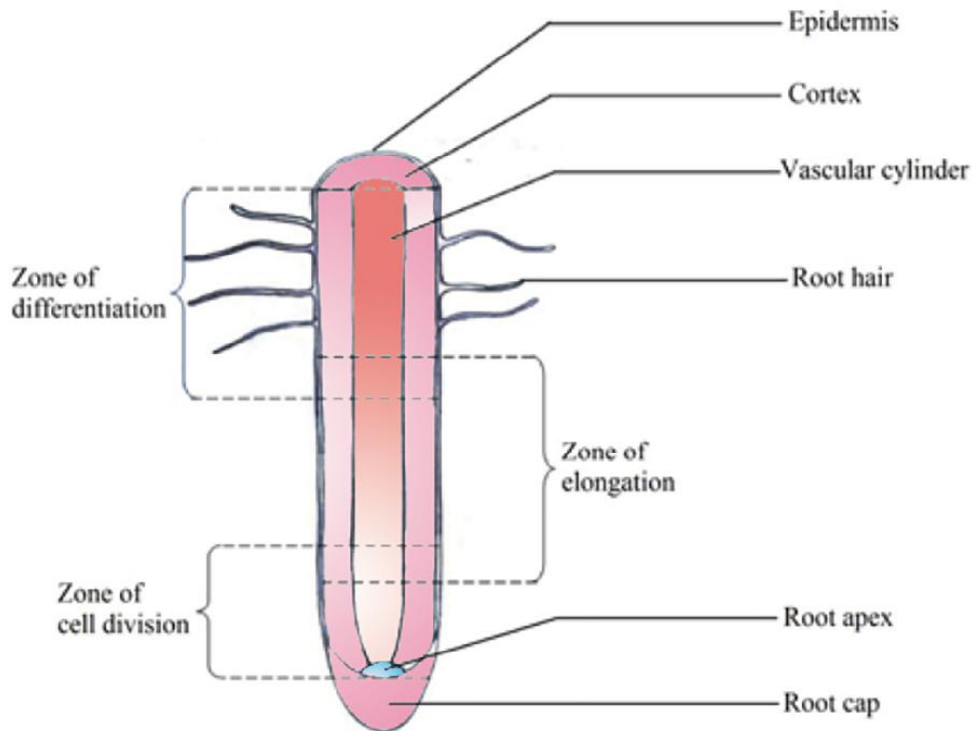
During the growth three processes take place.

- i. Cell division - due to mitotic division.
- ii. Cell elongation
- iii. Cell maturation - due to differentiation.

These stages are found in three overlapping regions starting from meristems.

The zone of cell division includes the root apical meristem and its derivatives. In this region, new cells are produced to both sides. Cells produced outward to the apical meristem are differentiated to form root cap which prevents damaging the root apical meristem from friction when grows through soil.

Cells produced inward to the meristem undergo elongation, in the zone of cell elongation. Root cells elongate, sometimes to more than ten times their original length. Hence the root is pushed forward through soil.



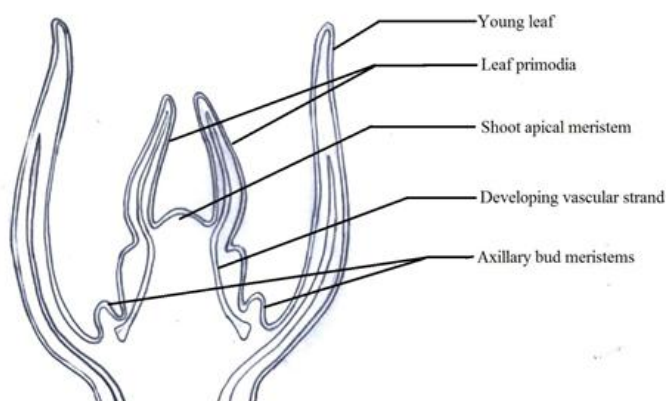
**Fig. 4.1** The different zones of the root (zone of differentiation, Zone of elongation and zone of cell divisions)

In the zone of maturation, the cells begin specializing in structure and function where cells complete their differentiation and become functionally mature. Primary structure of the root is formed as a result of primary growth.

### Primary growth of the shoot:

Elongation of shoot is due to the activity of primary meristem located in shoot apex, and is called primary growth of the shoot.

A shoot apical meristem is a dome-shaped mass of dividing cells located at the shoot tip.



**fig 4.2 .The Ls of the Shoot**

Leaves develop from leaf primordia, finger-like projections along the sides of the apical meristems. Normally these primordia cover the shoot apical meristem.

Shoot apical meristem produces new cells only towards the stem, due to mitosis. After cell elongation, cell differentiation takes place.

Then the primary tissues of the stem are formed due to cell differentiation. Therefore, the height of the stem is increased due to primary growth.

**Table 4.1 Differences between shoot apex and root apex**

<b>Shoot apex</b>	<b>Root apex</b>
Found at tips of shoot	Found at the tip of the root
Protected by leaf primordia	Protected by root cap
Produces new cells only inwards	Produce new cells both sides outwards and inwards

### **Plant tissue systems**

The new cells originating from the meristems are differentiated to perform specialized functions and form a plant tissue system. During differentiation process, they undergo changes in cytoplasm, organelles and cell wall. Therefore, several types of plant cells can be recognized according to their structure and function.

A tissue consists of group of one or more cell types which carries out specialized function(s).

Vascular plants have three main tissue systems. They are;

1. dermal tissue systems
2. ground tissue systems
3. vascular tissue systems

### **Dermal tissue system**

This is the outer protective covering of plants.

e.g. Epidermis

- Protective layer in the stems and roots of the primary plant body and leaves
- Tightly packed single cell layer
- Normally covered by a cuticle which is a waxy epidermal coating in aerial parts
- Specialized cells such as guard cells, trichomes and root hairs are also found in epidermis

### **Functions of epidermis:**

- Defense against physical damage and pathogens
- Cuticle helps to prevent water loss

- Root hairs involve in absorption of water and mineral ions
- Guard cells help gaseous exchange
- Trichomes (epidermal outgrowths such as hairs and glands) ;
  - o hair like trichomes reduce water loss, shiny hairs reflect excess light
  - o Some trichomes secrete chemicals involved in defense against insects/ pathogens/ herbivores,

Epidermis in older regions of stems and roots is replaced by a protective layer called periderm after the secondary growth

### Ground tissue system

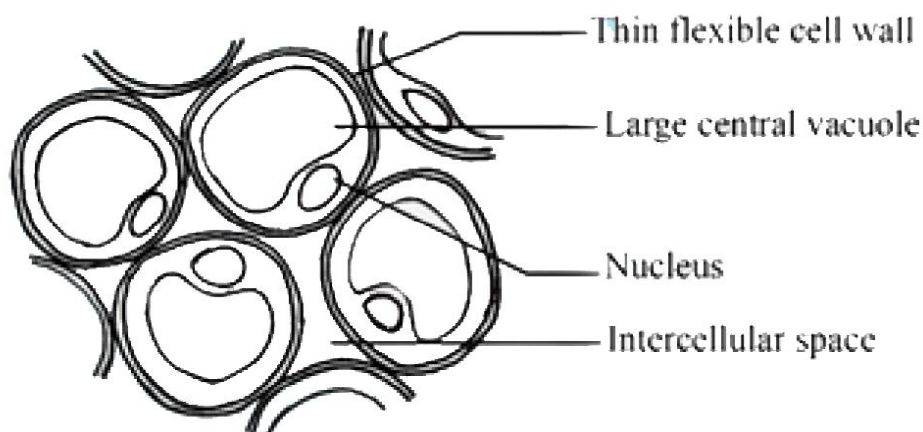
Ground tissue fills the gap between dermal tissue and vascular tissue, mainly consists of cortex (outer to vascular tissue) and pith (inner to vascular tissue). The ground tissue includes cells specialized for functions such as storage, photosynthesis, support and short distance transport.

Three main types of cells are present in ground tissue. They are;

1. parenchyma cells
2. collenchyma cells
3. sclerenchyma cells

### Parenchyma cells

- Living even at functional maturity
- Mature cells have primary cell walls which are relatively thin, flexible and most of the cells lack secondary walls
- They have a large central vacuole



*Fig 4.3 Diagram of General Parenchyma cells*

**Functions**

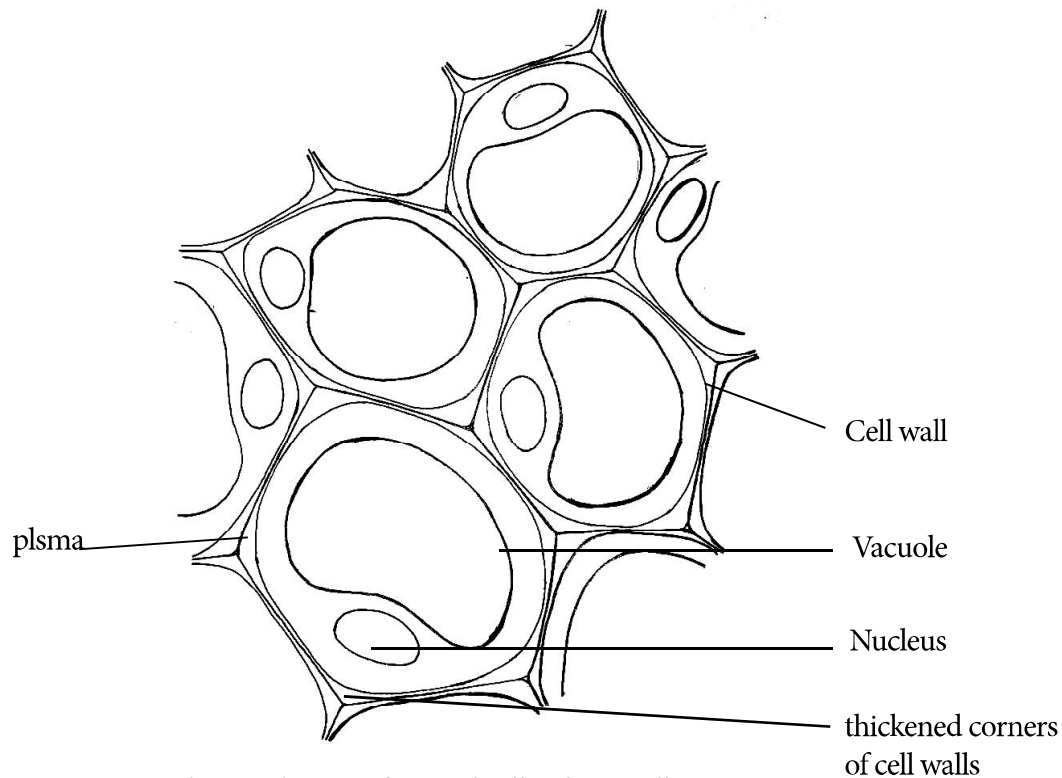
- Perform most of the metabolic functions of the plants.  
e.g. synthesis of various organic products
- Storage-  
e.g. some cells in root and stems contain plastids (leucoplasts) which store starch.
- Most of the parenchyma cells retain the ability to divide and differentiate under suitable conditions. This ability is important in wound repair. These abilities also make it possible to multiply and differentiate cells even from a single parenchyma cell in tissue culture practices.

**Collenchyma cells**

- They are generally elongated
- They have thicker primary walls than parenchyma cells
- Their walls are unevenly thickened
- Young stems and petioles often have strands of collenchyma cells just below the epidermis
- Even at functional maturity they are living, flexible and elongating with stems and leaves they support

**Functions**

- Give mechanical support to leaves and stems without restraining growth



*Fig 4.4 Diagram of general collenchyma cells*



**Sclerenchyma cells**

- Secondary cell walls are produced after cell elongation
- They have secondary cell walls thickened by large amount of lignin
- They are dead cells at maturity

There are two types of sclerenchyma cells;

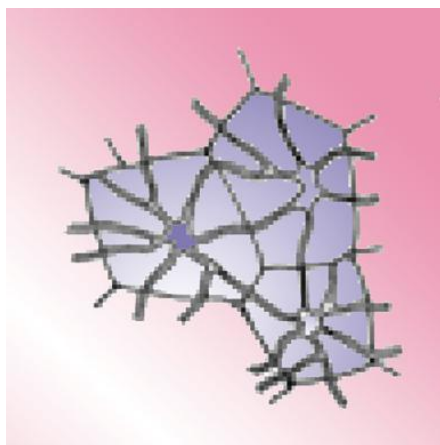
1. sclereids
2. fibers

**Sclereids** are shorter and wider than fibers and irregular in shape. They have very thick lignified secondary cell walls. They are found in places where growth has stopped e.g. nut shells, seed coats and flesh of coarse fruit.

**Fibers** are usually grouped in strands. They are long, slender and tapered. Used commercially to obtain fibers. e.g: coconut husk fiber, hemp fibers

**Functions**

Sclereids and fibers are specialized to provide support and strength.



*Fig 4.5 : Diagram of T.s of sclereids*

**Vascular tissues- Xylem and phloem****Xylem tissue**

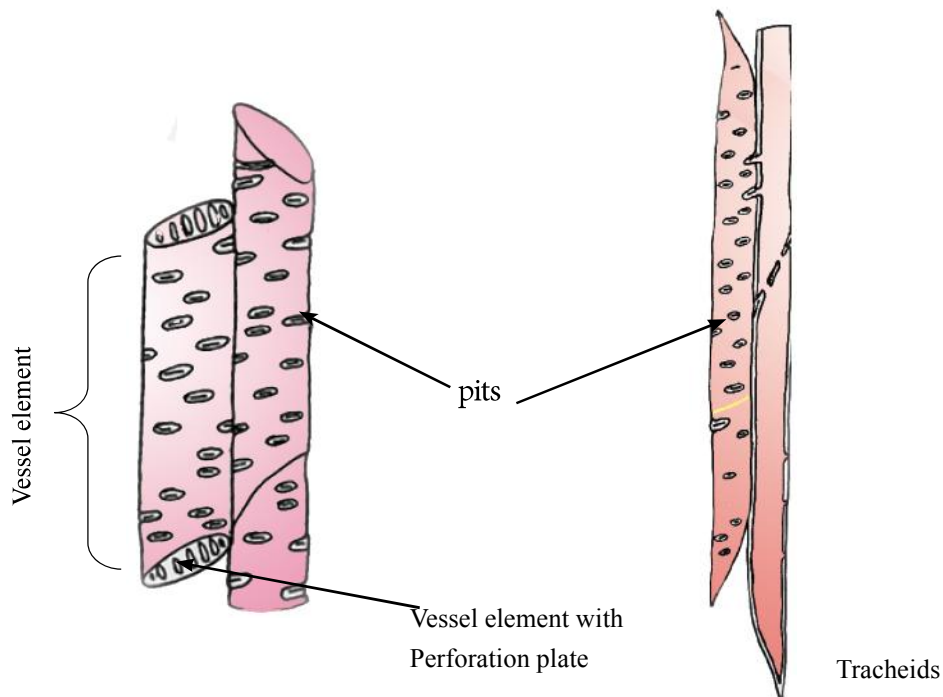
- It consists of vessel elements, tracheids, fibers and parenchyma cells in angiosperms and some of the gymnosperms.
- Vessel elements and tracheids mainly conduct water.
- They are dead at functional maturity.
- Fibers give mechanical strength.
- Parenchyma functions in storage and in radial transportation.

### Vessel elements

- In all angiosperms and some gymnosperms, contain vessel elements
- They are cylindrical and long.
- They are wider, shorter and have thinner walls than tracheids
- Secondary walls are thickened by lignin
- They provide support to prevent collapse under tension of water transport
- Perforation plates are present at end walls of vessel elements. Other walls are interrupted by pits
- They form xylem vessel by aligning end to end with perforation plates
- Water flows freely through perforation plates

### Tracheids

- Found in all vascular plants
- Long, thin cells with tapering ends
- Secondary walls are thickened with lignin and often interrupted by pits
- Water moves from end to end through pits
- Thickening by lignin provides support to prevent collapse under water transport



*Fig 4.6 Diagram of L.S of vessel element and tracheids*

**Phloem tissue**

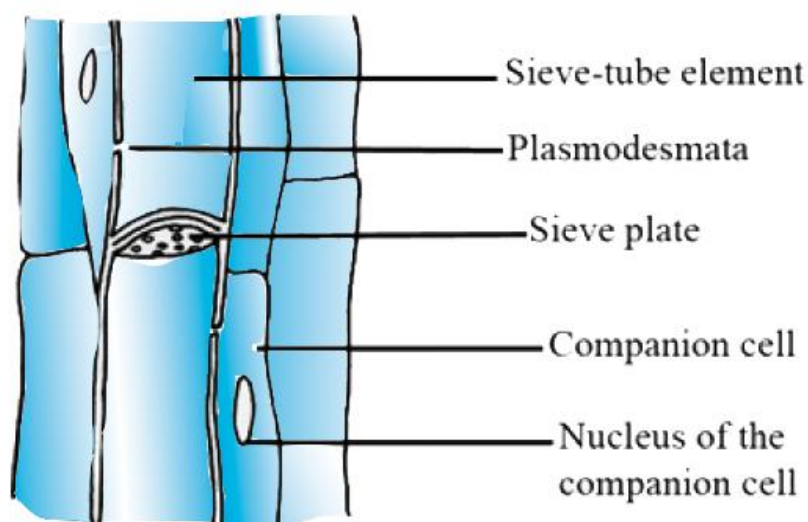
- It consists of sieve tube elements, companion cells, parenchyma cells and fibers in angiosperms
- Except fibers other phloem cells are living cells
- In seedless vascular plants and gymnosperms sieve tube elements and companion cells are absent. Instead of sieve tube elements, long narrow cells called sieve cells are present in these plants.

**Sieve tube elements**

- Sieve tube elements lack nucleus, ribosomes, a distinct vacuole, and cytoskeletal elements-
- cytoplasm reduced into a thin peripheral layer.
- Absence of these allow passing of nutrients more freely
- Chains of sieve tube elements are aligned to form sieve tubes
- The end walls between sieve tube elements contain porous plate called sieve plate.
- Sieve plate allows movement of fluid from one sieve element to the next.

**Companion cells**

- They are non-conducting cells.
- Found alongside in each sieve tube element and connects with sieve tube element by numerous plasmodesmata
- Nucleus and ribosomes of these cells also serve to adjacent sieve tube element
- Some companion cells in leaves help in phloem loading and in other organs unloading



*Fig -4.7 Longitudinal view of sieve tube elements and companion cells*

## Growth and development process of a plant

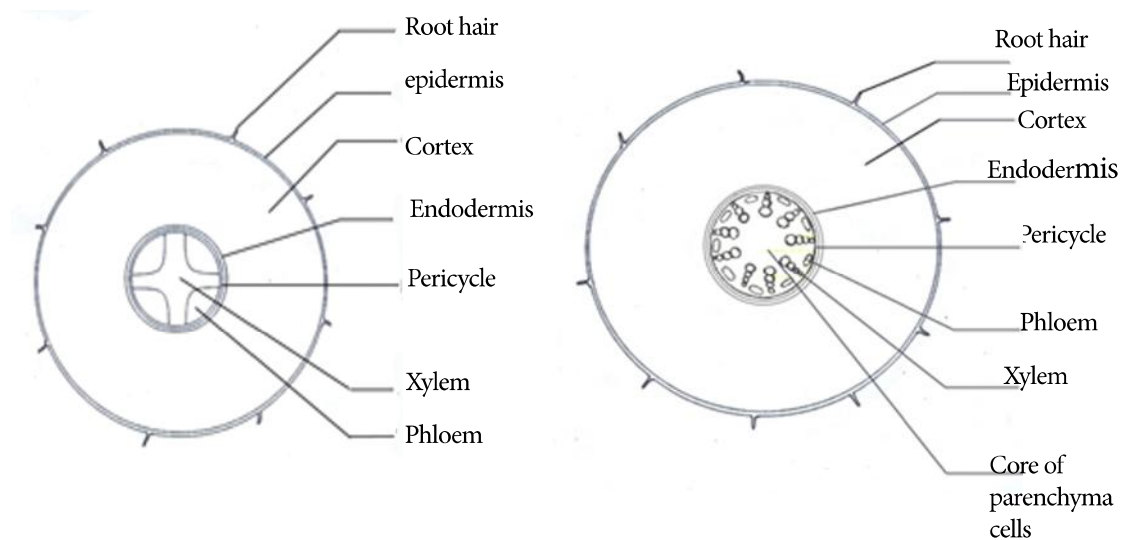
### Plant growth

Growth involves irreversible increase of dry mass associated with the development of an organism. Often it is associated with increase of cell number as a result of producing more cells from the meristem accompanied by cell elongation.

Plants continue growth throughout the life known as indeterminate growth.

### Primary structure root

Apart of the distribution pattern of xylem and phloem tissue structures of both monocot and dicot roots are more or less similar.

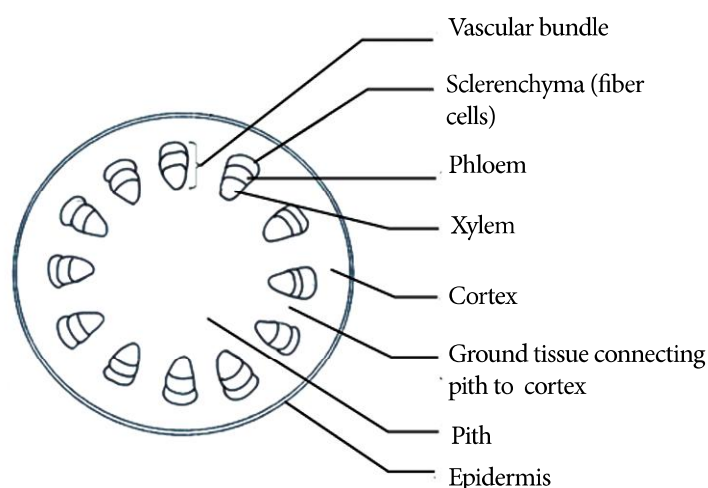


**Fig- 4.8 Primary structure of typical Dicot and Primary structure of typical monocot root**

- Outermost cell layer is epidermis. Cells have unicellular outgrowths called root hairs. Epidermis protects inner parts while root hairs involve in the absorption of water and minerals.
- Between epidermis and vascular cylinder there is a ground tissue known as cortex which is made up of mostly parenchyma cells with intercellular spaces.
- Cortex mainly stores carbohydrates, and also transports water and minerals towards the endodermis.
- Innermost single cell layer of the cortex is the endodermis.
- Endodermis contains a suberin belt called casparian strip and no inter-cellular spaces. Therefore, it blocks cortical apoplast from the vascular apoplast.
- Interior to endodermis there is a pericycle containing two or three parenchyma cell layers. These cells in dicot roots have meristematic function and involve in the formation of lateral roots and secondary growth of the root.

- Inner to pericycle there is vascular tissues as a solid core. Xylem can be found in the middle and it is star shaped in a cross section of a dicot root. Phloem is located in the groove between the arms of xylem.
- In monocot roots, vascular tissue consists of a central core of parenchyma cells surrounded by a ring of alternating xylem and phloem. Pericycle in monocot roots is not meristematic

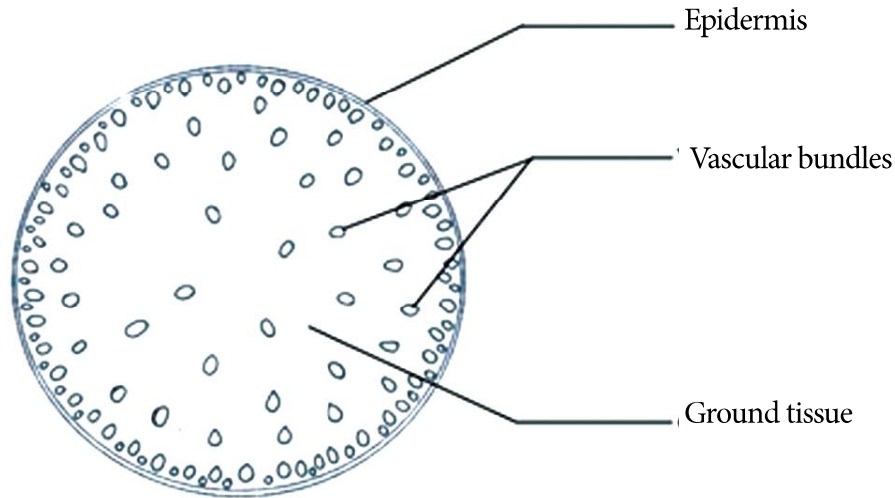
### Primary structure of dicotyledonous plant stem :



**Fig 4.9 Primary structure of T.S of dictolyledonous plant stem**

- The outermost epidermal cell layer protects inner parts from desiccation and infections. The epidermis is interrupted by pores called stomata.
- Interior to epidermis is cortex mostly containing parenchyma cells.
- Collenchyma cells may also be present just beneath the epidermis to provide strength.
- Sclerenchyma such as fibers are also present in the cortex to provide additional support.
- Vascular bundles arranged as a ring. Vascular bundle contains primary phloem towards cortex primary xylem towards pith and in-between a cambium tissue.
- Outside vascular bundle, there is a cluster of sclerenchyma cell.
- Inner to vascular bundles large pith which is also made up of parenchyma cells can be found.
- Lateral shoots develop from axillary buds

### Primary structure of the monocotyledonous stem:



*Fig :4.10 Primary structure of cross section of typical monocot stem*

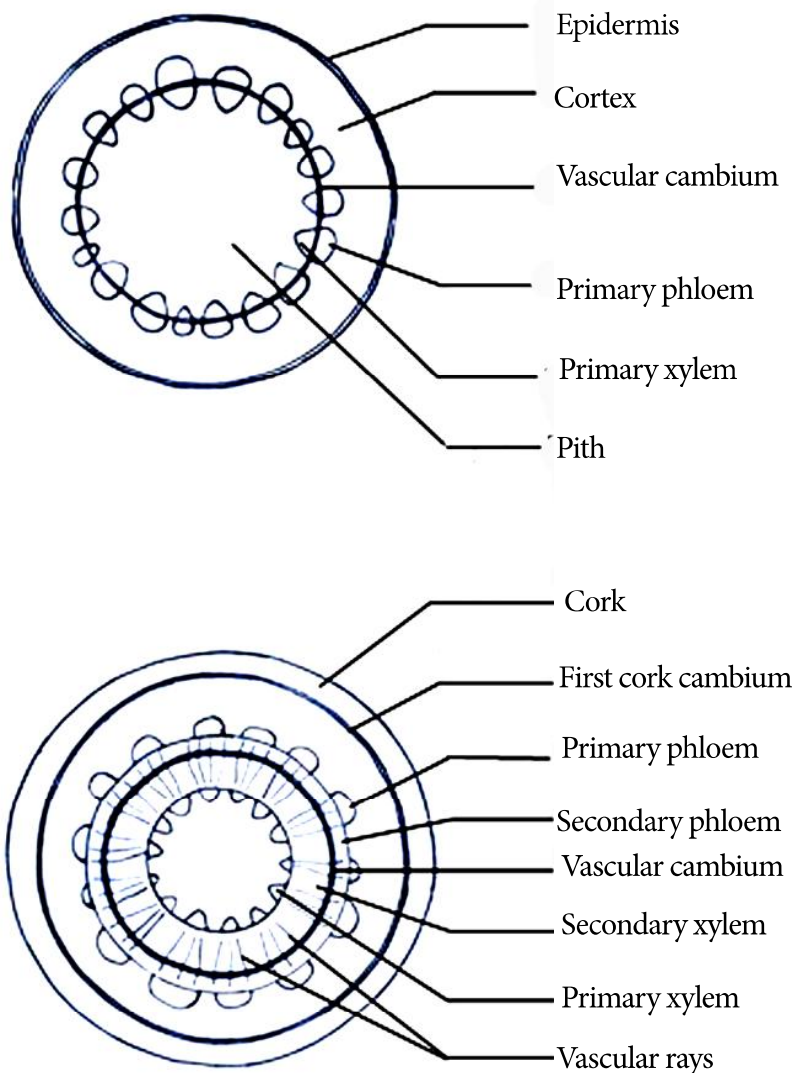
- Ground tissue of monocot shoot is not differentiated into cortex and pith
- The vascular bundles are scattered throughout the ground tissue in most monocot stems.
- Each vascular bundle is surrounded by sclerenchyma. It consists of a xylem tissue and a phloem tissue but no cambium inbetween xylem and phloem.

### Secondary growth :

- Increase in the diameter of stems and roots in plants due to the new cells produced by lateral meristems is called secondary growth.
- This occurs in stems and roots of woody perennial plants including, all gymnosperms species and many dicot species.
- Lateral meristems, namely vascular cambium and cork cambium produce cells and tissues in the secondary growth.
- The vascular cambium adds secondary xylem (wood) towards primary xylem and secondary phloem towards primary phloem, increasing vascular flow and support for the shoots.
- The cork cambium produces tough thick covering consisting mainly of wax impregnated cells that protect the stem from water loss and from invasion of insects, bacteria and fungi.
- In woody plants, primary growth and secondary growth occur simultaneously. As the primary growth adds new cells and lengthens stems and roots in the younger regions of a plant, secondary growth increases the diameter of stems and roots in older regions where. primary growth has ceased.

- Secondary vascular tissue is produced by the action of vascular cambium.
- In a typical woody stem, the vascular cambium consists of a continuous cylinder of undifferentiated cells of often only a single cell layer in thickness, located outside the pith and primary xylem and to the inside of the cortex and primary phloem.
- In a typical woody root, the vascular cambium forms laterally exterior to the primary xylem and interior to the primary phloem and pericycle.
- As these meristematic cells divide they increase circumference of the vascular cambium and also add secondary xylem to the inside of the cambium and secondary phloem to the outside.
- Viewed in a cross section, the vascular cambium appears as a ring of initials.
- Some initials are elongated and are oriented with their long axis parallel to the axis of stem or root.
- They produce cells such as tracheids, vessel elements, parenchyma and fibers of the xylem, as well as sieve-tube elements companion cells, phloem fibers and phloem parenchyma.
- The other initials are shorter and oriented perpendicular to the axis of the stem or root.
- They produce vascular rays—mostly parenchyma cells that connect secondary xylem and phloem, store carbohydrates and aid in wound repairing.
- As the secondary growth continues over many years, layers of secondary xylem (wood) accumulate.
- The walls of the secondary xylem cells are heavily lignified and account for the hardness and strength of wood.
- During early stages of secondary growth, the epidermis is pushed outwards, causing it to split, dry and fall off the stem or root.
- It is replaced by two tissues produced by cork cambium, a cylinder of dividing cells that arises in the outer layer of cortex in stems and in the outer layer of pericycle in the roots.
- Cork cambium produces cork cells to exterior.
- Cork cambium and tissues it produces are collectively called periderm.
- As the cork cells mature, they deposit a waxy, hydrophobic material called suberin in their walls and they become dead cells.
- The cork tissues function as a barrier that helps protect the stem or root from water loss, physical damages and pathogens.
- Each cork cambium and the tissues it produces comprise a layer of periderm which is impermeable to water and gasses.

- For gaseous exchange small pores are present in the periderm known as lenticels which are formed by loosely arranged cork cells. They appear as horizontal slits.
- Further growth of stem or root breaks the layer of cork cambium and it lacks its meristematic activity and its cells become cork cells
- A new cork cambium is initiated inside which will produce a new layer of periderm.
- As new cells are added, the outer regions of cork will crack and peel off in many tree trunks.
- Due to the tissue layers produced by vascular cambium and cork cambium, girth of the stem or root increases in secondary growth.
- Bark is all tissues out of the vascular cambium (cork is commonly and incorrectly referred to as bark). Its main components are secondary phloem and periderm.



**Fig. 4.11-** The process of secondary growth of dicot woody plant



**Heart Wood and Sap wood:**

- As a woody plant ages, the older layers of secondary xylem no longer transport water and minerals.
- These layers are called heartwood because they are close to the centre of the stem or root.
- The newest outer layers of secondary xylem, still transport xylem sap are known as sapwood.
- The heartwood is generally darker than sapwood because of resins and other compounds that permeate the cell cavities and help protect the core of the tree from fungi and wood-boring insects.
- Only the young secondary phloem functions in phloem translocation and old secondary phloem is sloughed off.

**Hard wood and soft wood**

- Hard wood is the secondary xylem of dicot angiosperms while wood of gymnosperms are named soft wood
- Xylem vessels are absent in soft wood

**Growth rings:**

- The thickness of secondary xylem and the lumen of vessels are larger in periods of warm and wet seasons compared to other growth season of the year. These differences are visible in a cross section as lighter and darker rings. These are referred as growth rings.
- In temperate regions, wood that develops early in spring is known as spring wood. This xylem tissue consists of xylem vessels with large lumens and thin walls. This structure maximizes delivery of water to new leaves.
- The wood produced during rest of the growing season is called summer wood. These xylem tissues consist of xylem vessels with thick walls and small lumen, do not transport much water but provide more support.
- These two woods collectively known as an annual ring. A year's growth appears as distinct ring in the cross section of most tree trunks and roots. Therefore age of the tree can be estimated by counting annual rings in trees growing in temperate regions.

**Shoot, architecture and light capture**

- Length of the stem and branching pattern are designed to capture maximum light.
- Plants grow tall to avoid shading from neighboring plants.

**Stem**

- Most tall plants have thick stem with strong mechanical support.
- Woody plants undergo secondary growth thereby make their tall stem stronger.
- Vines rely on other objects to reach higher levels to capture more light.

**Branching pattern**

- There is a variety in branching pattern.
- Some plants are unbranched and still others are well branched.
- This variation in branching pattern enables the plant to absorb maximum light in the ecological niche it occupies.

**Leaves****Leaf size**

- Size of the leaf vary, based on the place where the plant grows.
- Largest leaves are found in plants growing in rain forests.
- Smallest leaves are found in plant species inhabiting dry or very cold environments.

**Phyllotaxy**

- This is the arrangement of leaves on the stem.
- The arrangement may be one leaf, two leaves or several leaves per node.
- Phyllotaxy helps the plant to capture maximum sunlight.

**Leaf orientation**

- Leaves may be horizontally oriented.
- They capture light efficiently in low light conditions.
- Some plants have vertically arranged leaves. e.g. Grasses
- This is to avoid the possible damage caused by exposure of leaf to the over intense light. When leaves are nearly vertical, light rays are parallel to the leaf surfaces, so no leaves receive too much of light.

**Process of Gaseous Exchange in Plants****Anatomy of typical dicot and monocot leaves**

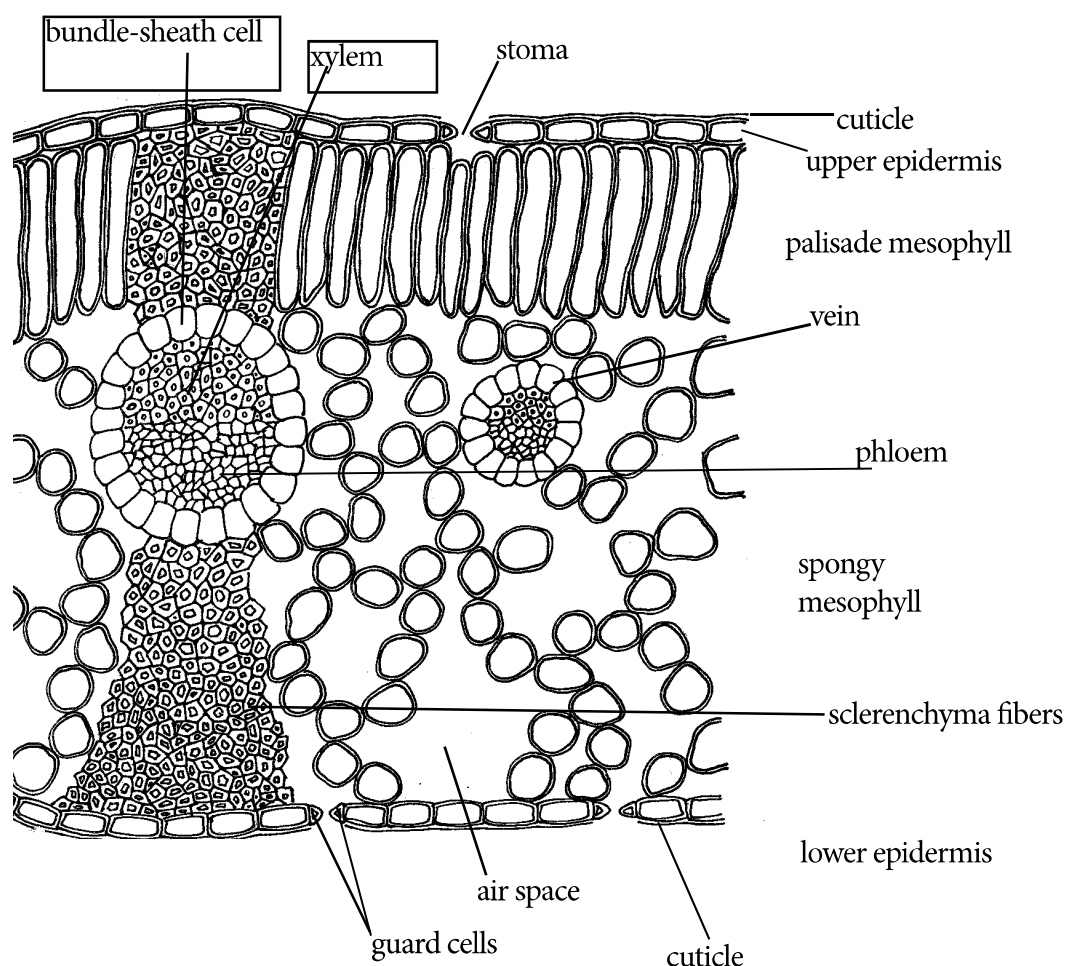
In most vascular plants, leaves are the main photosynthetic organs. The exchange of gases occurs through stomata in the upper and lower epidermis. Epidermis is usually a single cell layer. In between the upper and lower epidermis, there is a ground tissue called the mesophyll. This tissue consists of parenchyma cells, specialized for photosynthesis.

In dicot leaves, stomata are, mainly found in the lower epidermis. The mesophyll consists of two distinct layers called palisade and spongy. Palisade mesophyll consists of elongated cells that are arranged in one or more layers. This can be found in the upper part of the leaf, just beneath the upper epidermis.

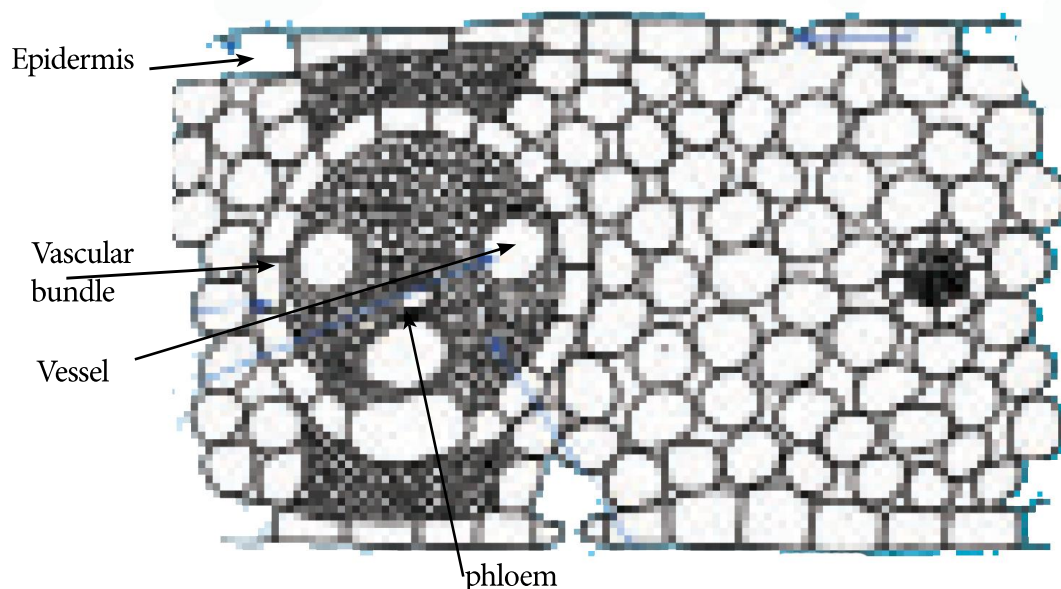
The spongy mesophyll can be found between the palisade layer and lower epidermis. They are loosely arranged with many air spaces. Spongy mesophyll cells have less chloroplasts than in palisade mesophyll cells.

The vascular tissue of the leaf is continuous with vascular tissue of the stem. Veins in the leaf is highly branched (net like venation) in the mesophyll layer. Each vein is protected by a bundle sheath layer.

In monocot leaves, stomata are present in both lower and upper epidermis. Mesophyll is not differentiated into palisade and spongy layers. Chloroplasts are abundant in all mesophyll cells. Veins are parallelly arranged (parallel venation).



**Fig. 4.12 T.S of typical Dicot Leaf**



*Fig 4.13 T.S of typical Monocot Leaf*

### **Structure of Stomata**

Stomata are pores surrounded by guard cells in the epidermis of the leaves and stems of plants which can open and close. Guard cells are modified epidermal cells which have a distinct shape and are the only epidermal cells that contain chloroplasts. Guard cells are typically bean shaped in angiosperms. The guard cell walls are unevenly thickened. The inner cellulose wall is thicker and less elastic than the outer wall. Some of the cellulose microfibrils are radially arranged to form inelastic hoops around guard cells.

Guard cells regulate the diameter of the stomata by changing shape, widening or narrowing the gap between the pair of guard cells.

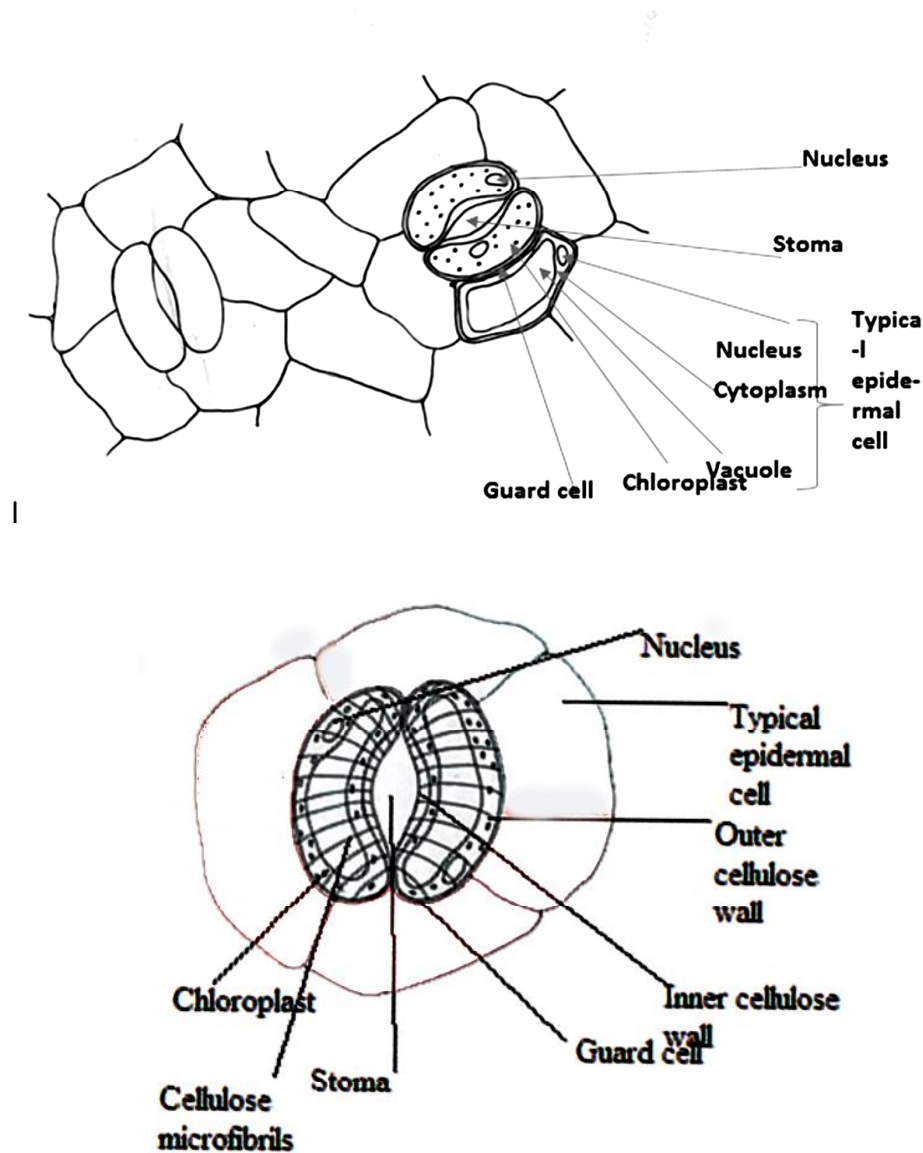


Fig - 4.14 Structure of the stomata

### Gaseous exchange

Gaseous exchange is the exchange of gases between the cells of the organism and the environment. In plants gaseous exchange is possible via stomata and lenticels. In addition to these a small amount of gases can be exchanged via cuticle. There is no special system within plants for the transport of  $O_2$  and  $CO_2$ . These gases move entirely by diffusion.

**Mechanism of opening and closing of stomata**

Stomatal opening and closing depends on changes in turgor of the guard cells. If water flows into the cells by osmosis their turgor increases, and they expand, but they do not expand uniformly in all directions. The relatively inelastic inner walls make them bend and draw away from each other. The result is that the pore opens. If the guard cells lose water, the reverse happens- their turgor decreases, and their inner walls become straighter thus closing the pore.

The  $K^+$  influx hypothesis explains the mechanism.

 **$K^+$  influx hypothesis**

During the day time, the guard cells actively accumulate  $K^+$  from neighboring epidermal cells, thus lowering their water potential that leads to the inflow of water by osmosis from the surrounding epidermal cells. As a result the turgor pressure in guard cells increase, opening stomata.

The accumulation of  $K^+$  in the guard cells requires the energy which is provided by the transfer of electrons during photosynthesis of the chloroplast in guard cells.

Stomatal closing occurs by loss of  $K^+$  from guard cells to neighbouring epidermal cells. It leads to exosmosis of water from guard cells. As a result the turgor pressure in guard cells decrease, closing stomata.

Abscisic acid (ABA) also plays a role in  $K^+$  influx mechanism

**Role of ABA in stomatal closure in drought**

- ABA is produced in roots and leaves in response to water deficiency.
- Production of ABA leads to close the stomata by removal of  $K^+$  in guard cells.
- This prevents the wilting of the plant.

**Factors affecting stomatal action**

- Stomata open during day and mostly closed at night. Light stimulates accumulation of  $K^+$  in guard cells.
- Decrease in  $CO_2$  concentration in substomatal cavity lead to open stomata
- Internal clock in the guard cells controlling their daily rhythm of opening and closing of stomata.
- Environmental stresses such as drought, high temperature and wind can cause stomata to close during the day time.

## Acquisition of water and minerals

### Need for transport

As land plants evolved and increased in number, competition for light, water and nutrients also increased. As a result, the size and complexity of plant body increased. Therefore the simple ways of transportation of water and material became inadequate leading to the evolution of vascular tissues, consisting of xylem and phloem to carry out long distance transport in plants.

e.g. the xylem transports water and minerals from roots to shoots.

the phloem transports products of photosynthesis from where they are made or stored to where they are needed.

### Methods of water and solutes movement

Both active and passive transport mechanisms occur in plants

- Active transport
  - Passive transport
    - Diffusion
    - Osmosis
    - Imbibitions
    - Facilitated diffusion
    - Bulk flow- long distance
- } Short distance

Passive transport occurs spontaneously, and it does not require metabolic energy (ATP). Movement of some materials across membranes takes place using ATP and that process is called an active transport.

### Diffusion

Molecules have an energy called thermal energy, due to their constant motion. One result of this motion is diffusion.

In the absence of other forces, the movement of molecules of a substance from a place where it is more concentrated to place where it is less concentrated, due to random motion of molecules is called diffusion.

The motion of a molecule is random, but movement of a population of molecules by diffusion is directional.

Therefore, diffusion takes place according to a concentration gradient, spontaneously and not using metabolic energy (ATP).

Diffusion takes place across the membrane also, if the membrane is permeable to those molecules.

e.g. Water and soluble materials can diffuse through the cellulose cell wall

O<sub>2</sub> and CO<sub>2</sub> can diffuse through the plasma membrane

### Osmosis

Osmosis is a special type of diffusion. The diffusion of free water molecules across a selectively permeable membrane is called osmosis.

Free water is water molecules that are not bound to solutes or surfaces.

### Imbibition

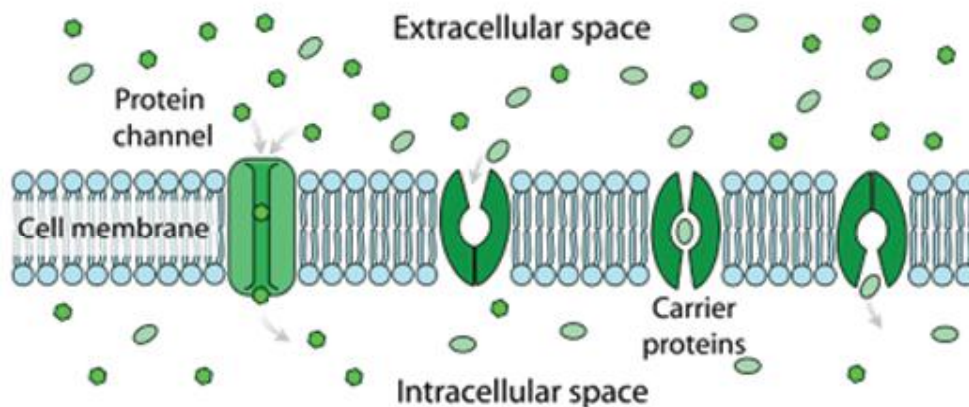
The physical adsorption of water molecules by hydrophilic materials is called imbibition.

e.g. adsorption of water molecules by the cellulose cell walls.

### Facilitated diffusion

Movement of water and hydrophilic solutes across the membranes passively with the help of transport protein that span the membrane is called facilitated diffusion.

Transport proteins are very specific. They transport some substances but not the others. This movement also takes place along concentration gradient and it is a passive movement.



*Fig 4.15 -The process of as facilitated morcment*

### Bulk flow

Bulk flow is the movement of liquid and the materials (entire solution) in response to pressure gradient. Always the bulk flow transports materials from higher pressure to lower pressure region.

It is a long-distance transport method. This flow does not occur through the membranes and occurs at much greater speed than diffusion. This method of transport is independent of solute concentration gradient.



**Concept of water potential**

The physical property that predicts the direction in which water will flow governed by solute concentration and applied pressure is called water potential. Water potential is related to potential energy of water molecules.

Any system that contains water has a water potential. Free water moves from regions of higher water potential to regions of lower water potential, if there is no barrier to its flow.

Water potential is denoted by  $\Psi$ .  $\Psi$  is measured in a unit of megapascal (MPa). Arbitrary the  $\Psi$  of pure water in a container open to the atmosphere under standard conditions (at sea level and room temperature) is 0 MPa.

Both solute concentration and physical pressure can affect water potential; as expressed in the water potential equation.

$$\Psi = \Psi_s + \Psi_p$$

$\Psi$  = water potential

$\Psi_s$  = solute potential

$\Psi_p$  = pressure potential

**Solute potential**

Solute potential ( $\Psi_s$ ) is directly proportional to the molarity of a solution. ( $\Psi_s$  is also called osmotic potential. Solutes affect the direction of osmosis.)

The solutes in plants are typically mineral ions and sugars.

$\Psi$  of pure water is 0 MPa.

When solutes are added, they bind water molecules and reduce free water molecules, reducing capacity of the water to move and do work.

In this way an increase in solutes has a negative effect on water potential. Therefore,  $\Psi_s$  of a solution is always expressed as a negative number. As the solute concentration increases,  $\Psi_s$  will become more negative.

e.g:  $\Psi_s$  of the 0.1M sugar solution is -0.23MPa

**Pressure potential**

Pressure potential ( $\Psi_p$ ) is the physical pressure on a solution.  $\Psi_p$  can be positive or negative relative to atmospheric pressure.

e.g:  $\Psi_p$  of a xylem vessel is usually less than -2 MPa as xylem vessels are under tension (negative pressure)

$\Psi_p$  of a living cell is a positive value because living cell is usually under positive pressure due to osmotic uptake of water.

The cell contents press the plasma membrane against the cell wall. Then press against the protoplast, producing a pressure called turgor pressure. When turgor pressure increases, the  $\Psi$  of cell also increases.

**Water potential of a cell**

Cell is a system containing water. Therefore, it has a water potential. The protoplast is an aqueous system and it contains solutes. Therefore, it has a solute potential ( $\Psi_s$ ) which is negative. Because of  $\Psi_s$ ,  $\Psi$  of the cell is decreased.

Due to the turgor pressure internal pressure of protoplast increases and increases pressure potential ( $\Psi_p$ ) of the cell. Because of  $\Psi_p$ ,  $\Psi$  of cell increased.

Therefore, water potential ( $\Psi$ ) of a cell is given by the following equation.

$$\Psi = \Psi_s + \Psi_p$$

**Entry of water into vacuolated cell across the cell membrane**

If a cell is placed in a solution, direction of water movement depends on the water potential of external solution and protoplast.

Take a fully flaccid cell; (as a result of water losing)

The  $\Psi_p$  of that cell is 0;

$$\Psi_p = 0 ; \Psi_s = \Psi$$

$\Psi_s$  of pure water is 0 and addition of solutes will increase the negative value of  $\Psi_s$  or become more negative. Suppose this flaccid cell is placed in a solution of higher solute concentration (more negative solute potential) than the cell itself, since the external solution has a lower (more negative) water potential, water diffuse out of the cell. The protoplast of the cell shrinks and pulls away from the cell wall. This process is known as plasmolysis.

Suppose this flaccid cell is placed in pure water ( $\Psi=0$  MPa). The cell has a lower water potential than the pure water as it contains solutes. Therefore, water enters the cell by osmosis. Then the protoplast of the cell begins to swell and press the plasma membrane against the cell wall. The partially elastic cell, exerting a turgor pressure, contains the pressurized protoplast. Therefore,  $\Psi_p$  is increased gradually. The maximum value of  $\Psi_p = \Psi_s$  of the cell. Therefore,  $\Psi$  becomes 0. This matches the water potential of extracellular environment, 0 Mpa. Then a dynamic equilibrium is formed and there is no further net water movement. If the cell has the maximum value for  $\Psi_p$ , (it equal to the  $\Psi_s$  of the cell) the cell is said to be in fully turgid state. (fully turgid or fully flaccid cells are not found in nature).

Therefore, if non-woody tissue is placed in a solution with higher water potential, it is stiffened and is very rigid. Therefore, turgor pressure helps support of non woody plants. Turgor pressure is also important in cell elongation. Loss of turgor results in wilting, a condition where leaves and stem droop.

**Movement of water and minerals from soil solution to plant root**

The cells near the root tips of the roots are important because most of the absorption of water and minerals occurs there. In this region, the epidermal cells are permeable

to water and many are differentiated to root hairs. Root hairs account for much of the absorption of water by roots, due to increase in surface area.

The root hairs absorb the soil solution, which consists of water molecules and dissolved mineral ions that are not bound tightly to soil particles. This absorption takes place across the plasma membrane. Water can enter root hair by osmosis, a passive movement along the concentration gradient.

But in the root hairs concentration of mineral ions is greater than that of soil solution.  $K^+$  concentration in the root hair is hundreds of times greater than in the soil solution. Therefore, mineral ion transport occurs against concentration gradient, by an active transport.

The soil solution is also absorbed into hydrophilic walls of the epidermal cells and passes freely along the cell walls and the extracellular spaces into the root cortex.

### **Radial transport**

Transport of water and minerals entered from soil to root cortex into the xylem of the root is known as radial transport.

The endodermis, the innermost layer of cells in the cortex, functions as the last check point for selective passage of the minerals from the cortex into the vascular cylinder. All materials which enters root through cell walls and extracellular spaces should cross the membranes of endodermis. Therefore, unwanted materials can be selectively excluded.

Three routes are used in the radial transport. They are:

1. apoplastic route
2. symplastic route
3. transmembrane route

### **Apoplastic route**

The apoplastic route consists of everything external to the plasma membrane of living cells and includes cell walls, extracellular spaces and the interior of dead cells such as vessel elements and tracheids.

Water and solutes move along continuum of the cell walls and extracellular spaces and it is known as apoplastic route.

Uptake of soil solution by the hydrophilic walls of root hairs provides access to the apoplast. Water and minerals then can diffuse into cortex along this matrix of walls and extracellular spaces.

Endodermis blocks apoplastic route by a barrier located in the transverse and radial walls of endodermal cells, called the casparian strips. It is a belt made of suberin which is impervious to water and mineral salts. Thus water and minerals cannot cross the endodermis and enter the vascular cylinder via apoplast. Therefore, water and minerals

cross the selectively permeable plasma membrane before entering the vascular tissue and keep unneeded and toxic materials out.

The endodermis also prevents solutes that have accumulated in the xylem from leaking back into the soil solution.

### **Symplastic route**

The symplast consists of the entire mass of cytosol of all living cells in a plant, as well as plasmodesmata, the cytoplasmic channels that interconnect them.

In the symplastic route, water and solutes move along the continuum of cytosol. This route requires substance to cross a plasma membrane once, when they first enter the plant. After entering one cell, substances can move from cell to cell via plasmodesmata.

### **Transmembrane route**

The transmembrane route requires repeated crossing of plasma membranes as water and solutes exit one cell and enter the next.

As the soil solution moves along the apoplast, some water and minerals are transported into the protoplast of the cells of the epidermis and cortex and then move via the symplast.

Some substances can use more than one route. The least resistance for the transport is found in apoplastic route. Therefore, more water use apoplastic route.

Finally, water and minerals enter into the tracheids and vessel elements of xylem. These waters conducting cells lack protoplasts when mature and therefore they are parts of the apoplast. Endodermal cells and living cells of the vascular tissues discharge minerals from their protoplast to their own cell walls. Both diffusion and active transport involve in transport of solutes from symplast to apoplast. Then water and minerals can enter the tracheids and vessel elements to the transport to shoot system by bulk flow only through the apoplast.

### **Upward movement of water and minerals in a plant**

Water and minerals which enter to vascular cylinder are transported to upper parts of the plant and this transport is known as ascent of xylem sap.

Xylem sap, the water and dissolved minerals in the xylem, gets transported by bulk flow, which is much faster than diffusion.

To explain the process involved in the ascent of xylem sap, cohesion-tension hypothesis is put forward. According to this hypothesis, transpiration provides pull for the ascent of xylem sap and cohesion of water molecules transmits this pull along the entire length of xylem from shoots to roots. Hence xylem sap is normally under tension (negative pressure).

The negative pressure potential helps water to move up through xylem and water moves according to the water potential gradient.

Adhesion and cohesion facilitate transport water by bulk flow. Due to high adhesion water molecules are attracted to cellulose molecules in the xylem walls. Cohesion of water molecules is unusually high due to hydrogen bonds among water molecules. Therefore, a continuous water column is formed within xylem vessels and tracheids. Transpiration pull can extend down to the root only through an unbroken chain of water.

As water evaporates from the mesophyll cells, water potential of mesophyll reduces, and water moves from cells of petioles to the mesophyll cells. It reduces the water potential of cells of petioles. then water pulls upward due to this transpiration pull.

The xylem sap is driven by difference in pressure potential. Therefore, the water potential gradient within xylem is essentially a pressure gradient.

The tensile force on xylem sap is transmitted all the way from the leaves to the root tips and even into the soil. Therefore, water potential gradient between the soil solution and atmosphere through the plant body also help ascent of xylem sap, against the gravity.

The plants do not need energy to lift the xylem sap.

### **Mechanism of mineral absorption into root**

Mineral ions are absorbed by the plant roots mainly from the soil solution. Epidermal cells are permeable to water and many epidermal cells are modified to form root hairs. Root hair cells are unicellular structures which absorb dissolved mineral ions from the soil solution. Soil solution has a lower concentration of ions than that of the cell sap of root hair cells. Therefore, absorption takes place against a concentration gradient.

## **The process involved in transport of material in phloem**

### **Basic characteristics of phloem transport**

The transport of the product of photosynthesis is carried out by the phloem tissue, known as phloem translocation.

In angiosperms, the sieve-tube elements of the phloem are specialized cells for translocation.

Phloem sap, the aqueous solution that flows through sieve tubes differs from xylem sap mainly because it contains sucrose (as 30% by weight) and it may also contain amino acids, hormones and minerals.

Phloem sap moves from sites of sugar production to site of sugar use or storage. Therefore, it takes place from sugar source to a sugar sink.

Sugar source is an organ that is a net producer of sugar, by photosynthesis or by breakdown of starch.

Plant leaves are sources whereas growing roots, stems, buds and fruits are sinks.

Storage organs such as tubers and bulbs, may be a source or a sink, depending on its function.

### **Mechanism of phloem translocation**

Sinks usually receive sugar from the nearest sugar sources. For each sieve tube, the direction of transport depends on the locations of the sugar source and sugar sink that are connected by that tube. Therefore, neighbouring sieve tubes may carry sap in opposite directions if they originate and end in different locations.

The first step in translocation of sugar is to transport or load into sieve tube elements. In some species, it moves from mesophyll cells to sieve tube elements via symplast, passing through plasmodesmata.

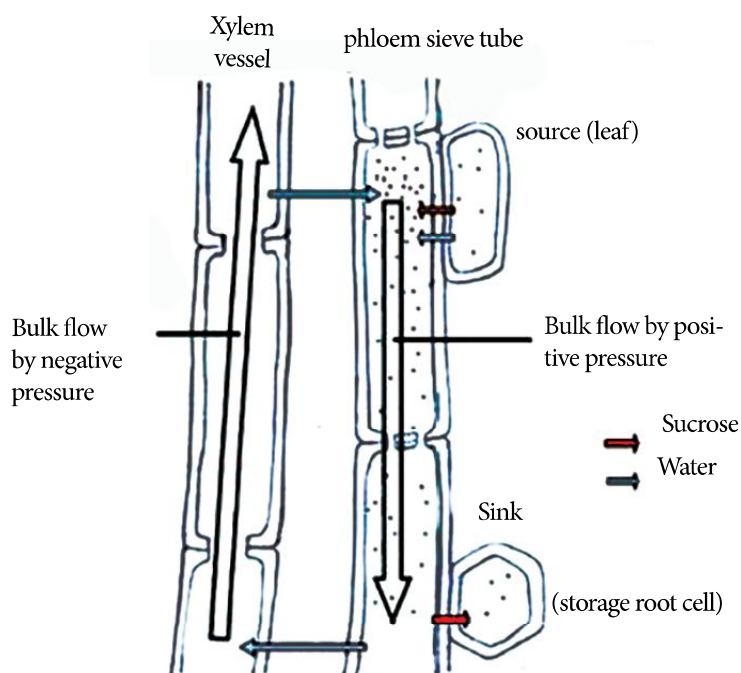
In many plants, sugar movements into phloem requires active transport because sucrose is more concentrated in sieve tube element and companion cells than mesophyll cells.

Sucrose is unloaded at the sink end of the sieve tube. The process varies by species and organ. However, the concentration of free sugar in sink is always lower than in the sieve tube because the unloaded sugar is consumed during growth and metabolism of cells of sinks or converted to insoluble polymers such as starch. As a result of concentration gradient, sugar molecules diffuse from phloem into the sink and water follows by osmosis.

Phloem sap moves from source to sink at a rate about 1m/hr and it moves by bulk flow driven by positive pressure, known as pressure flow.

Phloem translocation of angiosperms is explained by pressure flow hypothesis. In this translocation, following processes take place.

1. Loading of sugar into the sieve tube reduces water potential inside the sieve tube elements at the source
2. This causes the sieve tube to take up water from the xylem by osmosis.
3. This uptake of water generates a positive pressure that forces the sap to flow along the tube
4. The pressure is reduced by unloading of sugar and consequent loss of water from phloem to the xylem at the sink



*Fig 4.16 : The Process phloem transportation*

## Process of water loss in plants

### Transpiration

Removal of water from leaves and other aerial parts of the plant body as water vapour by diffusion is known as transpiration.

This water loss takes place in plants mainly;

through stomata.-stomatal transpiration

upto some extent through cuticle-cuticular transpiration

and through lenticels- lenticular transpiration.

About 95% of water in plants is lost through stomatal transpiration.

In the day time, air in the intercellular air spaces is saturated with water vapour because they are in contact with the moist cell walls. Normally air outside the plant is drier than inside. Hence water potential of outside air is lower than that of inside. Therefore water vapour in the air spaces of the plant diffuses down its water potential gradient and exits the plant.

### Stomatal Transpiration

Water is brought to the leaf in the xylem of vascular bundle and subsequently spread from a fine branching network throughout the leaf. These branches end in one or few xylem vessels or tracheids possessing little lignification. Therefore water can release easily through their cellulose walls to mesophyll cells. Water moves through

the mesophyll cells by apoplast, symplast and transmembrane pathways according to water potential gradient.

Then water evaporate from the wet walls of the mesophyll cells into the intercellular air spaces particularly into the large substomatal air spaces. From here water vapour diffuses through the stomata to the atmosphere.

Immediately next to the leaf is a thin layer of stationary air through which water vapour diffuses out and swept away by moving air.

There is a diffusion gradient from the stationary layer back to the mesophyll cells. Each stomata has a diffusion gradient or diffusion shell around it. The diffusion shell of neighbouring stomata overlap in still air to form one overall diffusion shell (Layer). Thickness of the diffusion shell depends on the surface features of the leaf and wind speed.

### **Factors affecting the rate of transpiration**

1. Light intensity
2. Temperature
3. Humidity
4. Wind speed
5. Concentration of CO<sub>2</sub>
6. Available water in soil

### **Light intensity**

Stomata usually open in the light and close in darkness. With the increase of light intensity the rate of transpiration increases.

### **Temperature**

In the presence of light, the external factor which has the greatest effect on transpiration is temperature. The higher the temperature, the greater the rate of evaporation of water from mesophyll cells which result the greater saturation of the leaf atmosphere with water vapour. At the same time, a rise in temperature lowers the relative humidity of the air outside the leaf. Both events result in a steeper concentration gradient of water molecules from leaf to external atmosphere. The steeper this gradient is the faster the rate of diffusion.

### **Humidity**

Low humidity outside environment of the leaf increases transpiration, because it makes the diffusion gradient of water vapour from the moist leaf atmosphere to drier



external atmosphere. As the concentration of water vapour in the external atmosphere is high when humidity rises, the diffusion gradient becomes less steep result in lower transpiration.

**Wind speed**

In still air, a shell of highly saturated air builds up around the leaf thus reducing the steepness of the diffusion gradient between leaf atmosphere and external atmosphere which makes the transpiration rate low.

In windy condition, flow of air will generally sweep away the shell. Therefore, windy condition increases transpiration rate.

**Availability of soil water**

As soil dries out, water usually binds more tightly to soil particles reducing the amount of available water. The soil solution becomes more concentrated and its water potential decreases. Therefore, tendency for water to enter by osmosis is lower. This reduces water uptake by plants and as a result transpiration rate is also reduced. There is greater resistance to movement of water through the plant due to less steep water potential gradient from the soil through the plant to the atmosphere.

**Significance of transpiration to plants**

1. Distribute minerals and water throughout the plant.
2. Ascent of water in the xylem.
3. Uptake of water and minerals by roots from the soil solution.

**Root pressure and guttation**

At night, when the relative humidity is high approaching 100%, transpiration rate is very low or zero. Root cells continuously pump water and mineral ions into xylem tissue. The endodermis prevents ions from leaking back into the cortex and soil. Therefore more mineral ions accumulate in the vascular cylinder and reduce water potential. Therefore water moves from the cortex. It generates a root pressure and upward push of xylem sap.

Due to root pressure, more water enters to the leaves than lost by transpiration. This results in removal of water droplets from leaf tips or leaf margins of some herbaceous plants. That process is known as guttation. Guttation fluid differs from dew, which is condensed moisture of the atmosphere.

Many plants do not generate any root pressure and therefore there is no guttation. Even in plants that display guttation, root pressure cannot match the water loss by transpiration after sun rise and therefore no guttation is seen in the day time, because then xylem sap is not pushed but pulled upward by transpiration.

Root pressure is never sufficient to push water up distance over meters. Guttation takes place through the hydathode which are formed by special groups of cells located near the ends of small veins and does not take place through the stomata.

e.g. *Alocasia*, *Colocasia*

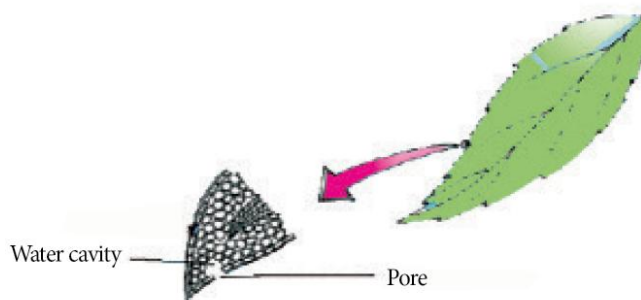


Fig 4,17: The general structure of the hydathode

## Diversity of nutritional processes in plants

Nutrition is the process of acquiring raw materials and energy from the environment for the metabolic activities of organisms.

Plants require nutrients for their growth, development and reproduction.

### Modes of nutrition in plants

#### Autotrophic nutrition (autotrophism)

The organisms who exhibit autotrophism are referred to as autotrophs. Autotrophs synthesize organic materials from  $\text{CO}_2$  and inorganic materials.

Plants are photoautotrophs which utilize light energy in order to synthesize organic molecules from inorganic material.

- **Symbiosis**

Symbiosis is an ecological relationship in which two species live in close contact with each other. There are three types; they are mutualism, parasitism, and commensalism.

- **Mutualism**

A symbiotic relationship in which both participants are benefited.

e.g: legume root nodules with nitrogen fixing bacteria (*Rhizobium*)

mycorrhizae- symbiotic association of roots of higher plants with fungi

coralloid root of *Cycas* with *Anabaena*

- **Commensalism**

It is an interaction between two species in which benefits one of the species and neither harm nor benefits the other.

e.g: epiphytic orchids

- **Parasitism**

It is a close association between two different species which is beneficial to one (the parasite) and harmful to the other (the host).

e.g. semi parasitic–*Loranthus* and host plant

parasitic - *Cuscuta* (Dodder plant) and host plants

- **Special mode of nutrition**

- **Carnivorous plants**

These plants are photosynthetic but obtain nitrogen and minerals by killing and digesting insects and other small animals. They live in habitats where the soil is poor in nitrogen and other minerals.

e.g : *Nepenthes*, *Drosera* , *Utricularia*

## **Nutritional requirements for the optimal growth of plants**

**Essential elements:** Elements which are required for a plant to complete its life cycle and produce another generation.

Seventeen essential elements are needed by all plants

C,O,H,N,P,S,K,Ca, Mg, Cl, Fe, Mn, B, Zn, Cu, Ni, Mo,

Essential elements are two types

Macronutrients

**Macronutrients:** plants need these elements in large amounts.

e.g: C,O,H,N,P,S,K,Ca, Mg (9 elements)

**Micronutrients**

Plants require these elements in small amounts.

e.g: Cl, Fe, Mn, B, Zn, Cu, Ni, Mo

**Table 4.2- Macro elements and their functions and deficiency symptoms**

Element	Form/ forms of intake	Source	Function	Deficiency symptoms
C	CO <sub>2</sub>	Atmospheric air	One of the major components of organic molecules in plants	Poor growth
O	CO <sub>2</sub>	Atmospheric air and soil solution	Major components of organic molecules in plants	Poor growth
H	H <sub>2</sub> O	Soil solution	Major components of organic molecules in plants	Poor growth, wilting
N	NO <sub>3</sub> <sup>-</sup> , NH <sub>4</sub> <sup>+</sup>	Soil solution	Component of amino acids, proteins, nucleotides, nucleic acids, chlorophyll, coenzymes, enzymes	Stunted growth and strong chlorosis, particularly of older leaves
K	K <sup>+</sup>	Soil solution	operation of stomata, cofactors of many enzymes	Yellow and brown leaf margins, weak stems, poorly developed roots
Ca	Ca <sup>2+</sup>	Soil solution	Component of cell walls and middle lamella, maintenance of membrane structure and permeability, signal transduction	Crinkling of young leaves, death of terminal buds
Mg	Mg <sup>2+</sup>	Soil solution	Component of chlorophyll molecule, Activates many enzymes.	Chlorosis between veins, found in older leaves
P	H <sub>2</sub> PO <sub>4</sub> <sup>-</sup>	Soil solution	Component of ATP and nucleic acids, phospholipids	Healthy appearance but very slow development, thin stems, purpling of veins, poor flowering and fruiting
S	SO <sub>4</sub> <sup>-2-</sup>	Soil solution	Components of some amino acids and proteins	Chlorosis in younger leaves

**Micro elements, their functions and deficiency symptoms**

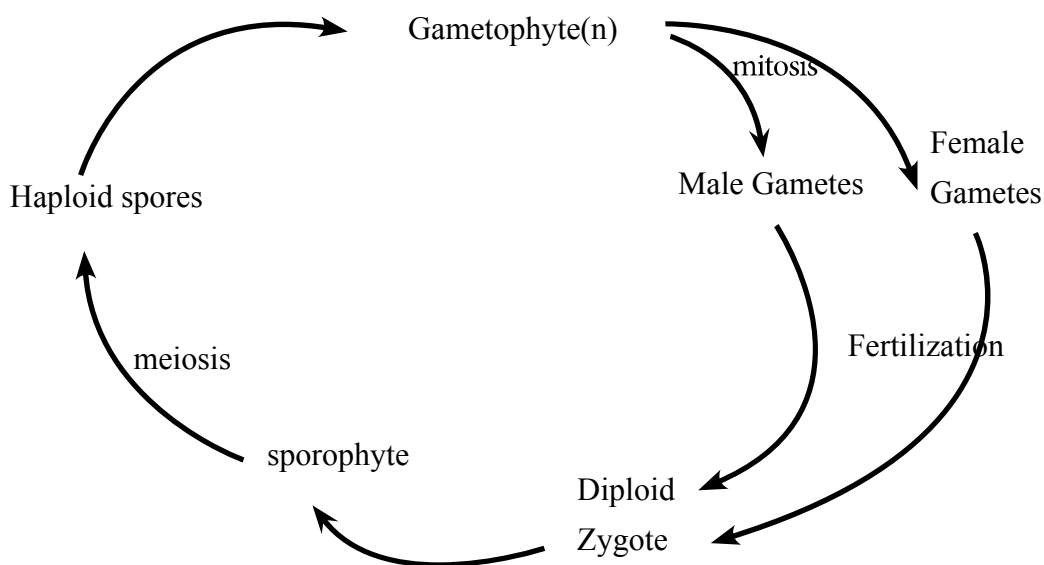
<b>Element</b>	<b>Form/ form of intake</b>	<b>Source</b>	<b>Function</b>	<b>Deficiency symptoms</b>
Cl	Cl <sup>-</sup>	Soil solution	Osmosis and ionic balance, in photosynthesis	Wilting, stubby roots, leaf mottling (uncommon)
Fe	Fe <sup>2+</sup> , Fe <sup>3+</sup>	Soil solution	Chlorophyll synthesis in photosynthesis, N <sub>2</sub> fixation	Chlorosis between veins, particularly in young leaves
Zn	Zn <sup>2+</sup>	Soil solution	Activator of many enzymes and activate formation of Chlorophyll, need for DNA transcription	Crinkled leaves, reduced internode length
B	H <sub>2</sub> BO <sub>3</sub> <sup>-</sup>	Soil solution	Cofactor in chlorophyll synthesis, role in cell wall function, pollen tube growth	Death of meristems, thick leathery, and discolored leaves
Cu	Cu <sup>2+</sup> , Cu <sup>+</sup>	Soil solution	Activator or component of certain enzymes	Light green color throughout young leaves, with drying of leaf tips, roots stunted and excessively branched
Mo	MoO <sub>4</sub> <sup>2-</sup>	Soil solution	Nitrogen metabolism	Death of root and shoot tips, chlorosis in older leaves
Ni	Ni <sup>2+</sup>	Soil solution	Nitrogen metabolism	Death of leaf tips, chlorosis in older leaves
Mn	Mn <sup>2+</sup>	Soil solution	Activates some enzyme require in photosynthesis	chlorosis between veins, found in young leaves

## Reproductive process in Plants

### Trends in life cycles to relate the adaptations of plants for a terrestrial life

#### Sexual reproduction of terrestrial plants

- The life cycles of all land plants exhibit alternation of generations, which means the presence of haploid generation and diploid generation alternatively, with each producing the other.
- The two multicellular body forms that alternate in the life cycles of land plants are the haploid gametophyte and diploid sporophyte which are morphologically different. Therefore called heteromorphic alternation of generations. Their reproductive organs (gametangia and sporangia) are protected by sterile cell layers to prevent desiccation of mother cells. (gamete forming cells and spore forming cells).
- Gametophytes produce gametes by mitosis.
- All land plants carry out internal fertilization to prevent desiccation of gametes.
- Female egg (ovum) is retained in the archegonium and male gametes (antherozoids) are released from the antheridium. Seedless plants depend on external water for fertilization, but seed plants do not depend on external water for their fertilization.
- After fertilization, diploid zygote is retained within the gametophyte to produce an embryo which is nourished by the gametophyte. Embryo develops into the diploid sporophyte.
- Delay of meiosis after fertilization results in creating a diploid sporophytic generation.
- Diploid sporophyte produces haploid spores by meiosis.
- Spores grow into haploid gametophytes.
- In the course of evolution of land plants, diploid sporophytic generation acquire adaptations needed for successful colonization on land and become dominant plant in the life cycle. Gametophytic generation gradually reduced and has become dependent on the sporophytic generation in seed plants.



### Life cycle of Pogonatum

- Gametophyte is the dominant plant, larger and longer-living than sporophyte.
- Gametophyte is photosynthetic.
- ‘Stem’, ‘leaves’, and rhizoids are present in the gametophyte
- Gametophytes are dioecious (unisexual). Mature male gametophytes produce antheridia in which several sperms are produced.
- Female gametophytes produce archegonia. A single egg is produced within the archegonium
- The egg is not released.
- Flagellated, motile sperm swims through external water towards egg, entering the archegonium in response to chemical attractants.
- Sperm fuses with the ovum resulting diploid zygote. This occurs in the archegonium.
- After fertilization zygote develops into the embryo.
- The embryo is also retained within the archegonium and develops into the diploid sporophyte by obtaining nutrients from the gametophyte.
- The sporophyte remains attached to the gametophyte.
- The sporophyte consists of a foot, seta and a capsule (sporangium).
- The foot absorbs nutrients and water from the gametophyte.
- The capsule produces spores by meiosis. Homosporous.
- If spores are dispersed to a favourable habitat, (such as moist soil or tree bark) they may germinate and grow into a green, branched filament called protonema.
- Protonema produces buds that grow into gametophytes.

**Life cycle of *Nephrolepis***

- Sporophyte is dominant
- Gametophyte is reduced and short lived.
- Both sporophytes and gametophytes are independent and photosynthetic.
- Sporophytes have more complex structure.
  - Plant body is differentiated into roots, stem and leaves.
  - Cuticle is found on aerial parts of the plant body
  - Stomata are developed on aerial parts for gaseous exchange.
  - Two types of vascular tissues, xylem and phloem are developed
  - They have fiddlehead young leaves
  - Stem is an underground rhizome
  - Leaves are compound pinnate leaves
  - Long underground branches called stolons arise from the rhizome \ which gives rise to new plantlets.
  - Sporangia are developed as clusters called sori on the underside of mature leaflets. Sori are covered by the indusium, protecting the young sporangia from desiccation. Spores are produced in the sporangium by meiosis and are homosporous.
- When the sorus matures, indusium dries up and shrivels, exposing mature sporangia.
- Under dry environmental conditions sporangium wall ruptures, releasing spores.
- Spores are dispersed by wind.
- When spores are dispersed to a favourable habitat they may germinate and grow into a gametophyte
- Gametophyte is a small heart shaped, macroscopic, green coloured photosynthetic thallus.
- Rhizoids develop on the ventral surface.
  - Gametophytes are monoecious (bisexual). Antheridia and archegonia are developed on the ventral side.
  - Antheridium produces flagellated sperms and releases them into the external environment.
  - Archegonium produces one egg and retains it.
  - Motile sperms swim through external water towards egg entering the archegonium in response to chemical attractants.
  - Sperm fuses with the egg resulting the diploid zygote.
  - After fertilization zygote develops into the embryo and then to the young sporophyte while retained in the gametophyte.
  - All the developmental stages are nourished by the gametophyte.



- When the young sporophyte develops its photosynthetic tissues, it becomes an independent plant.

### **Life cycle of *Selaginella***

- Sporophytes are dominant and photosynthetic.
- Gametophytes are reduced in structure and short-lived, partially depend on the sporophyte.
- Sporophyte plant body is differentiated into roots, stem and leaves. Vascular tissues present. Herbaceous.
- Heterophyllous leaves are arranged as pairs.
- Stem is dorsiventrally flattened.
- Sporangia are borne on the specialized leaves called sporophylls.
- Sporophylls are compactly arranged in a terminal strobilus.
- Two types of sporophylls called megasporophyll and microsporophyll are arranged in the same strobilus.
- Megasporophyll produces a single megasporangium and microsporophyll produces a single microsporangium.
- Morphologically two different types of spores are produced. This nature is called heterospory.
- Megasporangium produces four large megaspores by meiosis.
- Microsporangium produces numerous small microspores by meiosis.
- Both types of spores have thick/tough walls.
- Microspores are retained in the microsporangium and develop into young male gametophytes.
- Young male gametophytes are enclosed by the wall of microspore which, are released by the microsporangium.
- In the external environment they become mature male gametophytes.
- Male gametophytes is microscopic, enclosed in the microspore wall, non-photosynthetic, depend on stored food.
- Male gametophytes produce flagellated sperms and release them into the external environment.
- Megaspores are released into the external environment. In the external environment they develop into female gametophytes.
- Female gametophyte is multicellular, surrounded by the thick wall of megaspore, Few rhizoids develop.
- Photosynthetic, but partially depend on stored food in the megaspore.
- Archegonia develop at the superficial regions and are fully embedded in the gametophytic tissue.

- One egg is produced inside the archegonium.
- Sperm swims towards the egg (n) using flagella through external water, entering into the archegonium and fertilizes the egg (n) resulting in a zygote(2n).
- Zygote develops to form an embryo and then embryo develops to form a young sporophyte by obtaining nutrients from the female gametophyte.
- Sporophyte generation is the larger and more complex form in the alternation of generation

### **Life cycle of *Cycas***

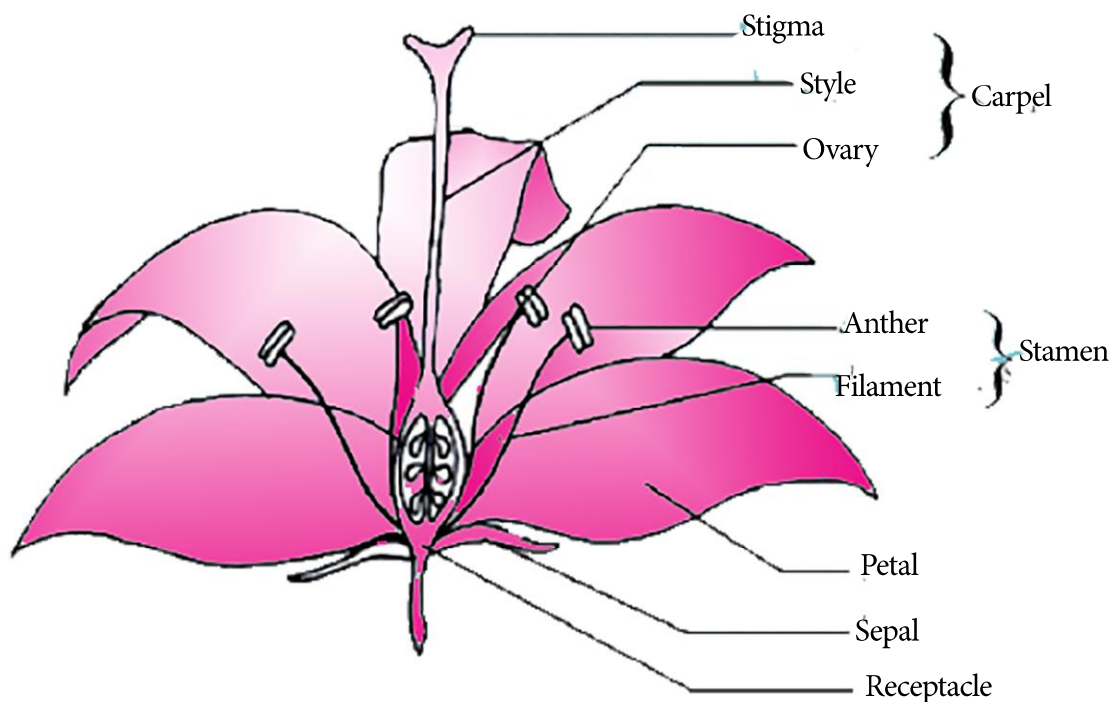
- Sporophytes are the dominant photosynthetic plants in the life cycle, gametophytes are reduced and depend on the sporophyte throughout its life.
- Sporophytes are a perennial tree with roots, stem and leaves.
- Stem is unbranched columnar and woody.
- Leaves are arranged in crowns.
- Compound leaves show xerophytic adaptations and young leaves are fiddleheads.
- Sporophytes are heterosporous and dioecious. Sporophytes have developed a tap root system.
- Secondary growth is present.
- Sporophytes which produce megaspores are called female plants and those which produce microspores are called male plants.
- Mature female plant produces a crown of megasporophylls.
- Megasporangium is enclosed in the protective layer called integument to form the ovule. Integument has a small pore in the distal end of the ovule called micropyle.
- One of the cells in the megasporangial tissue differentiates into a single megaspore mother cell. Megaspore mother cell undergoes meiosis to form four haploid megaspores out of which only one remains functional.
- The remaining megasporangial tissue functions as nucellus which provides nourishment.
- Megaspores are not released to the external environment megaspore develop into the female gametophyte (n) while within the ovule. Mature ovule contains the female gametophyte. The female gametophyte produces several archegonia. Each archegonium produces a single egg cell within it.
- Mature male plants produce male cones with microsporophylls which consist of microsporangia on the lower surface. Large numbers of microspores (n) are produced from microspore mother cells (2n) within the microsporangium by meiosis.

- They develop into pollen grains within the sporangium and then discharge.
- Pollen grains are dispersed by wind and deposited on the micropyle of a mature ovule is called pollination.
- Pollen grains enter into pollen chamber of the ovule through the micropyle. In the pollen chamber, pollen grains develop into male gametophytes. Male gametophyte consists of a branched pollen tube which involves in absorption of nutrients from the nucellus. Male gametophyte is short-lived.
- Produce two large sperms with a spiral band of numerous cilia.
- The basal end of the pollen tube ruptures releasing sperms into the archegonial chamber of the ovule. Sperms swim through the liquid medium and fertilize the egg resulting the  $2n$  zygote.
- Zygote develops into the embryo
- Remaining female gametophyte becomes the endosperm which provides nutrients for the developing embryo during seed germination. Integument becomes the seed coat.
- The ovule becomes the seed.
- Seed is the dispersal unit which contains the embryo and stored food that are enclosed in the seed coat.
- Seeds are dispersed and under favorable environmental conditions seeds germinate producing the seedlings (young Sporophyte).

## **structures and functions associated with sexual reproduction in flowering plants**

### **Life cycle of flowering plants**

- Sporophyte is the dominant plant. Gametophytes are short-lived, microscopic, entirely depend on the sporophyte.
- Sporophyte produces the reproductive structures called flowers.
- A flower is a specialized shoot with four whorls of modified leaves named sepals, petals, stamens and carpels.
- Sepals are usually green, enclose and protect the flower before it opens.
- Petals are brightly coloured in most flowers and aid in attracting pollinators. (But wind pollinated flowers generally lack brightly coloured parts).
- The sepals and petals are sterile floral organs. They do not directly involve in reproduction.
- Stamens are the microsporophylls.
- The stamen consists of a stalk called filament and two terminal lobes called anther.



#### 4.16 Structure of a typical angiosperm flower

- Anther is made up of microsporangia (pollen sacs) containing microspore mother cells which produce microspores by meiosis. Microspores develop into pollen grains within the anther.
- A pollen grain contains two nuclei, the tube nucleus and generative nucleus.
- Carpels are the megasporophylls. At the tip of the carpel is a sticky stigma that receives pollens. The swollen base of the carpel forms the ovary. Ovary contains one or more ovules. A long, slender neck called style connects ovary with stigma.
- Ovule produces four megaspores by meiosis of which only one becomes functional.
- Functional megaspore develops into the female gametophyte called the embryo sac. It is a highly reduced microscopic structure.
- The mature embryo sac consists of eight nuclei contained within seven cells—three antipodal cells, two polar nuclei in the central cell, two synergids and one egg.
- Transfer of pollen grains to a mature stigma is known as pollination.
- In some plant species, pollen grains are transferred from an anther of a flower on to the stigma of the same flower. This is self-pollination.
- Pollen may be transferred to a stigma of a different flower. This is cross pollination.

- Most angiosperm plants are adapted for cross pollination.
- Typical characteristics of flowers like such as colour and odour. favour cross pollination.
- In addition, some plants show special types of adaptations cross pollination.  
e.g. heterostyly, self infertility, unisexuality

### **Significance of cross pollination**

Cross pollination results in cross fertilization. Cross fertilization allows shuffling of genes within a species, producing new genetic combinations resulting increased genetic variation within the species. These features are very important for survival and also might lead to evolution.

### **Fertilization**

- The pollen grain germinates after it is placed on the stigma.
- It extends a pollen tube that grows down through the style of the carpel.
- The generative nucleus divides forming two sperm nuclei.
- When the pollen tube reaches the ovary, it moves through the micropyle (The pore in the integuments of the ovule) and discharges two sperm nuclei into the embryo sac.
- One sperm nucleus fuses with the egg cell forming a diploid zygote and the other sperm nucleus fuses with the 2 polar nuclei. This type of fertilization is called double fertilization and is unique to angiosperms.
- After double fertilization, the ovule matures into a seed. The zygote develops into the embryo. The triploid nucleus develops into the endosperm that store food.
- The significance of double fertilization is that it synchronizes with the development of the embryo.
- If fertilization does not occur that prevents plants from wasting nutrients on infertile ovules.
- The seed consists of the embryo, endosperm with store food and a seed coat.
- Seeds are enclosed in the fruit.
- Fruit is an enlarged and developed ovary, usually after being stimulated by fertilization. Fertilization triggers hormonal changes that cause the ovary to form a fruit.
- If a flower has not been pollinated, fruit does not develop, and entire flower falls away.
- During fruit development, the ovary wall gets converted to the pericarp.
  - In some plants fruits develop from the ovary without fertilization. This is called

parthenocarpy. Parthenocarpic fruits do not develop seeds. Parthenocarpy occurs naturally in some species.

e.g. Banana

- It also can be induced with plant growth substances to get seedless fruits.

e.g. Grapes, Orange

- In some plants, seeds develop without fertilization. This is called parthenogenesis.  
e.g. certain grasses
- In parthenogenesis,
  - the egg is resulted by mitosis and hence is diploid, or
  - haploid ovum fuses with a polar nucleus, or
  - the genetic content of the egg is duplicated to become diploid, enabling seed development without fertilizing by the sperm.

### **Significance of development of seed and fruit**

#### **Seed**

- Seed is the dispersal unit of seed plants which contains the embryo and stored food, surrounded by the seed coat
- The seed habit has a strategy for life on land: The presence of,
  - seed coat- helps to survive in extreme conditions
  - food reserves-provide nourishment to the embryo during development
  - dormancy period helps to survive during unfavorable conditions
  - adaptations for dispersal give a better chance for growth , development and survival.

#### **Fruits**

- Protects the enclosed seeds
- When mature, aids in their dispersal by wind , water or animals.
- After being dispersed, if environmental conditions are favourable, a seed may germinate to form a seedling.
- Inhibition of embryo within the seed at one stage of maturation, naturally prevents germination of seeds within fruit, which is called seed dormancy.
- Many seeds have mechanisms of inhibiting germination and remain dormant.
- Presence of inhibitors, presence of thick/strong seed coats, presence of seed coats impervious to water are common causes of seed dormancy.
- After breaking seed dormancy, when water, oxygen and suitable temperature are provided, seeds start to germinate.
- Absorption of water, activation of enzymes, mobilization of food resources

(nutrients) followed by rapid growth process of the embryo extending radical through the seed coat is called seed germination. Radical shows positive geotropism and plumule shows negative geotropism.

## **Plant responses to internal and external Signals**

### **Responses of plants to different stimuli**

#### **Photomorphogenesis:**

- Light triggers many key events in plant growth and development, collectively known as photomorphogenesis.
- Light reception also allows plants to measure the passage of days and seasons.
- Plants detect not only light signals, but also the direction, intensity and wave length (Color)
- A graph called an action spectrum depicts the relative effectiveness of different wave lengths of radiation in carrying out a particular process, such as photosynthesis.
- Action spectrum reveals that red and blue light are the most important colors in regulating plant's photomorphogenesis.
- The two major classes of light receptors in plants are the blue light photoreceptors and phytochromes (which absorb mostly red light)
- Blue- Light photo receptors initiates a variety of responses in plants, including phototropism, the light induced opening of stomata and the light induced slowing of hypocotyl elongation that occurs when a seedling breaks ground.
- Phytochrome photoreceptors regulate many plant responses to light, including seed germination and shade avoidance.

#### **Effect of light on:**

##### **seed germination.**

- As the nutrient reserves are limited, many types of seeds (especially small ones) germinate only when the light environment and other conditions are nearly optimal.
- Such seeds often remain dormant for years until light conditions change. (e.g.- Plowing a field or a death of a shady tree may create a favorable light environment for germination)

##### **plant spacing**

- Phytochromes provide the plant with information about the quality of light which enables the plant to get adapted to changes in outside light conditions.  
e.g. "Shade Avoidance" response of a forest tree (below the canopy) that requires

relatively high light intensity. As the forest canopy absorbs more red light allowing only far red light to pass through, the tree below the canopy will allocate more of its resources to grow taller.

- In contrast, exposure to direct sunlight increases the proportion of far red: red light and thereby stimulates branching and inhibits vertical growth.

### **flowering**

- Photoperiod is the interval in a 24hour period in which the plant gets exposed to light.
- Photoperiod controls flowering in many types of plants.

### **Shoot elongation and Phototropism**

- The growth of a shoot towards light (positive) or away from it (negative) is called phototropism.
- Positive phototropism strengthen photosynthesis.
- This response results from a differential growth of cells on opposite sides of the shoot; the cells in the darker side elongate faster than the cells on the brighter side.

### **Response to Gravity**

#### **Gravitropism**

- Shoot of the plant grows upwards while root grows downwards, due to their response to gravity or gravitropism.
- Gravitropism can be either positive or negative.  
e.g. Roots display positive gravitropism while shoot display negative gravitropism.
- Gravitropism occurs as soon as a seed germinates. This ensure that the root grows into the soil and shoot grows towards sunlight.
- Plants may detect gravity by the settling of statoliths.
- Statoliths of vascular plants are specialized plastids containing dense starch grains.
- They can settle under the gravity, to the lower portions of the cell.
- In roots, they are located in certain cells of the root cap.



**The statolith hypothesis:**

The aggregation of statoliths at the low points of root cap cells triggers re-distribution of  $\text{Ca}^{2+}$  which causes lateral transport of auxin within the root. As a result, Ca and auxin get accumulated at lower side of elongation zone of root. At high concentration of auxin, cell elongation is inhibited resulting slow growth on lower side and more rapid elongation on upper side. Consequently, the root grows downwards.

**Response to mechanical stimuli**

Trees grow in windy environment normally have shorter stockier trunks than same species growing in normal environmental conditions. Advantage of this is that the tree could stand high winds. This exhibits the sensitivity of mechanical stress of plants. The changes in plant form due to mechanical disturbances is called thigmomorphogenesis. During evolution, some plant species have become 'touch specialists'. Climbing plants have tendrils that coil rapidly around support. Tendril usually grows straight until it touches a support. The contact stimulates differential growth on opposite sides of the tendril. The directional growth of tendril towards support is called thigmotropism.

Other touch specialists, respond to touch by rapid leaf movements. E.g. *Mimosa pudica* collapses its leaflets when touched. Touching results in a sudden loss of turgor of cells in a specialized motor organ called pulvini, causing the leaflets to collapse. This response is called thigmonasty.

**The role of plant growth substances/ hormones/ regulators in response to different stimuli**

Hormones in general are signaling molecules which are produced in small quantities, get transported from the place they are produced to other parts of the organism and trigger responses in target cells. or/and effect on plant growth and development. With this definition, its hard to explain some physiological processes in plants. In addition, some signaling molecules that are considered as plant hormones act locally. Thus the broader term plant growth regulators seem more appropriate.

Plant growth regulators are natural or synthetic organic compounds which modify or control specific physiological process in plants.

Plant biologists prefer to use the term plant growth regulators rather than plant hormones, as there are certain differences in plant hormones and animal hormones.

Therefore, plant hormones and plant growth substances are considered as equal. But plant hormones are active even at very low concentration.

Major types of plant hormones/ growth regulators are auxins, gibberlin, cytokinin, abscisic acid, ethylene and Jasmonate (jasmonic acid).

Hormone	Functions
Auxin	<ul style="list-style-type: none"> <li>• stimulates stem elongation in low concentration</li> <li>• promotes the formation of lateral and adventitious roots</li> <li>• regulates development of fruit</li> <li>• enhances apical dominance</li> <li>• functions in phototropism</li> <li>• functions in gravitotropism</li> <li>• promotes vascular differentiation</li> <li>• retards leaf abscission</li> </ul>
Gibberellins	<ul style="list-style-type: none"> <li>• stimulate stem elongation</li> <li>• stimulate pollen development</li> <li>• stimulate pollen tube growth</li> <li>• stimulate fruit growth</li> <li>• stimulate seed development and germination</li> <li>• regulate sex determination and transition from juvenile to adult phase</li> </ul>
cytokinins	<ul style="list-style-type: none"> <li>• regulate cell division in shoots and roots</li> <li>• modify apical dominance and promote lateral bud growth</li> <li>• promote movement of nutrients into sink tissues</li> <li>• stimulate seed germination</li> <li>• delay leaf senescence</li> </ul>
Abscisic acid	<ul style="list-style-type: none"> <li>• inhibits growth</li> <li>• promotes stomatal closure during drought stress</li> <li>• promotes seed dormancy and inhibits early germination</li> <li>• promotes leaf senescence</li> <li>• promote desiccation tolerance</li> </ul>
Ethylene	<ul style="list-style-type: none"> <li>• promotes ripening of many types of fruit</li> <li>• promote leaf abscission</li> <li>• promote triple response in seedlings (inhibition of stem elongation, promotion of lateral expansion, and horizontal growth)</li> <li>• enhance the rate of senescence</li> <li>• promote roots and root hair formation</li> <li>• promotes flowering in the pineapple family</li> </ul>

## Response of plants to some biotic and abiotic stresses

### Stress

Certain factors in the environment may have a potentially adverse effects on a plants' survival, growth and reproduction.

Two types of stresses,

1. Abiotic stress
2. Biotic stress

## Response of plants to some biotic and abiotic stresses

### Stress

Certain factors in the environment may have potentially adverse effects on plants' survival, growth and reproduction.

Two types of stresses;

3. Abiotic stress(due to nonliving factors)
4. Biotic stress (due to living factors)

### Abiotic Stress

Among several common abiotic stresses. Following three stresses are discussed.

1. Drought stress
2. Cold stress
3. Salt stress

**1. Drought stress:** Plants may wilt when water loss by transpiration exceeds water absorption. Prolonged drought may even kill a plant. Plants have control systems that enable them to cope with the drought/ water deficit conditions.

Water deficit stimulates increased synthesis and release of abscisic acid (ABA), which acts on guard cell membrane, closing stomata to reduce transpiration.

In grasses the leaves roll in to a tube-like shape which reduces the surface area to reduce transpiration. Some plants shed their leaves during seasonal drought.

**2.Cold stress:** When cell membrane cools below a critical temperature it loses its fluidity due to the lipids become locked in to crystalline structure. This blocks the transport across the membrane and affects the function of the cell.

Plants respond to cold stress by altering the lipid composition of their membranes. They increase the proportion of unsaturated fatty acids which keeps the membranes more fluid at low temperature.

Freezing is another cold stress. Water in the cell wall and intercellular spaces freezes before freezing the solute-rich water in the cytosol. The reduction of liquid water in the cell wall lowers the extracellular water potential causing water in the cytosol to leave.

This results high concentration of solutes in the cytoplasm which is harmful and may lead to cell death.

Before the onset of winter, the cell of frost-tolerant plants increases cytoplasmic levels of specific solutes such as sugars that help to reduce the loss of water from the cell preventing dehydration.

**3. Salt stress:** An excess of salts (high salinity) in soil lowers the water potential of soil resulting reduced water potential gradient from soil to root. This leads to reduction of water uptake by roots.

In general too high salinity in soil is toxic to plants.

Many plants can respond to moderate soil salinity by producing solutes that are well tolerated at high concentrations. These are organic compounds that keep the water potential of cell more negative than that of the soil solution.

A few plants that are salt-tolerant (halophytes) have developed salt glands, which secrete excess salts out of the plant across leaf surfaces. e.g. many mangrove plants

### **Biotic stress –**

How plants defend themselves against pest and pathogens attack;

In plant defense mechanisms, some compounds and structures are already existed whilst some others are formed after infection or pest attack. Therefore, two categories of defense mechanisms called preexisting and induced mechanisms can be identified.

Preexisting structural and chemical defense mechanisms;

- Amount and quality of wax and cuticle that cover the epidermal cells
- The structure of the epidermal cell walls and thickness
- The size, location and shapes of stomata
- Toxic compounds, alkaloids (eg. Nicotine), phenolics (eg. Flavonoids, lignin & tannins), terpenoids (eg. Azadirachtin) and lectin
- Thorns, pricks, trichomes

### **Induced structural and chemical defense mechanisms;**

- Morphological changes in the cell wall
- Formation of cork and abscission layers
- Phenolic compounds
- Toxic compounds
- Enzymes that can degrade fungal cell walls or damage insect organs

**05****Animal form and function****Relate the Structure of Animal Tissues to their function**

There are four major types of animal tissues : Epithelial tissue, Connective tissue, Muscle tissue and Nervous tissue.

**1. Epithelial tissue: -****Characteristics**

It covers external or internal free surfaces and organs. The cells of the tissues are closely packed. Cells of epithelial tissue have both apical and basal surfaces where apical surface remains free and the basal surface attached to the basement membrane. No blood vessels in the tissue. Tissue gets nutrients and oxygen from the underneath connective tissue.

**Functions-**

- Protection (e.g. barrier against mechanical injury, pathogens, barrier against fluid loss)
- Secretion (e.g. enzymes, hormones, mucus, sweat)
- Absorption (e.g. nutrients, respiratory gases )

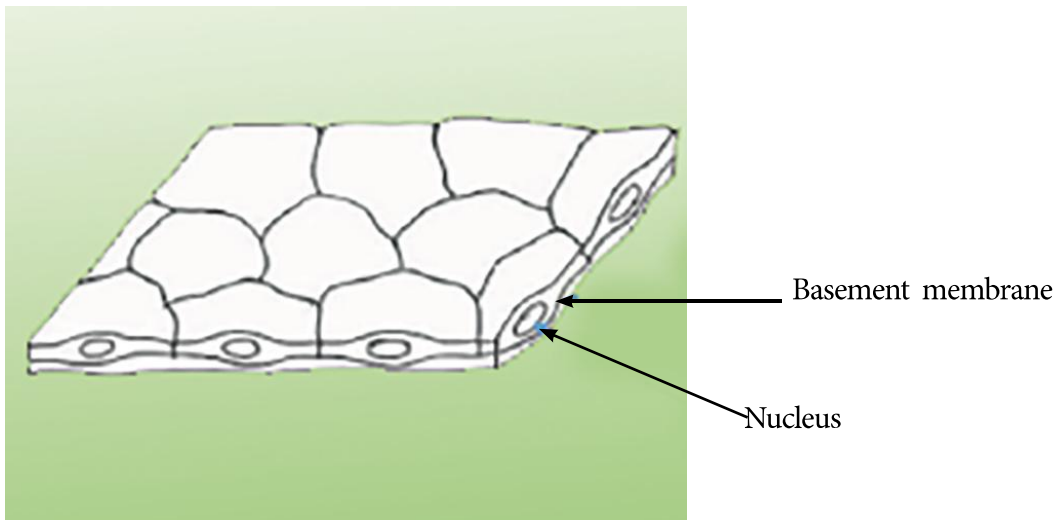
There are two general types according to the number of cell layers on the basement membrane.

- Simple epithelia – Single cell layer (e.g simple squamous, simple cuboidal, simple columnar and pseudostratified)
- Compound epithelia – several cell layers (e.g. stratified squamous, transitional)

**Simple squamous epithelium –**

It is a single layer with plate like cells. This type of epithelium is thin and leaky. They are found in places where materials exchange by diffusion.

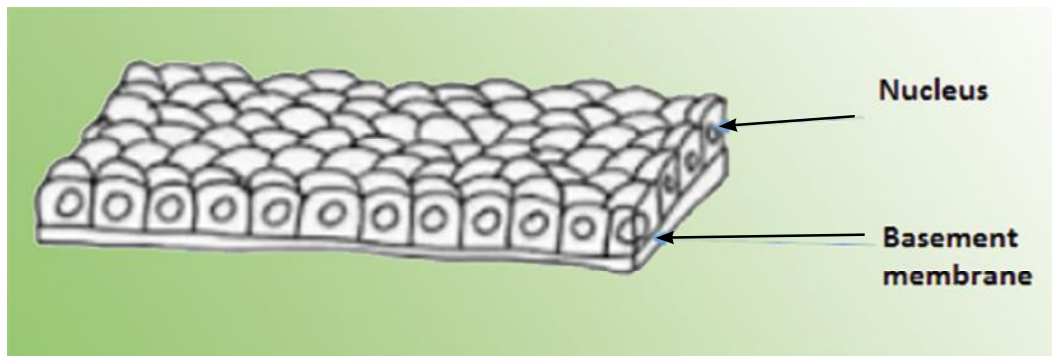
e.g: blood capillaries, alveoli,



*Fig 5.1: simple squamous epithelium*

#### **Simple cuboidal epithelium –**

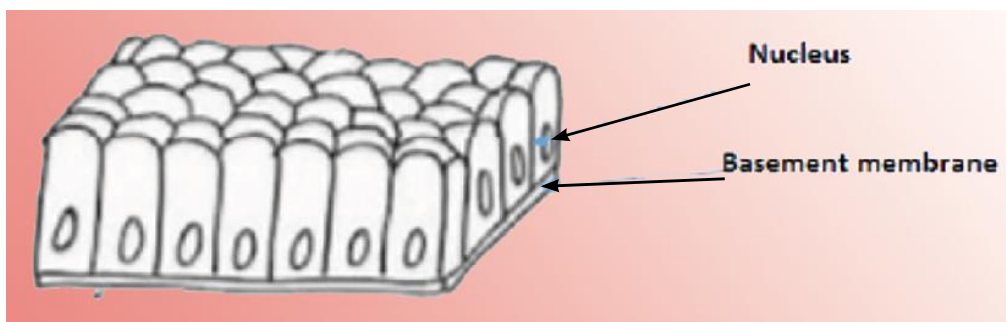
It is a single cell layer with dice shaped cells specialized for secretion. It is found in kidney tubules, many glands such as thyroid glands and salivary glands



*Fig 5.2: simple cuboidal epithelium*

#### **Simple columnar epithelium**

It is a single layer with large and brick-shaped cells. It is often found in places where secretion or active absorption is important. e.g. intestinal lining



*Fig 5.3 : simple columnar epithelium*

### Pseudostratified columnar epithelium

This tissue consists of a single cell layer. Cells are not of equal height. Nuclei of cells are located at different level. Appear as several layers. In many vertebrates this epithelium has ciliated cells that form a mucous membrane and the cilia help to sweep the mucous along the surface. e.g. nasal passage, trachea.

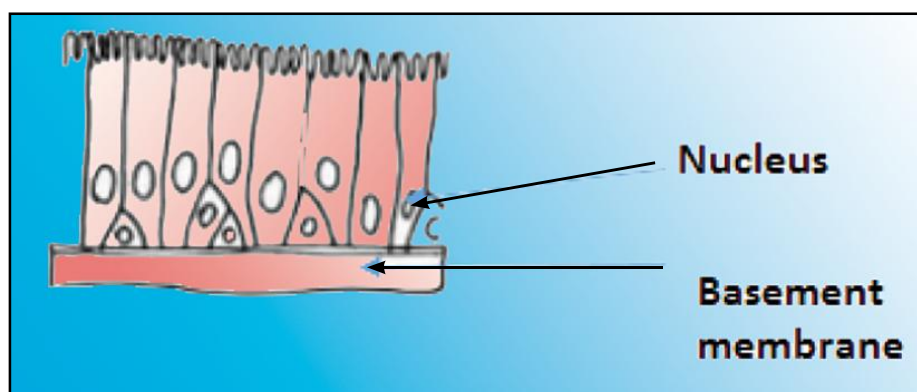


Fig 5.4 : Pseudostratified squamous epithelium

### Compound epithelia –

#### Stratified squamous epithelium:

This tissue is composed of a number of layers of cells. This epithelium regenerates rapidly. Cell division produces new cells near the basement membrane. The old cells are sloughed off and replaced by the new cells. This epithelium is found on surfaces where they are subjected to abrasion such as outer skin, lining of mouth, anus, vagina

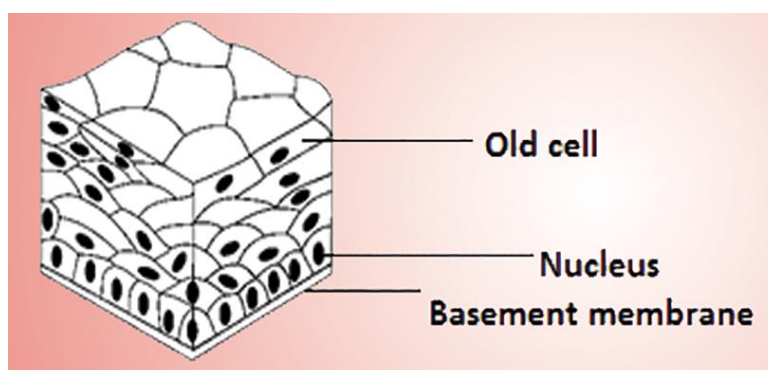


Fig 5.5: Stratified squamous epithelium

## 2. Connective tissue

### Characteristics

Connective tissues are the most abundant tissues in the body that help to connect organs and tissues together structurally and functionally. These types of tissue consist of different types of cells scattered in a large amount of extracellular matrix containing different types of fibres. Matrix may be a semisolid (Jelly-like), liquid or

solid (dense and rigid). Different types of cells can be found in the matrix such as fibroblasts (secrete fiber proteins), macrophages (engulf foreign particles or any cell debris by phagocytosis) and mast cells ( secrete heparin and histamine) in addition fat cells (storage and insulation) and leukocytes (protection) are found in some connective tissues.

There are three different types of fibers. They are collagen fibers (provide strength and flexibility), reticular fibers (join connective tissues to adjacent tissues) and elastic fibers (make tissue elastic).

### **Functions**

- Binding and structural support
- Protection
- Transport of materials
- Insulation

There are different types of connective tissues. They are loose connective tissue (Areolar tissue), Fibrous connective tissue (Dense connective tissue), adipose tissue, blood, cartilage and bone .

### **Loose connective tissue (Areolar Tissue)**

This tissue is the most widely distributed connective tissue type in the vertebrate body. This can be considered as the generalized type of connective tissue. Types of cells in this tissue are fibroblasts, macrophages, mast cells, leukocytes and fat cells.

All three types of fibres are found in this tissue. Fibers are loosely arranged and wavy in nature. This tissue binds epithelia and the underlying tissue. Therefore this holds organs in place. This tissue is found under the skin and throughout the body.

### **Fibrous connective tissue (Dense connective tissue)**

This tissue is densely packed with collagen fibers. Therefore the matrix is relatively reduced and contains fewer cells (fibrocytes). This tissue is found in tendons (attach muscle to bones) and ligaments (connect bones and joints) where tensile strength is required.

### **Adipose tissue**

This tissue is packed with adipose cells. Each adipose cell contains a large fat droplet. This is a specialized type of loose connective tissue which pads and insulates the body and stores fuel as fat molecules. For instance, it is found under the skin where it act as a thermal insulator and energy store.



**Blood tissue**

It is a specialized connective tissue where the matrix is not secreted by the cells and fibers are formed only during blood clotting process. The extracellular matrix of the blood is liquid. It is called as plasma. The blood plasma contains salts, water and dissolved proteins. Red blood cells (transport respiratory gases), white blood cells (defense) and platelets (blood clotting) are suspended in the blood plasma. Main functions of blood tissues include transport of materials, protection, and osmoregulation. (For further details refer pg 195)

**Cartilage**

This tissue consists of a matrix composed of chondroitin sulphate which is a rubbery protein-carbohydrate complex. Collagen fibers and chondrocytes are embedded in the matrix. Chondrocytes secrete chondroitin sulphate and collagen fibers. This tissue provides support and flexibility in places such as trachea, intervertebral discs.

**Bone**

It is a mineralized connective tissue. Matrix consists of collagen fibres and inorganic salts. Inorganic salts are Calcium, magnesium and phosphate ions. Cells are osteoblasts (bone forming cells) and osteocytes (mature bone cells that maintain bone tissue). Osteocytes are enclosed within lacunae. The mammalian hard bone has repeating units called osteons. Each osteons has a concentric layer of mineralized materials. At the centre of the osteon is a central canal containing blood vessels and nerves. This tissue forms the endoskeleton of most vertebrates and provides support and strength to the body.

**3. Muscle tissue**

Muscle tissue is responsible for movement. The cells in the muscle tissue are composed of actin and myosin proteins. This tissue is able to contract and relax. There are three basic types of muscle tissues found in the vertebrate animal body. They are smooth muscle, skeletal muscle and cardiac muscle tissues.

**Smooth muscle tissue**

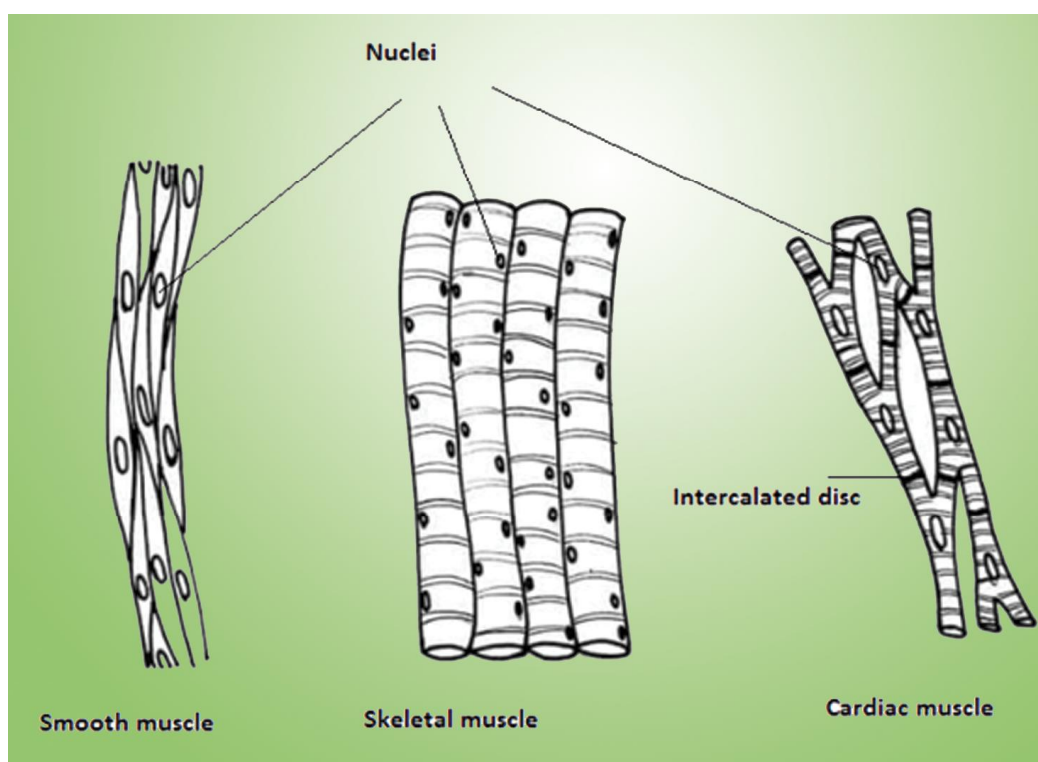
The cells of the smooth muscle tissue are spindle shaped and uninucleated. Cells lack striations. This tissue is responsible for involuntary body functions (e.g. churning of stomach, constriction of arteries). This tissue is found in digestive tract, urinary bladder, arteries and other internal organs.

### Skeletal muscle tissue

They are composed of bundles of long cells with multi nuclei. Cells are striated. The contractile units of this muscle cells are called sarcomers. This gives the striated appearance to the muscle cells. The arrangement of the sarcomere gives the striated appearance. The muscles are generally attached to the skeletal system and helps mainly in voluntary body movements.

### Cardiac muscle tissue

They are composed of uninucleated cells which are interconnected via intercalated discs. Cells are striated with sarcomeres. Cardiac muscle tissue is responsible for involuntary heart contractions. Intercalated discs help relay signals from cell to cell and synchronize heart contraction. Cardiac muscle tissue is only found in the wall of the heart.



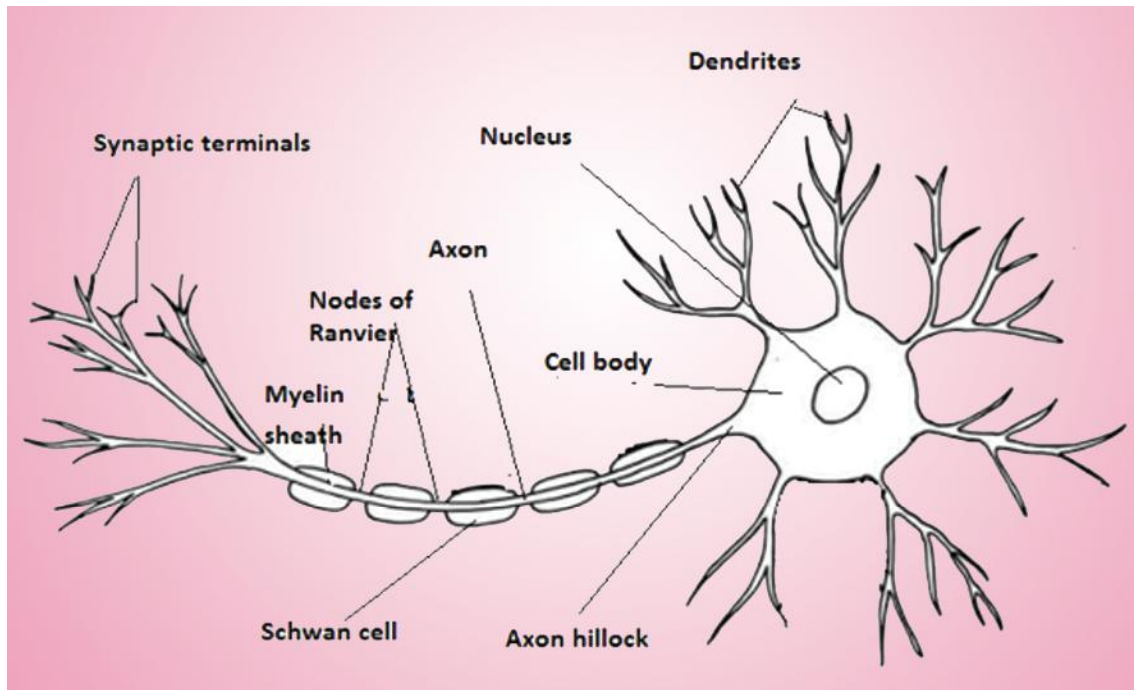
*Fig 5.6: Muscle tissue*

## 4. Nervous tissue

Nervous tissue contains neurons and glial cells. Neurons receive, process and transmit nerve impulses. Neuroglia (Glial cells) support the neurons.

Neurons: A neuron has cell body, dendrites and axon. The basic structural unit of the nervous system is the neuron. Dendrites and cell body is used to receive nerve impulses from other neurons. Axon is used to transmit impulses to other neurons, cells or muscles. Axons are bundled together into nerves.

Neuroglia (Glial cells): Neuroglial cells are supportive cells of neurons. Their functions include nourishment of nerve cells, insulation of nerve cells, replenishing neurons and sometimes modulate neuron functions.



*Fig 5.7: The structure of the Motor neuron*

## Nutrition in animals

Animal nutrition is the process by which food is taken in for make use in different body functions. Typically food is broken into smaller molecules and absorbed prior to utilization. Animals are heterotrophs.

Heterotrophic nutrition is the process by which the organisms obtain organic food molecules by ingesting other organisms or by substances derived from other organisms. Other than animals, fungi and majority of bacteria are heterotrophs. There are two type of heterotrophic nutrition namely, holozoic nutrition and symbiosis.

### Holozoic nutrition

Most animals are holozoic where they ingest food into their alimentary canal. This mode of nutrition consists of five main stages: Ingestion, digestion, absorption, assimilation and elimination/ Egestion.

### Main stages in holozoic nutrition

- **Ingestion:** This is the first stage where the act of eating or feeding happens. Food sources differ among animal species and they possess different modes of ingestion according to the diet or environment.
- **Digestion:** Food is broken down into molecules small enough to pass through the membranes and enter the cells of organisms. Digestion could occur mechanically (by teeth or muscle contractions) and chemically (by enzymes). During mechanical digestion, food is broken down in to smaller fragments thus increase the surface area for efficient chemical digestion. During chemical digestion enzymes break bonds in large molecules into small molecules.

The last two stages of food processing occur after the food is digested.

- **Absorption:** In this stage, the animal's cells take up small molecules. e.g. simple sugars, amino acids
- **Assimilation:** Assimilation is the process of utilization of absorbed nutrients for various functions of the body.
- **Elimination:** In this process undigested materials are passed out from the alimentary canal.

### Feeding Mechanisms of animals

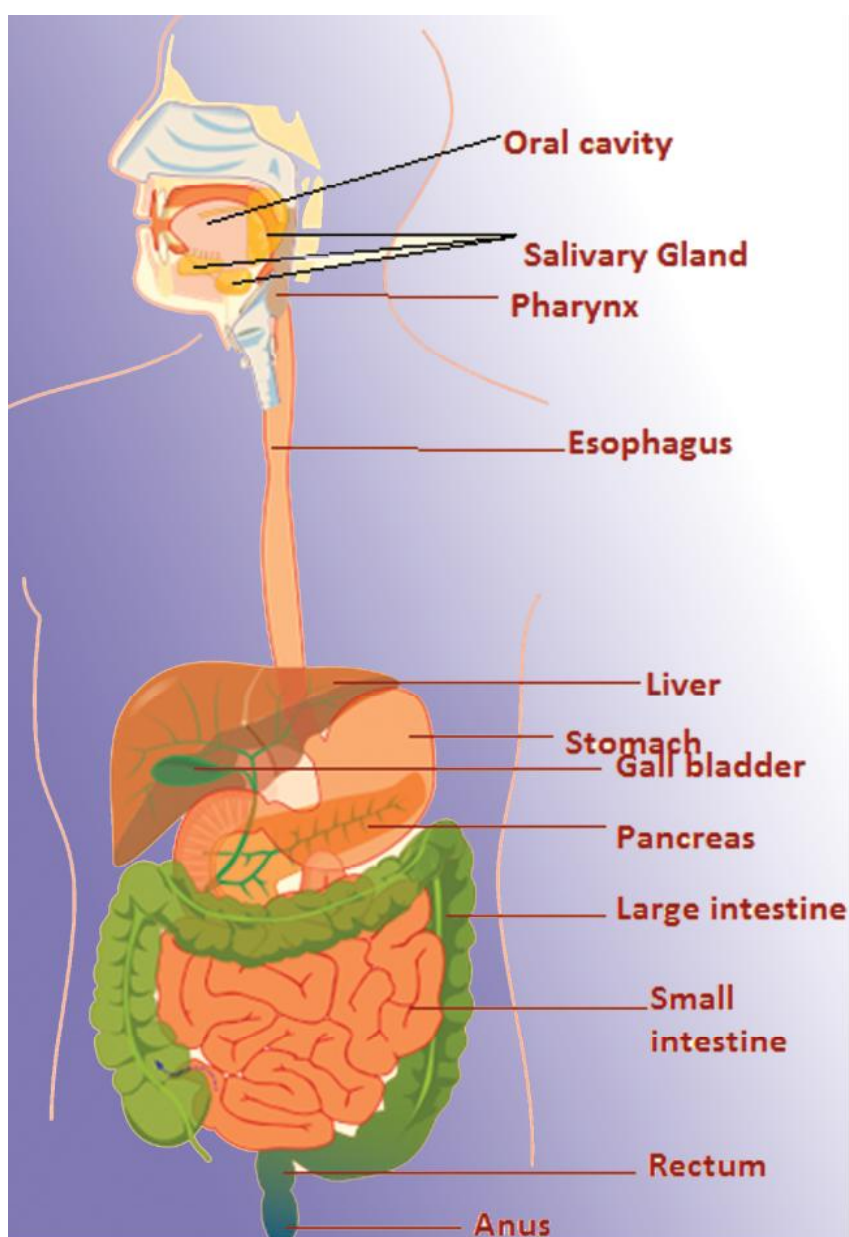
- **Filter feeders:** They strain suspended food particles from the surrounding watery medium. They use several mechanisms such as capturing, trapping, etc. e.g. - clams and oysters - feed on small pieces of food in the water that passes over their gills. Cilia in the gills sweep the food particles to the animal's mouth in a film of mucus.

- **Fluid feeders:** They suck nutrient rich fluid from a living host using well adapted mouth parts.  
e.g: Mosquitoes-suck human blood, Aphids- suck phloem sap of plants, Bees and humming birds suck -honey from flowers
- **Substrate feeders:** These animals live inside their food source or on the food source eating its way through the food.  
e.g. The leaf miner caterpillar - eating through the soft tissues of a leaf  
Maggots (fly larvae) - burrow into animal carcasses
- **Bulk feeders:** Animals which eat comparatively large pieces of food. These animals have different types of adaptations to tear the food or to capture the prey (e.g. jaws, teeth, tentacles, claws, poisonous fangs ).  
e.g. - Most animals including human
  
- **Symbiosis**  
This is an ecological relationship between organisms of two different species that live closely together. It is divided into three groups such as Mutualism, Parasitism and Commensalism
  
- **Mutualism:** It is a close association between two living organisms of different species which benefits both partners.  
e. g. - Cellulose digesting microorganisms in Ruminants and Termites
  
- **Parasitism:** It is a close association between two living organisms of different species which is beneficial to one (parasite) and harmful to the other (host). Parasites live either within or on the host and derive its nourishment  
e.g. –Tape worm and humans, Lice and humans
  
- **Commensalism:** It is a close association between two living organisms of different species which is beneficial to one and does not affect the other (neither harmful or beneficial)  
e.g.- Barnacles attached to whales

## Human Digestive system

### Structure and function of the human digestive system

Human alimentary canal is a long tube/ tract which connects with external environment and can fulfill steps of holozoic mode of nutrition. Human digestive system consists of alimentary canal and associated glands. The alimentary canal consists of the following parts: oral cavity, pharynx, esophagus, stomach, small intestine, large intestine, rectum and anus. The associated glands include salivary glands, pancreas and liver.



*Fig 5.8 :- Structure of the Human Digestive tract*

**Mouth/ Oral cavity:** Oral cavity consists of the tongue, teeth and salivary glands. Ingestion and initial steps of digestion are carried out in the oral cavity. In the mouth both mechanical and chemical digestion is carried out. There are four types of teeth in the mouth: incisors, canines, premolars and molars. Food is cut, mashed and ground by different types of teeth with different shapes. This makes it easier to swallow food and increase the surface area for digestion.

Salivary glands release saliva into the oral cavity through ducts. Releasing saliva into the oral cavity occurs when food enters the oral cavity due to a nervous reflex. Saliva is also released into the mouth before food is ingested due to various other stimuli. e.g. sight, odor of food, etc.

Saliva contains water, amylase, mucus (a viscous mixture of salts, cells and slippery glycoprotein called mucins). In addition to that, saliva composed of buffers and anti microbial components.

#### **Functions of the saliva**

- Salivary amylase: Chemical digestion of polysaccharides (e.g. starch) into smaller polysaccharides and disaccharide maltose.
- Water: Liquefy food and provide watery medium for chemical digestion. Aids in taste reception.
- Mucus: Lubrication of food which makes it easier for swallowing. Clean the mouth and protects the lining of the mouth from abrasion.
- Antimicrobial substances such as immunoglobulin and lysozymes: Protect against bacteria that enter the mouth.
- Buffers prevent tooth decay by neutralizing acid

**Tongue:** composed of skeletal muscles. Helps to mix the food with saliva and make bolus of food that makes easier for swallowing. Then helps to push the bolus into the posterior part of the oral cavity and into the pharynx.

**Pharynx:** a common passage of the respiratory tract and the digestive tract. The pharynx leads to the esophagus.

#### **Esophagus:**

It is a long tube which connects the pharynx and the stomach. It is found in the thoracic cavity. The wall of the esophagus consists of both skeletal and smooth muscles. The skeletal muscles are located towards the uppermost part of the esophagus and these muscles function during swallowing. The rest of the esophagus consists of smooth muscles which are involved in the process called peristalsis. During this process the food bolus is pushed along the esophagus which is a alternative wave of rhythmic contractions and relaxations of the smooth muscles lining the esophagus.

**Stomach-** The stomach is a J- shaped dilated sac in the abdominal cavity. The inner surface of the stomach is highly folded and contains large number of pits that leads to gastric glands. Gastric glands contain three types of cells: mucus cells, chief cells and parietal cells. The stomach wall is very elastic. Distal part of the stomach connects with the small intestine. Sphincters are found at the junctions between esophagus and stomach (cardiac sphincter) and stomach and the small intestine(pyloric sphincter). They are made up of circular smooth muscles. These sphincters help to regulate the passage of materials between these organs.

### **Chemical digestion in the stomach**

The gastric glands of the stomach secrete gastric juice. The gastric juice mainly consists of mucus, pepsinogen and HCl. Mucus and pepsinogen (inactive form of pepsin ) are secreted by mucous cells and chief cells respectively. The parietal cells release hydrogen ions and chloride ions separately into the stomach lumen where HCl is formed. Pepsinogen is initially converted into pepsin by HCl. These activated pepsin help to activate remaining pepsinogen molecules. This activated pepsin initiates the chemical digestion of proteins in the stomach. The churning action of the stomach facilitates the chemical digestion. This is a series of muscle contraction and relaxation. This process mixes the swallowed food with gastric juice. Proteins are hydrolyzed to small polypeptides by pepsin. In the stomach food is mixed with gastric juice forming chyme (partially digested semisolid, acidic, food mass).

The stomach lining is protected from the digestion of HCl and pepsin in several ways: Enzymes are secreted in to the lumen as an inactive enzyme; Gastric glands secrete mucus that protect against self-digestion of the stomach lining ; Every three days, cell division adds a new epithelial cell layer which replaces the destroyed/ damaged cells in the lining of the stomach.

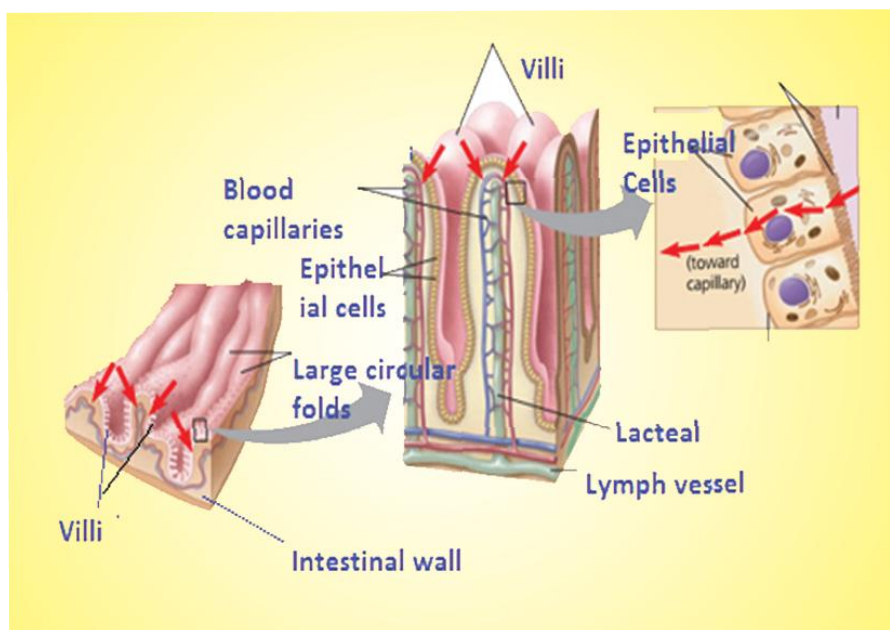
### **Functions of the stomach**

- Act as a temporary reservoir for food due to high convolution and very elastic wall.
- Mechanical digestion of food by churning action due to muscular contraction.
- Produce gastric juice which starts the chemical digestion of proteins to polypeptide by pepsin
- Absorption of some materials such as water, alcohol and some drugs
- Non specific defense-HCl kills microbes
- Small jets of gastric contents push out through pyloric sphincter as chyme
- Secretion of gastrin hormone which regulates digestion in the stomach.



### Small intestine-

It is the longest organ in the alimentary canal. It is divided into three regions: duodenum, jejunum and ileum. The duodenum: C shaped curve, around the head of the pancreas. The jejunum is middle part of the small intestine. The ileum is the terminal part of the small intestine. The surface area of the small intestine is greatly increased by permanent circular folds and villi. The villi are tiny finger like projections of the intestinal wall. Most of the digestion is completed in the duodenum. The major sites for nutrient absorption are jejunum and ileum.



*Fig 5.9 Structure of the villus*

### Chemical digestion in the small intestine

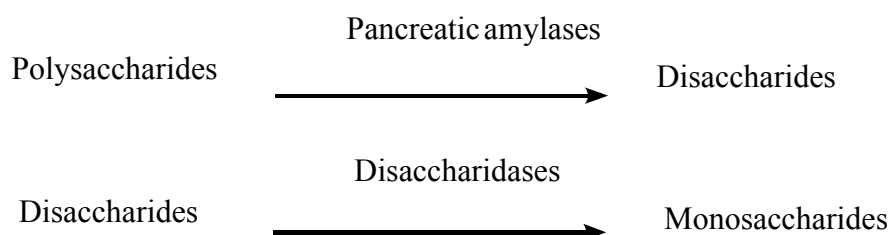
Small intestine receives chyme from the stomach. Peristaltic contractions aid the receiving of this chyme. Pyloric sphincter regulate the passing of chyme into the small intestine. The chyme is mixed with secretions of glands in intestinal wall and secretions of pancreas and liver. (refer pages no: 169,170). The epithelium of the duodenum secretes several digestive enzymes. Glands of the intestinal wall secrete enzymes such as Disaccharidases, Dipeptidases, Carboxypeptidases, Aminopeptidases, Nucleotidases, Nucleosidases and Phosphotases. Some of these enzymes are secreted to the lumen and others are bound to the surface of the epithelium.

Two hormones namely cholecystokonin and secretin secreted by duodenum stimulates the release of pancreatic juice and the bile. Pancreatic juice contains enzymes such as Trypsin, Chymotrypsin, Pancreatic amylase, Pancreatic Carboxypeptidases, Pancreatic Nucleases and Pancreatic Lipases. In addition it also contains bicarbonates. The liver secretes Bile which is stored in the gall bladder until released into the duodenum.

The Bile contains Bile salts which act as emulsifiers that help in fat digestion and absorption.

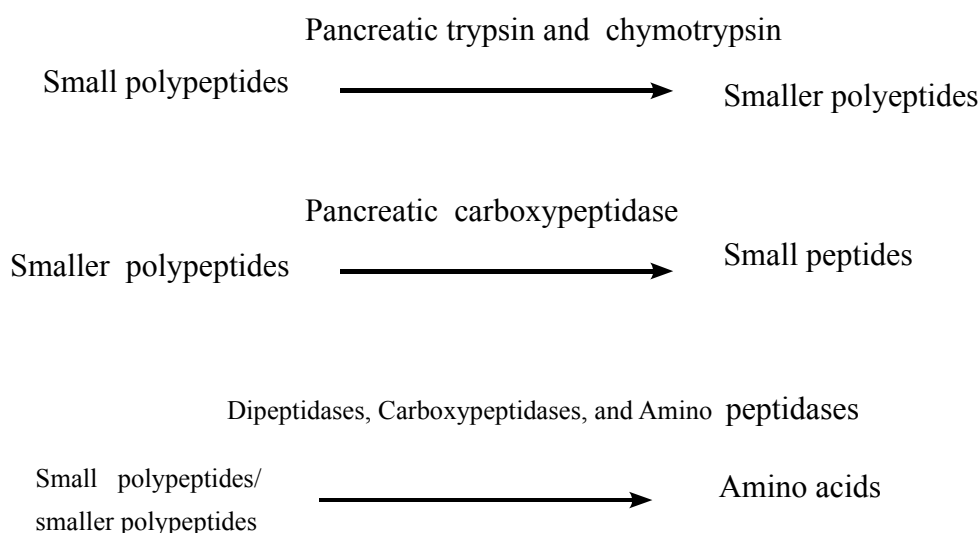
### Carbohydrate digestion

Pancreatic amylase catalyze the conversion of polysaccharides (e.g. starch) into disaccharides. Intestinal disaccharidases catalyze the conversion of disaccharides into monosaccharides.



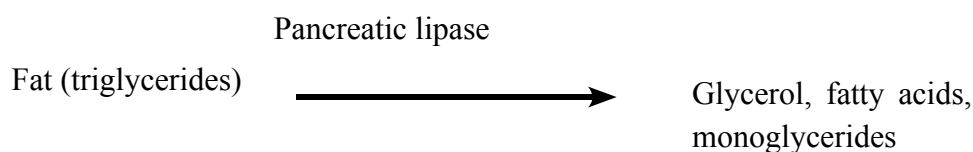
### Protein digestion

Trypsin and Chymotrypsin catalyse the conversion of small polypeptides into smaller polypeptides. These smaller polypeptides are converted to small peptides and amino acids by the catalytic action of Pancreatic carboxypeptidases. Proteases secreted by the intestinal epithelium (Dipeptidases, Carboxypeptidases and Aminopeptidases) catalyse the conversion of small peptides into amino acids.



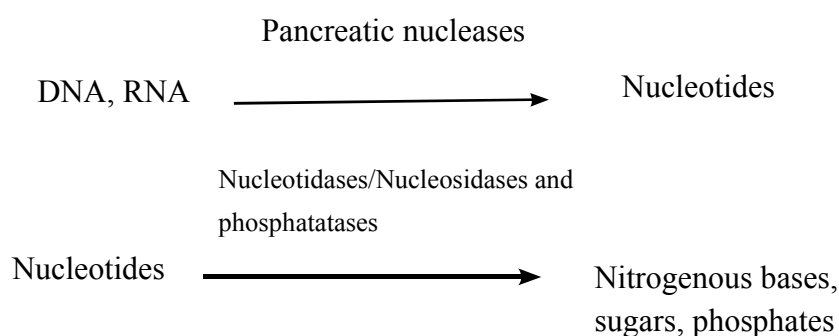
### Fat digestion

Digestion of fats (triglycerides) starts in the small intestine. First bile salts emulsify fats. Next Pancreatic lipase catalyse the conversion of these fats into fatty acids, glycerol and monoglycerides.



### Nucleic acid digestion

Digestion of nucleic acids start in the small intestine. Pancreatic nucleases catalyse the conversion of DNA and RNA into nucleotides. These nucleotides are eventually converted into nitrogenous bases, sugars and phosphates by the catalytic action of intestinal Nucleotidases, Nucleosidases and Phosphatases.



### Absorption in the small intestine

- For effective absorption, the surface area of the intestinal wall has been increased with three structural modifications: heavy permanent foldings, finger like projections called villi in the intestinal wall and finger like microscopic projections called microvilli in the epithelial cells of the villi. These micro villi are exposed into the intestinal lumen, it gives the appearance of brush (brush border).
- Transport of the nutrients across the epithelium may be active or passive. For example Fructose is absorbed by facilitated diffusion. Amino acids, small peptides, vitamins, and most glucose molecules are actively transported into the epithelial cells.
- Then these nutrients from the epithelial cells are transported into the blood capillaries in the villi. Those blood capillaries are converged into the hepatic portal veins. These nutrients are carried in to the liver via the hepatic portal veins. From the liver, this nutrient filled blood is transported into the tissues.
- But absorption of some products of fat digestion takes place in a different pathway: Fatty acids and monoglycerides are absorbed into the cell through microvilli. Within the cells triglycerides are reformed and they are incooperated into water soluble globules called chylomicrons. These chylomicrons are transported into the lacteal and then into the blood vessels through lymph. Then they are transported throughout the body via the circulatory system.

- In addition to nutrient absorption, recovery of water and ions mostly occur in the small intestine. In addition to the water intake (about 2 L) digestive juices add more water (about 7 L) into the small intestine. Most of this water is reabsorbed via osmosis.

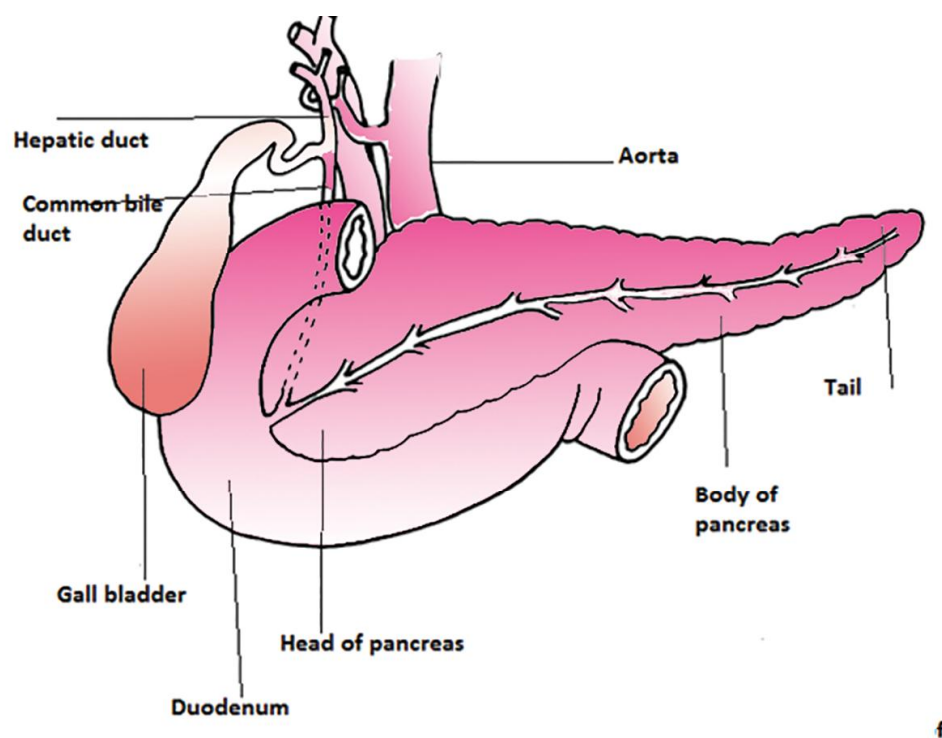
**Large intestine** – The large intestine is the terminal end of the alimentary canal. It is divided into three regions: colon (proximal part), cecum and rectum. The small intestine is connected to the large intestine at a ‘T’ shaped junction. One arm of the ‘T’ junction is colon and the other arm is a small pouch called cecum. A finger like projection in the cecum is called the appendix. The colon leads to the rectum and anus. Cecum is important for fermentation of indigested materials by microbes, especially in animals that eat large amount of plant matter.

### Functions of the large intestine

- The colon: completes the reabsorption of water, synthesize some Vitamin B complexes, Vitamin K and folic acid with the help of microbes and move feces (consists of undigested matter such as fibres) along the colon by peristalsis.
- The rectum stores feces until they are eliminated. Presence of two sphincters between the rectum and anus can regulate feces movement. Strong contractions in the colon trigger the defecation.

### Associated glands

#### Pancreas



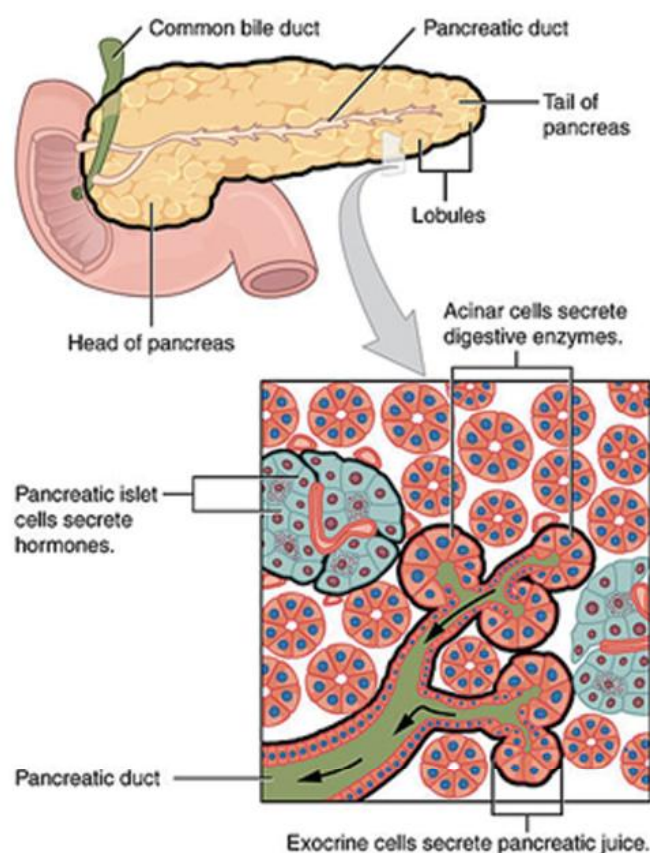
*Fig 5.10: The pancreas in relation to the duodenum and biliary tract*

## Histological structure of pancreas

The pancreas is a pale grey gland which consists of a broad head, a body and a narrow tail. Head is in the curve of the duodenum. Pancreas is both an exocrine and endocrine gland.

The exocrine part consists of a large number of lobules made up of small acini, the walls of which consist of secretory cells. Each lobule is drained by a tiny duct and these unite eventually to form the pancreatic duct which joins with bile duct to form hepato pancreatic duct and opens into the duodenum at its midpoint. Exocrine part of the pancreas secretes pancreatic juice. The components of the pancreatic juice are bicarbonate, carbohydrate digesting enzymes (pancreatic amylase), pancreatic lipase, nucleases and inactive form of protein digesting enzymes (trypsinogen and chymotrypsinogen). These inactive enzymes are converted to active enzymes (trypsin and chymotrypsin) upon secretion into the lumen of the duodenum.

Endocrine part of the pancreas is the islets of Langerhans, which consist of group of specialized cells. They do not have ducts. Islets of Langerhans secrete hormones, glucagon and insulin which are involved in glucose homeostasis.

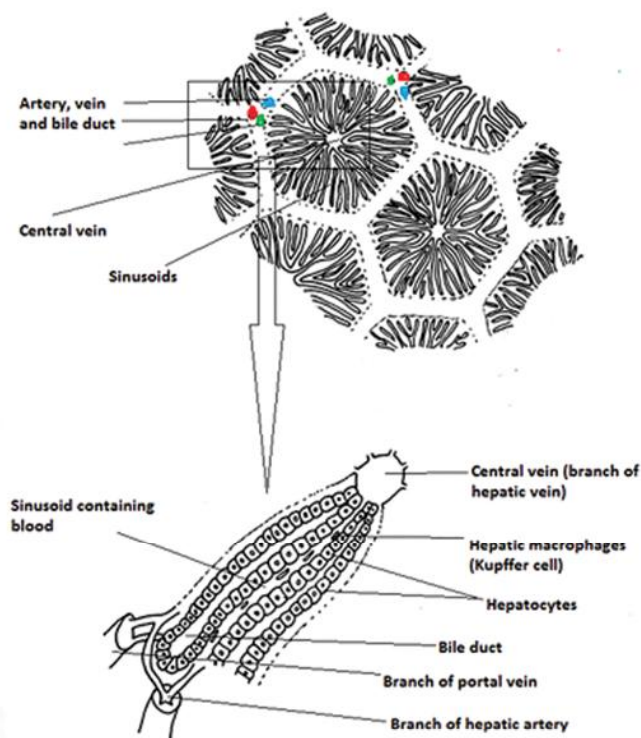


**Fig 5.11: Histological structure of the pancreas**

## Liver

Liver is the largest gland in the body. Its upper and anterior surfaces are smooth and convex. Its posterior surface is irregular in outline. Liver contains four lobes. Each lobe is made up of tiny hexagonal shape lobules which are the functional unit. These lobules are made up of cuboidal cells called hepatocytes which are arranged in pairs of columns radiating from a central vein. Between two pairs of column of cells there are sinusoids (blood vessels with incomplete walls) containing mixture of blood from the tiny branches of the portal vein and hepatic artery. This arrangement allows venous blood (high concentration of nutritional materials) to mix with arterial blood and come into close contact with liver cells. Hepatic macrophages (Kupffer cells) are found in the lining of the sinusoids. Blood drains from the sinusoids into central veins which joins with veins from the other lobules, forming larger veins and eventually the hepatic vein. (fig 5.12). Bile canaliculi run between columns of liver cells. Canaliculi join up to form larger bile canals. In the corner of the hexagonal structure a branch of hepatic artery, a branch of the hepatic portal vein and intra lobular bile duct can be found.

Liver is a vital organ that performs many important functions. In addition to its role in food digestion it is also perform functions such as metabolism of carbohydrates, fats and proteins, detoxification of drugs and toxic substances, defense against microbes, some hormone inactivation and heat production.



**Fig 5.12: Histological structure of the liver**

**Function of liver related to digestion**

The liver secretes bile which is stored in the gall bladder until released into the duodenum. The bile contains bile salts which act as emulsifiers that help in fat digestion and absorption.

Most of the absorbed nutrients reach the liver and it regulates the distribution of nutrients to the rest of the body. Excess glucose is stored as glycogen in the liver cells. Glycogen deposition and break down in the liver cells are regulated by insulin and glucagon hormones. Fat soluble Vitamins (A,D,E and K) and some water soluble vitamins (B12), iron and copper are also stored in liver.

**Regulation of digestion in man**

Digestion in man is regulated by two ways: nervous regulation and endocrine regulation. Nervous regulation is mainly by nervous reflexes. For example nervous reflex stimulates the release of saliva when food reach the mouth. Arrival of food in the stomach trigger churning and release of gastric juices. Endocrine system plays a critical role in digestion especially in the stomach and small intestine.

when food arrives the stomach, the stomach wall is stretched. This triggers to release the hormone gastrin. Gastrin circulates via the blood stream and arrives the stomach. Then gastrin stimulates the production of gastric juice at the stomach.

Fatty acids and amino acids in the chyme trigger the release of Cholecystokin and Secretin from the duodenum. Cholecystokin triggers release of bile from the gall bladder and digestive enzymes from the pancreas. Secretin stimulates the release of bicarbonate from the pancreas. Bicarbonate neutralize the chyme received from the stomach

When the chyme is rich in fat, food digestion in the stomach slows down due to high levels of Cholecystokin and Secretin secreted by duodenum. These hormones act on the stomach and inhibit peristalsis and gastric juice secretion.

**Balanced Diet**

The balanced diet contains the all essential nutrients required for health in the appropriate proportions. Essential components of the balanced diet contain carbohydrates, proteins, lipids, fibers, minerals, vitamins and water. Carbohydrates and lipids supply energy. Energy requirements vary with age, sex, body size and activity. Twenty amino acids are needed to synthesize proteins in the body. Most of these amino acids are synthesized within the body. They are known as non essential amino acids (e.g. Alanine, cystine, etc). Other amino acids (e.g. lysine and histidine, etc.) must be obtained from the diet as they can't be synthesized within the body. They are called essential amino acids. Animal proteins contain all the essential amino acids in proper proportions. However most plant proteins lack one or more essential amino acids. Therefore vegetarian based diet requires several sources of plant proteins to obtain all the essential amino acids.

**Components of foods and their functions**

- Carbohydrates
- Proteins
- Lipids
- Vitamins
- Mineral elements
- water
- fibers

**Carbohydrates**

Carbohydrates are sugars and polysaccharides. They can be found in a variety of foods such as rice, bread, biscuits, cereals, hoppers, etc. during digestion most carbohydrates are broken down into monosaccharides which are absorbed into blood stream.

**Functions of digestible carbohydrates**

- Provide energy and heat: breakdown of carbohydrates provides ATP for body functions and generates heat.
- Act as an energy stores. e.g. excess carbohydrates are converted into glycogen and fat
- Facilitates protein sparing- proteins are not used to get energy when there is an adequate carbohydrates in the food

**Proteins**

Proteins are made up of amino acids during the digestion, proteins are broken down into amino acids and absorbed into the blood stream.

The amino acids are grouped into two groups i.e. essential amino acids and non essential amino acids. These essential amino acids cannot be synthesized in the body, therefore they should be obtained into the body through the diet. The non essential amino acids can be synthesized within the body. Therefore it is not necessary to obtain them through the diet.

**Functions of proteins in the diet**

- The amino acids which are supplied from proteins
  - are used for growth and repair of body cells and tissues
  - are used for synthesis of plasma proteins, enzymes, antibodies and some hormones
- Act as an energy source for body functions



**Lipids**

Lipids in the diet are mainly composed of fats and oils. Fatty acids are composed of fats and oils. Fatty acids can be grouped as essential and non essential fatty acids. Essential fatty acids cannot be synthesized within the body while the non essential fatty acids can be synthesized within the body. Therefore essential fatty acids should be obtained through the food.

**Functions of lipids in the diet**

- Provide energy and heat (on weight basis fats and oils provide more energy compared to carbohydrates and proteins)
- Help in transport and storage of fat soluble vitamins such as Vitamin A, D, E and K
- Store energy as fat in the adipose tissues
- Help to synthesize steroid hormones from cholesterol.
- Provide insulation: (e.g fat found in subcutaneous layer in the skin reduces heat loss , constituents of myelin sheath of neurons)

**Vitamins**

Vitamins are organic compounds required in small amounts for the maintenance of normal health and metabolism. Vitamins cannot be produced in the body and therefore should be provided in the diet. If the vitamins are insufficiently taken into the body, that may lead to the deficiency diseases. Vitamins are two types they are fat soluble vitamins (Vitamin A, D, E and K) and water soluble vitamins (Vitamin B and C).

**Main Functions of Vitamins**

- Vitamin A- form visual pigments in the eye, epithelial tissue maintenance, promotion of growth and immunity
- Vitamin B- components of coenzymes such as FAD and NAD, promote red blood cell production
- Vitamin C- act as an antioxidant, used in collagen synthesis
- Vitamin D- aids in absorption and use of Calcium and Phosphorous
- Vitamin E- act as an antioxidant
- Vitamin K- important in blood clotting

**Minerals**

Minerals are inorganic substances and they are also important for normal health and many body functions. Major mineral elements needed by humans are Ca, P, S, K, Cl, Na, Mg, Fe, F and I . In addition minerals needed in trace amounts include Co, Cu, Mn, Mo, Se and Zn.

**Main functions of minerals include**

- Ca- form bones and teeth, helps clotting blood and nerve and muscle function
- P- form bones and teeth, help maintain in acid base balance
- S- components of some amino acids
- K- help maintain in acid base balance and water balance, nerve function
- Cl- help maintain in acid base balance, maintain osmotic balance, nerve function
- Na- help maintain in acid base balance and water balance, nerve function
- Mg- act as enzyme cofactor
- Fe- components of hemoglobin and electron carriers, act as an enzyme cofactor
- F- maintenance of tooth structure
- I- component of thyroid hormone

**Water**

Water accounts for around 60% of the body mass in humans. Normally water is lost through urine, sweating and feces. Therefore amount of water in the body should be balanced within the body. This water can be taken in to the body by drinking and via foods.

**Functions of water in human body**

- Provides the moist internal environment for all living cells.
- Major component of blood and tissue fluid therefore helps to transport materials around the body and to exchange materials between blood and tissues and body cells
- Regulate body temperature mainly through evaporative cooling
- Dilute waste products and toxins and provide a medium for their excretion
- Moistens the food and that make easier to swallow

**Fibres**

Dietary fibres (non starch polysaccharides) are made up of indigestible polysaccharides in the diet. Fibres are rich in fruit, vegetable and cereals.

**Functions of dietary fibres**

- Provide bulk to the diet and satisfy the appetite.
- Prevent constipation by attracting water to increase faecal bulk and stimulating peristalsis leading to defecation.
- Adequate fibres in the diet protect against some gastro-intestinal disorders such as cancers in the colon and rectum.

**Essential nutrients:** Essential nutrients are the substances that cannot be synthesized in the body from simple precursors and must therefore be taken through the diet. These essential nutrients include essential amino acids, essential fatty acids, vitamins and minerals. Essential nutrients have key functions in bio synthetic reaction in the body cells. If these essential nutrients are not supplied in correct proportions in the diet that will lead to malnutrition. Therefore it is essential to obtain them in correct amounts.

**Essential amino acids:** Essential amino acids are the amino acids that must be obtained from the food since they cannot be synthesized within the body from organic precursor molecules. Of the 20 amino acids required to make proteins in the body 8 amino acids are essential amino acids. Examples for essential amino acids are leucine and methionine. The animal protein products (e.g. eggs, meat, cheese, etc.) will provide all essential amino acids in correct proportions required for body functions. Most plant proteins are “incomplete” as they are deficient in one or more amino acids. Therefore vegetarian diet should contain a variety of plant proteins in order to obtain all the essential amino acids required.

**Essential fatty acids:** Essential fatty acids are the fatty acids that should be obtained from the diet since they cannot be synthesized in the body from organic precursors. Seeds, grains and vegetables provide enough amounts of essential fatty acids.

**Table : Dietary sources and deficiency symptoms of vitamins and minerals**

Vitamin/ Mineral	Main dietary sources	Deficiency symptoms
<b>Fat soluble vitamins</b>		
Vitamin A (retinol)	Dark green vegetables, orange vegetables and fruits, dairy products	Blindness, skin disorders, immunity impairment
Vitamin D	Egg yolk, dairy products	Bone deformities(rickets) in children, bone softening in adults
Vitamin E	Vegetable oils, nuts, seeds	Nervous system degeneration
Vitamin K	Green vegetables, tea, produced by colon bacteria	Defective blood clotting
<b>Water soluble vitamins</b>		
Thiamine ( Vitamin B <sub>1</sub> )	Legumes, peanuts, whole grains, pork	Beriberi(characterized by tingling, poor coordination, susceptibility to infection, reduced heart function)
Riboflavin (Vitamin B <sub>2</sub> )	Dairy products, meats, vegetables, enriched grains	Skin lesions (cracks at corners of mouth)
Niacin (Vitamin B <sub>3</sub> )	Grains, nuts, meats.	Pellagra(characterized by lesions in skin, mental confusion and diarrhea)
Pantothenic acid (Vitamin B <sub>5</sub> )	Dairy products, fruits, vegetables, grains	Fatigue, numbness, tingling of hands and feet

Vitamin/ Mineral	Main dietary sources	Deficiency symptoms
Pyridoxine (Vitamin B <sub>6</sub> )	Whole grains, Meats, vegetables	Irritability, anemia
Biotin (Vitamin B <sub>7</sub> )	Meats, legumes, vegetables	Neuro- muscular disorders, scaly skin inflammation
Folic acid (Vitamin B <sub>9</sub> )	Green vegetables, whole grains	Anemia, birth defects
Cobalamin(Vitamin B <sub>12</sub> )	Dairy products, eggs, meats	Loss of balance, numbness, anemia
Ascorbic acid (Vitamin C)	Citrus fruits, broccoli, tomatoes	Scurvy (characterized by degeneration of skin and teeth) , delayed wound healing
<b>Minerals</b>		
Calcium (Ca)	Dairy products, dark green vegetables, legumes	Loss of bone mass, impaired growth
Iron (Fe)	Whole grains, green leafy vegetables, legumes, meats, eggs	Anemia, weakness, impaired immunity
Phosphorus (P)	Rice, bread, milk, dairy products, fish, red meat	Decaying of teeth and bones, weakness
Potassium (K)	Fruits, vegetables, meat , dairy products, grains	Muscle weakness, nausea , paralysis, heart failure
Iodine(I)	Sea foods , vegetables, iodized salt	Goiter( enlarged thyroid glands)
Sulfur (S)	Foods containing proteins	Fatigue, Impaired growth, swelling
Chlorine (Cl) and Sodium (Na)	Table salt	Reduced appetite, muscle cramps
Magnesium (Mg)	Green leafy vegetables, grains	Disturbance in nervous system
Fluorine (F)	Tea, sea food, drinking water	Tooth decay

### Basal metabolic rate (BMR)

- Basal metabolic rate is defined as the minimum metabolic rate at rest, when in a post absorptive stage (at least 12 hour fasting) and is not experiencing stress.
- BMR is measured under a “comfortable” temperature range.
- BMR of humans averages for adult males 1,600-1,800 kcal per day and 1,300-1,500 kcal for adult females.

**Energy budget:** An energy budget is a balance sheet of energy intake against energy expenditure in a particular animal. The basic model of energy budget can be shown as follows;

$$C=M+U+F+P$$

Where C=Energy content in the food sources taken in

M= Energy spent for metabolic activities

U= Energy associated with urinary loss

F= Energy associated with fecal loss

P= Production (Energy available for growth and reproduction)

In energy budgets, energy content in the food intake is compared with energy expenditure which includes energy spent for basal metabolism and extra activities (M), energy associated with excretory products namely urinary loss (U) and fecal loss (F). The energy differences between the energy intake and the energy expenditure for metabolism and excretion are available for production which includes growth and reproduction. Energy budget can be calculated for each animal based on energy measurements from field and laboratory. Energy budgets are useful for estimating energy available for growth and reproduction.

**Food for healthy life:** For a healthy life diet should contain correct proportions of carbohydrates, proteins, lipids, water, fiber, essential mineral elements and vitamins. Dietary deficiencies can have negative impact on health. When food intake exceeds daily energy requirements especially in inactive individuals can lead to ill health conditions specially diabetes mellitus and heart diseases. Some individuals develop allergic reactions to foods such as pineapple, peanuts and tomatoes. Such individuals should avoid these types of foods. Antioxidants present in the food material (e.g. vitamin C and vitamin E) are also important in avoiding disorders in the alimentary canal and maintaining a healthy life. As humans cannot synthesize all the required antioxidants some of them should be obtained from the diet.

**Malnutrition:** Malnutrition can arise due to failure of obtaining an adequate nutrition when the diet lacks one or more essential nutrients or consistently supplies less chemical energy than the energy required by the body. According to the WHO if, body mass index (BMI) is less than 18.5 is said to be malnutrition. BMI of a person is calculated as follows,

$$\text{BMI} = \text{Mass} / \text{height}^2 \text{ (kg/ m}^2\text{)}$$

**Obesity:** Obesity arises when energy expenditure of a person is much less than the energy intake. According to the WHO criteria, if the BMI is at 30.0 or over it is known as obesity. This condition is a growing issue worldwide. Obesity can lead to many diseases such as diabetes mellitus, cardiovascular diseases, some cancers etc.

### **Common disorders in the alimentary canal**

**Gastritis:** gastritis is a condition resulting inflammation of the stomach which can be due to several reasons. In gastritis, glands of the stomach wall are stimulated and secrete excess HCl causing damage to the mucosa. Due to the damages of mucosa layer of the stomach, blisters can be formed. Prolonged starvation and mental stress are one of the reasons for the secretion of excess HCl. Some drugs like aspirin can also induce gastritis conditions. Longer lasting gastritis conditions is usually associated with the infection by the acid tolerance bacterium *Helicobacter pylori*. As prolonged starvation is one of the reasons for developing gastritis proper food habits should be practiced to control this condition.

**Constipation:** Constipation occurs due to the slow movement of feces that promotes the water reabsorption and as a result feces become more solid. Inhibition of the reflex action in defecation may also leads to constipation. This leads to pain in the anus and difficulty in defecating. Constipation can be controlled by developing behavioral adjustments to carry out defecation properly. Intake of adequate fiber in the diet can help prevent constipation.

## **Circulatory Systems in Animals**

### **Need of a circulatory system**

A circulatory system is required in animals for transportation of materials within the body and exchange of materials with the external environment. The simple animals (e.g. Cnidarians, Flat worms) lack specialized system for the transport and distribution of material because many or all cells are in direct contact with the external environment. In these animals exchange of materials over the body surface through direct diffusion is sufficient for their needs. In these animals those materials can be transported by diffusion through short distance within the body.

As organisms increase in size and complexity, the amount of materials moving in and out of the body also increases. The distance that materials have to be transported within the body also increases and many cells are not in direct contact with their external environment. Therefore diffusion is not sufficient to transport materials throughout the body. Therefore circulatory systems have evolved in such organisms to exchange materials between cells and their immediate surroundings.

### **Substances that are transported in the body**

Substances that are transported in the body include respiratory gases (oxygen, carbon dioxide), nutrients (glucose, amino acids, fatty acids, vitamins, etc.), waste products of metabolism (urea, ammonia, etc), hormones and antibodies.

## Blood circulatory systems in the animal kingdom

A circulatory system has three basic components: a muscular pumping device (heart), interconnected vessels and a circulatory fluid (blood/ hemolymph). Circulatory fluid flows through the vessels mainly due to the pressure generated by the heart. The circulatory system functionally connects the fluid environment of the body cells to the organs that exchange gases, absorb nutrients and dispose of wastes by transporting fluids throughout the body. Various degrees of complexity in the arrangement of circulatory systems can be seen in the animal kingdom.

### Main circulatory systems in the animal kingdom

There are two types of circulatory systems among the animals: open circulatory system and closed circulatory system.

**The open circulatory system:** It is a circulatory system in which a fluid called hemolymph that bathes the tissues and organs directly. There is no distinction between the circulatory fluid and the interstitial fluid surrounding cells. The heart pumps hemolymph through the circulatory vessels into the spaces (interconnected sinuses) which surround body tissues. Chemical exchange occurs directly between the hemolymph and body cells. Back flow of the hemolymph takes place via the pores (ostia) with valves found in the heart during the relaxation. The open circulatory system has evolved in some invertebrate phyla such as Arthropoda and Mollusca (some mollusc groups).

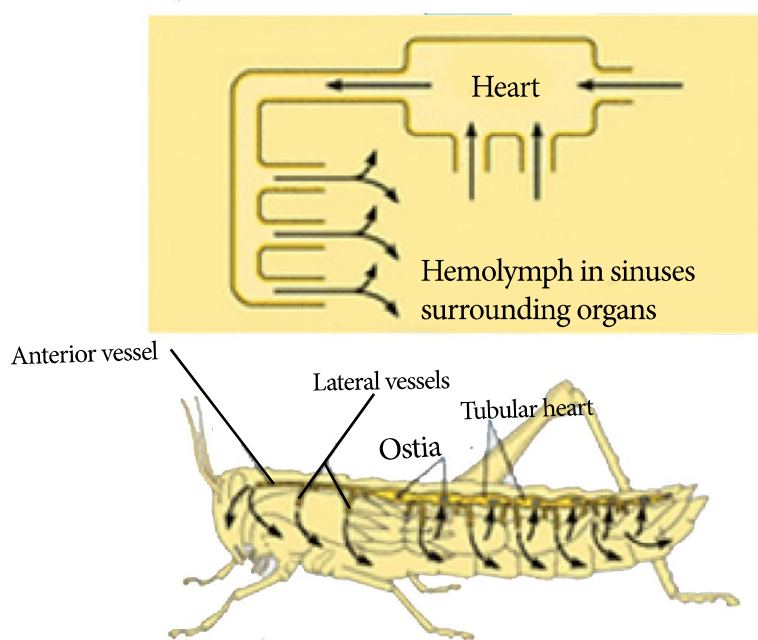
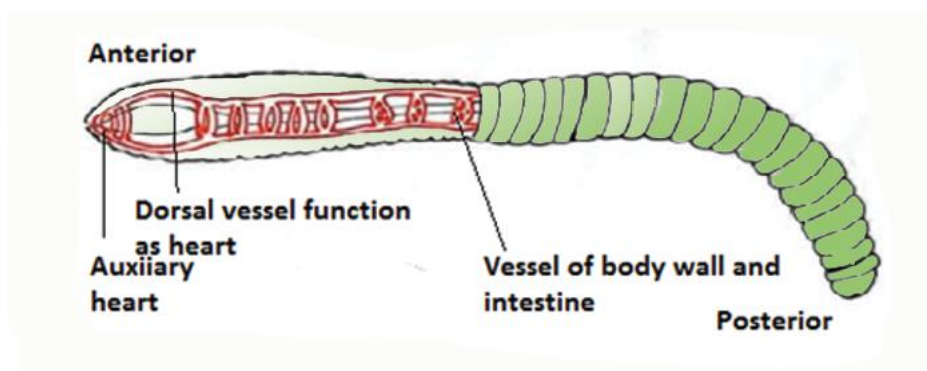


Fig 5.13: Circulatory system of a Grass hopper

**The closed circulatory system:** It is a circulatory system in which blood is restricted to vessels and kept apart from the interstitial fluid. Blood is pumped by the heart/s into large vessels. These large blood vessels branches into small vessels and they penetrate into the organs. Chemical exchange occurs between the blood and the interstitial fluid and interstitial fluid and body cells. It may contain one or more hearts. This type of circulatory systems can be seen in vertebrates and invertebrates such as Annelids. In comparison to open circulatory system enable effective delivery of oxygen and nutrients to the cells of larger and more active animals due to relatively high blood pressure.



*Fig 5.14: Closed blood Circulatory system of an Annelid*

### **Organization of vertebrate circulatory systems: Single circulation and double circulation**

Vertebrates have a closed circulatory system where there are three main types of blood vessels: arteries, veins and capillaries. Within each type blood flows in only one direction. The blood vessels which carry blood from the heart to organs are called arteries. When these arteries branch into smaller vessels within organs they are called arterioles. They pass blood to capillaries which are microscopic vessels with thin and porous walls. These are the places where materials exchange occurs between blood and interstitial fluid surrounding body cells through diffusion. Capillaries converge into venules and they converge into veins which carry blood back to the heart.

#### **Single circulation**

During single circulation, in a complete circulation through the entire body, blood passes through the heart only once. In animals that demonstrate single circulation, possess two chambers in the heart. They are atrium and ventricle.

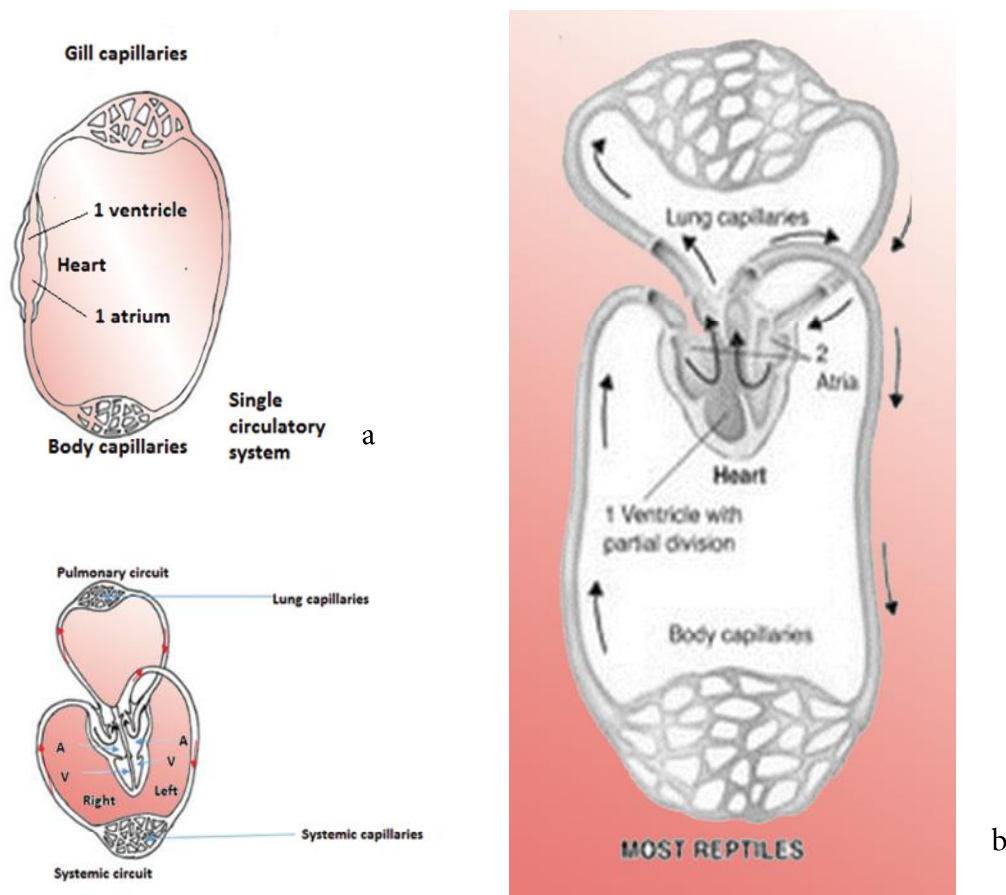
During a single circulation, the oxygen poor blood returning from the body enters atrium and pass into the ventricle. Then the ventricle is contracted, blood is pumped into the capillary bed in the gills. There gas exchange occurs between the capillaries and the external environment. The  $O_2$  is diffused into the blood while  $CO_2$  is removed from the blood. Next the oxygen enriched blood circulates throughout the body and reaches the body cells through body capillaries. e.g.: Bony fishes, Cartilagenous fishes such as rays and sharks.



### Double circulation

During double circulation, in a complete circulation through the entire body, blood passes through the heart twice. Such circulatory system consists of separate pulmonary and systemic circuits in which blood passes through the heart after completing each cycle. e.g. Amphibians, Reptiles, Aves, Mammals. Amphibians and most reptiles have a three chambered heart: two atria and one ventricle. Birds and mammals have a four chambered heart where heart is completely divided into left and right sides. This arrangement allows the complete separation of oxygen enriched and oxygen poor blood. The oxygen poor blood from systemic circulation flows to the right atrium of the heart and then to the right ventricle. Right ventricle pumps blood into the lungs. Oxygen enriched blood from the lungs reaches the left atrium and pass to the left ventricle. The left ventricle pumps oxygen enriched blood into the systemic circulation.

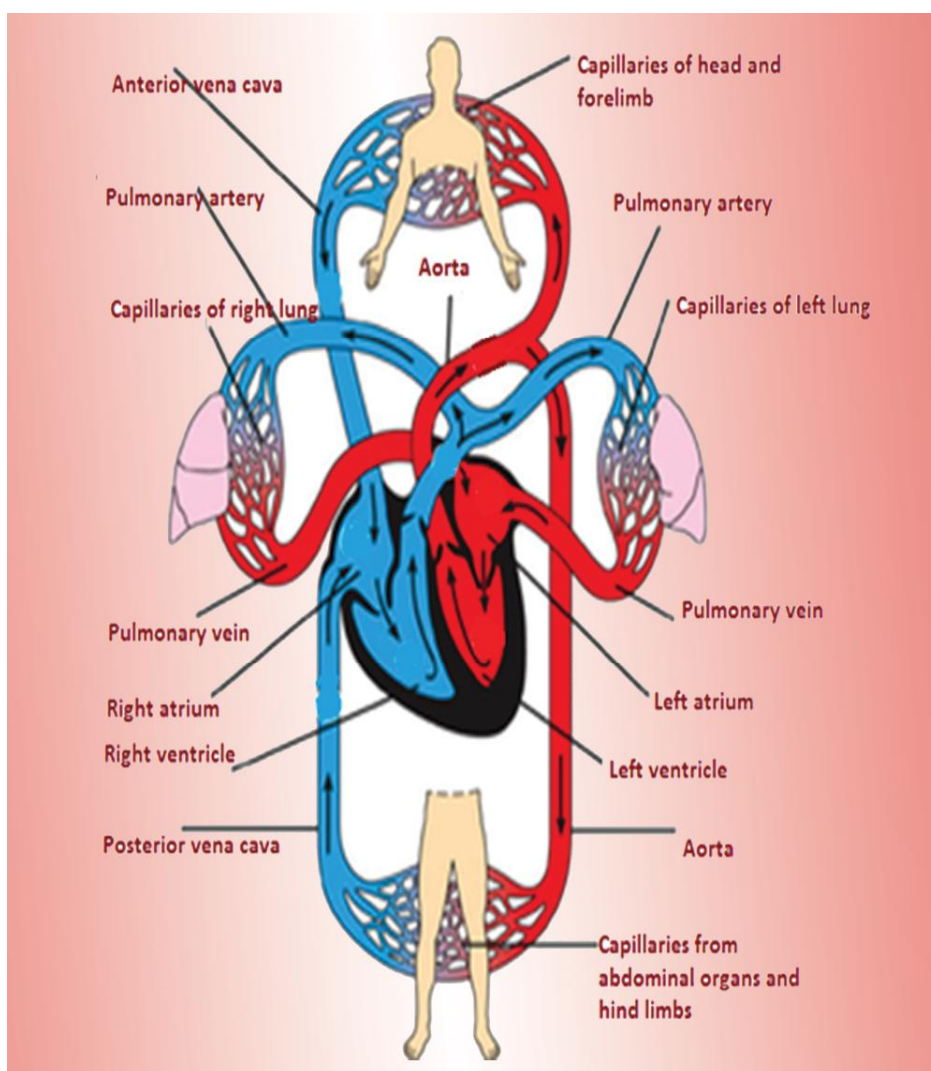
Double circulation is more effective in supplying blood to all body organs and tissues especially brain and muscles due to the higher pressure exerted by the heart in the systemic circulation. This in contrast to single circulation where blood flows under reduced pressure from the gas exchange organs to other organs.



**Fig 5.15: Single and double circulatory systems in animals: a. Single circulation (fish), b. double circulation (amphibian) c. double circulation (mammal)**

## Basic plan of human blood circulatory system and lymphatic system

### Basic plan of human blood circulatory system



**Fig 5.16: Basic plan of the human blood circulatory system**

Figure (5.16) depicts the basic plan of the human blood circulatory system. The human heart consists of four chambers; they are two ventricles and two atria. There is a dual circuit which operates simultaneously. The pulmonary circuit takes oxygen poor blood to the respiratory surface, the lungs and returns the oxygen enriched blood back to the heart while the systemic circuit supplies oxygen enriched blood to all organs and tissues in the body and returns oxygen poor blood from organ and tissues back to the heart. Each circuit consists of major arteries/arteries, arterioles, capillary beds, venules and veins/major veins.

During ventricular contraction, the right ventricle pumps the oxygen poor blood into the two lungs via the pulmonary arteries. Then in the lungs  $O_2$  is loaded into the blood through diffusion while  $CO_2$  is unloaded from blood into the external environment.

This process occurs in the capillary beds in the left and right lungs. Then the oxygen rich blood is transported into the left atrium via the two pulmonary veins. During atrial contraction, this oxygen rich blood is transported into the left ventricle. During ventricular contraction oxygen rich blood is pumped into the aorta. Through arteries the aorta conveys this oxygen rich blood throughout the body. First the aorta branches into the coronary arteries which supplies blood into the heart muscles. Then the aorta branches into arteries, arterioles leading to capillary beds in the head and arms and the capillary beds in the abdominal organs and legs. The exchange of gases occurs in the capillary beds where O<sub>2</sub> rich blood is diffused into the tissues while the CO<sub>2</sub> rich blood diffused into the blood capillaries. These blood capillaries rejoined to form venules which direct oxygen poor blood into veins. Oxygen poor blood from trunk and hind limbs is drained into the inferior vena cava and oxygen poor blood from the head, neck and fore limbs are directed into the superior vena cava. The blood from both inferior and superior vena cava is pumped into the right atrium where it is passed into the right ventricle. This blood is directed to the pulmonary circuit as explained above.

### **Basic plan of human lymphatic system**

The lymphatic system is closely connected with the blood circulatory system both structurally and functionally. It consists of lymph vessels through which lymph travels. Other structure in the lymphatic system includes lymph nodes, lymphoid tissues (tonsils) and lymphoid organs (e.g. spleen and thymus). Lymph vessels consist of tiny vessels and larger vessels. Tiny lymph vessels are in close contact with the capillaries of the blood circulatory system. Lymph nodes are composed of connective tissues and white blood cells.

The lymphatic system returns lost fluid and proteins from the blood capillaries back into the blood. The lost fluid from the blood capillaries is called lymph when they are inside the lymphatic system. The composition of the lymph is same as interstitial fluid. Lymph vessels have valves. That prevents the backflow of the lymph. The lymph is drained into veins at the base of the neck via two large ducts. The rhythmic contraction of the lymph vessel walls and skeletal muscle contraction help to move the lymph.

The functions of human lymphatic system include tissue drainage to maintain the blood volume in the blood circulatory system, absorption of fat and fat soluble vitamins from the small intestine and for immune responses.

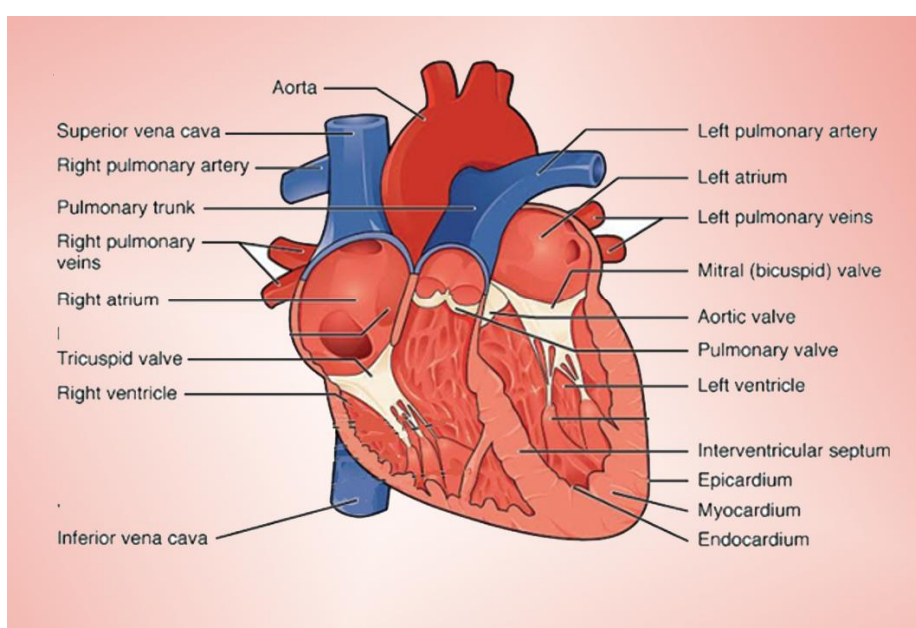
### **Structure and function of the human heart**

The human heart is roughly a cone shaped hollow muscular organ. The heart wall is composed of three layers of tissues: Pericardium, Myocardium, Endocardium.

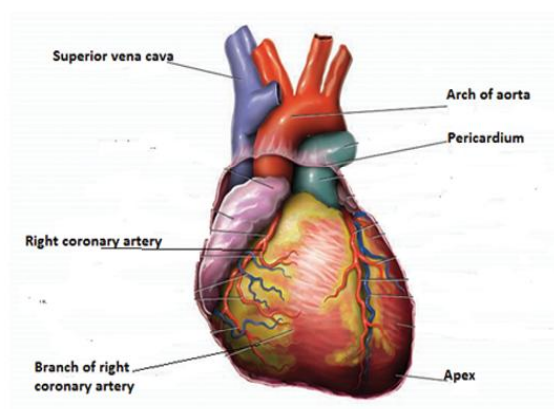
**Pericardium:** The pericardium is the outer most layers. It is made up of two sacs: The outer fibrous pericardium and inner serous pericardium.

**Myocardium:** Myocardium is the middle layer of the heart wall. It is composed of specialized cardiac muscle found only in the heart. Running through the myocardium is also a network of specialized conducting fibres responsible for transmitting the heart's electrical signals.

**Endocardium:** Endocardium is the inner layer of the heart wall. It lines the chambers and valves of the heart. It is a smooth membrane and consists of flattened epithelial cells. It is continuous with the endothelium lining of the blood vessels.



**Fig 5.17: Interior of the human heart**



**Fig 5.18: External appearance of the human heart**

There are four chambers in the heart two upper atria and two lower ventricles. Ventricles have to pump blood to the whole body where as atria pump blood to the ventricles only. Therefore walls of the ventricles are thicker than walls of the atria. Wall of the left ventricle is thicker than walls of the right ventricle because the right ventricle pumps blood to the lungs which are closer to the heart whereas the left ventricle has to pump blood throughout the body.

Therefore the blood entering the aorta from the left ventricle is at much higher blood pressure than the blood entering the pulmonary artery from the right ventricle.

The heart is completely divided into a right and left side by a septum. The atria and ventricles on each side are divided by an atrio-ventricular valve (AV). The right atrioventricular valve has three flaps hence known as tricuspid valve and the left atrioventricular valve has two flaps hence known as bicuspid valve. Conical shaped papillary muscles are extensions of the inner wall of the ventricles. Atrio-ventricular valves attached to the papillary muscles by fibrous cords which are called chordae tendineae. Atrio-ventricular valves are anchored by strong fibres. This prevents the valves from being turned inside out. Semilunar valves are found at the points where the pulmonary artery and aorta leave the right and left ventricles respectively. These valves prevent the backflow of blood into the ventricles.

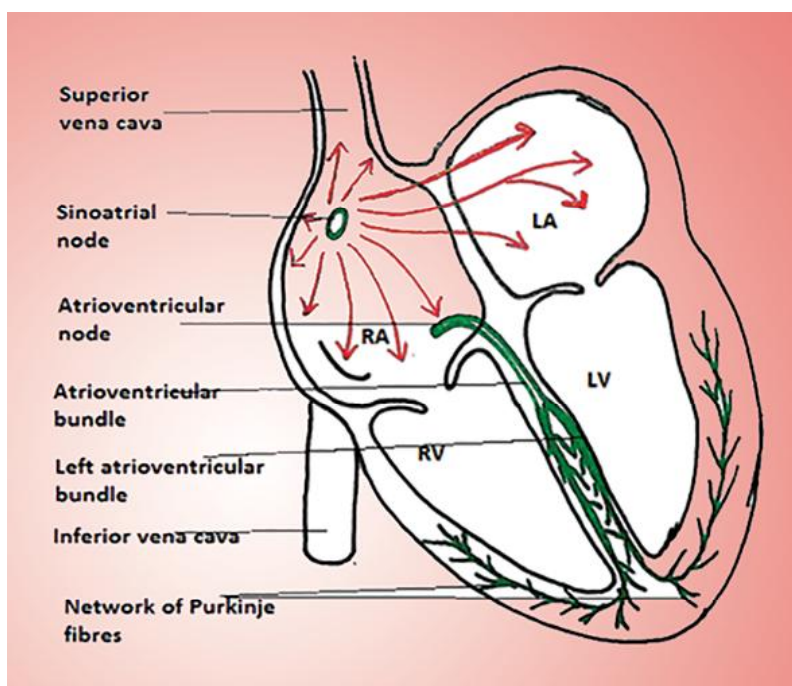
Two pulmonary arteries with oxygen poor blood leave the heart from the upper part of the right ventricle. Two pulmonary veins from each lung carry oxygen rich blood back to the left atrium. The aorta with oxygen rich blood leaves from the upper part of the left ventricles. The superior vena cava and inferior vena cava open into the right atrium and empty their contents into the right atrium. The heart is supplied with arterial blood by the right and left coronary arteries which branch from the aorta immediately after the aortic valve.

### **The conducting system of the heart**

Heart generates its own electrical impulses and beats independently of nervous or hormonal control. However it is supplied with both sympathetic and parasympathetic nerve fibers which increase and decrease respectively the intrinsic heart rate. In addition to that heart responds to a number of circulating hormones including adrenaline and thyroxine.

Small group of specialized neuromuscular cells in the myocardium initiate and conduct impulses. The conducting system of the heart consists of following specialized system.

- SA node (Sinoatrial node)
- AV node (Atrioventricular node)
- Atrioventricular bundle (bundle of His), bundle branches and Purkinje fibres



*Fig5.19: The conducting system of the human heart*

### **SA node / Sinoatrial node**

SA node is a small mass of specialized cells. It lies in the myocardium of the right atrium near the opening of the superior vena cava. The stimulus for contraction of the heart originates in the 'SA node'. The SA node initiates the heart beat and sets the rhythm of the heart beat so it is called the pace maker. But the heart rate can be varied by the stimulation from the autonomic nervous system, hormones such as adrenaline, thyroxine and temperature.

### **AV node**

AV node is also a small mass of specialized cells. It is situated between wall of the left and right atria. The AV node transmits the electrical signals from the atria into the ventricles.

### **Atrioventricular bundle (bundle of His), bundle branches and Purkinje fibres**

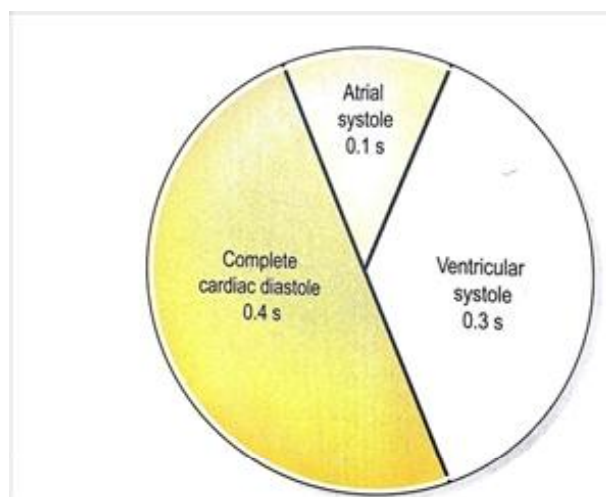
AV bundle is a mass of fibers. It originates from the AV node. The AV bundle crosses the fibrous rings that separate atria and ventricle at the upper end of the ventricular septum it divides into right and left bundle branches. Within the ventricular myocardium the branches break up into fine fibres. These fine fibers are Purkinje fibers. The AV bundle branches and the Purkinje fibers transmit electrical impulse from the AV node to the apex of the myocardium. As a result of this impulse, wave of ventricular contractions begin. Then the contraction sweeps upwards and outwards pumping blood simultaneously into the pulmonary artery and the aorta.

### The cardiac cycle

The cardiac cycle refers to the sequences of events that take place in a complete heart beat. During this process one complete cycle of pumping and filling of blood into the heart occurs. Complete cardiac cycle lasts for 0.8 second. It occurs as follows:

1. Atrial systole – Contraction of the atria
2. Ventricular systole - Contraction of the ventricles
3. Complete cardiac diastole – Relaxation of the atria and ventricles

At rest the healthy adult heart is likely to beat at a rate of 60- 80 beats per minute. During a single heart beat, the heart contracts (systole) and then relaxes (diastole). During a single contraction the amount of blood pumped by a ventricle is called the stroke volume.



Total period of 1 cycle = 0.8 second

*Fig 5.20: The stages of Cardiac cycle*

### Complete cardiac diastole

This lasts for 0.4 second. Both atria and ventricles are relaxed and blood return to the heart. The superior vena cava and the inferior vena cava transport oxygen poor blood into the right atrium. At the same time as the four pulmonary veins bring oxygen rich blood into the left atrium. The pressure of the atria is more than the pressure of the ventricles. Therefore atrioventricular valves are open and some blood flows passively through to the ventricles.

### Atrial systole

When blood flows into the atrium SA node is stimulated. Then SA node triggers a wave of contractions that spreads over the myocardium of both atria. Hence the remaining blood in the atria flows into the ventricles thereby emptying the atria. This lasts for 0.1 second.

### Ventricular systole

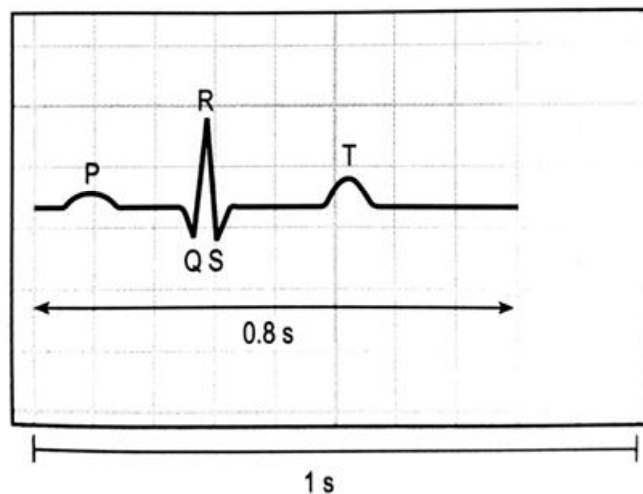
Through the atrial muscles the electrical impulses reaches the AV node. Then AV node triggers its own electrical impulses which quickly spread to the ventricular muscles via the AV bundle, the bundle branches, and Purkinje fibers. This results in a wave of contractions which sweep upwards from the apex of the heart across the wall of the ventricles. As a result both ventricles contract.

The pressure in the right ventricle is more than the pressure in the pulmonary artery and the pressure in the left ventricle is more than pressure in the aorta. Therefore pulmonary valve and aortic valves open and blood flows into pulmonary artery and aorta respectively.

The high pressure generated during ventricular contractions force the atrioventricular valves to close preventing backflow of blood into the atria. Ventricular systole lasts for 0.3 seconds. When ventricles relax, the pressure within them falls. The pulmonary and aortic valves close. Pressure within the pulmonary artery and aorta is more than pressure within the ventricles. The valves of the heart and great vessels open and close according to the pressure within the chambers of the heart. The sequence of opening and closing of valves ensure that blood flows only in one direction.

### Electrocardiogram (ECG)

Electrical activity in the heart can be detected on the surface of the skin by placing electrodes on the chest or limbs as the body tissues and fluids conduct electricity well. Such a recording is called an electrocardiogram (ECG). The ECG indicates the spread of the electrical signal generated by the SA node as it travels throughout the heart. The normal ECG tracing of a healthy individual shows five waves which by convention have been named P, Q, R, S and T.



*Fig 5.21: Electrocardiogram of one cardiac cycle*



**P wave** - It represents the impulse from the SA node as it sweeps over the atria (atrial depolarization).

**QRS wave complex** – Represents rapid spread of impulse from the AV node throughout the ventricles and electrical activity of the ventricular muscles.( ventricular depolarization)

**T wave** – Represents ventricular repolarization and relaxation of the ventricular muscles. Due to the larger QRS complex, atrial repolarization which occurs during ventricular contraction is not seen.

Information about the heart function of a person ( state of the myocardium and the cardiac conduction system) can be obtained by examining the pattern of waves and the time interval between cycles and parts of cycles.

### **Blood Pressure**

The force that the blood exerts on the walls of blood vessels as it travels is referred to as blood pressure. Blood pressure in the arteries of systemic circulation maintains the essential flow of blood into and out of the organs of the body.

It is very important to keep blood pressure within normal limits. High blood pressure could lead to damage blood vessels resulting in formation of clots or bleeding from damaged sites. If the blood pressure falls too low, there will be inadequate blood flow through tissue capillary beds. This will adversely affects the normal functioning of vital organs such as the brain, heart and kidneys.

Blood pressure varies according to the time of day, the posture, gender, age, activity, exercise and stress (Emotional states) of an individual. Blood pressure falls at rest and during sleep. Blood pressure increases during excitement, fear or anxiety.

### **Systolic and diastolic pressure**

#### **Systolic pressure**

Systolic pressure is the pressure produced within the arterial system when the left ventricle contracts and pushes blood into the aorta. At rest , systolic pressure in a normal healthy adult systolic pressure is about 120 mmHg.

#### **Diastolic pressure**

Diastolic blood pressure is the blood pressure within the arteries following ejection of blood at complete cardiac diastole(when the heart is at rest. In a normal healthy adult diastolic pressure is about 80 mmHg.

Arterial blood pressure is measured by a sphygmomanometer. It is expressed as

$$\frac{\text{Systolic pressure (mm Hg)}}{\text{Diastolic pressure (mm Hg)}}$$

120/80 mmHg

## **Hypertension and Hypotension**

### **Hypertension**

Sustained elevated blood pressure above normal limits is called hypertension.

Consequences of hypertension are kidney damage, adrenal gland disorders, heart attack (because of the increased heart rate and cardiac contraction), stroke (caused by cerebral haemorrhage), damaged blood vessels which can lead to death

### **Risk Factors for Hypertension**

- Obesity
- Diabetes mellitus
- Family history
- Smoking
- A sedentary life style
- High intake of salts
- High intake of alcohol
- Stress
- Deposition of low density lipoprotein (LDL) on artery walls.

### **Hypotension**

Sustained reduction of blood pressure below normal limits is called hypotension. Hypotension usually occurs as a complication of other condition such as shock, Dengue hemorrhage fever, standing up suddenly from sitting or lying position, over bleeding/ hemorrhage condition, fasting, low nutrition etc. Low blood pressure leads to inadequate blood supply to the brain. Depending on the cause unconsciousness may be brief (fainting) or prolonged possibly causing death.

### **Coronary circulation**

The heart is supplied with arterial blood by the right and left coronary arteries which branch from the aorta immediately distal to the aortic valve.

The coronary arteries travel the heart wall eventually forming a vast network of capillaries. Most of the venous blood is collected into a number of cardiac veins that joins to form the coronary sinus which opens into the right atrium. The remainder passes directly into the heart chambers through little venous channels.

### **Consequences of blockage of coronary arteries**

The inner lining of the arteries can be thickened and harden leading to the condition called atherosclerosis which occurs as a result of fatty deposits especially cholesterol particles. This can affect the normal blood supply to the organs and tissues.

One or more branches of coronary arteries can be blocked due to atherosclerosis which can be complicated by thrombosis (blood clot). Depending on the place (s) of the block in the coronary arteries and the degree of blockage related parts of the heart muscle will be deprived of oxygen and nutrients. Hence, narrowing of the arteries leads to chest pain (Angina). The complete occlusion due to the blockage of one or more coronary arteries leads to heart attacks (Myocardial infarction) which refers to the damage or death of cardiac muscle tissue due to lack of adequate oxygen and nutrients. Due to this, heart beat rhythm may be abnormal and the heart may cease to be an effective pump. The other vital organs such as brain may be deprived of inadequate supply of oxygen rich blood and heart attack may be fatal if not treated on time.

**Stroke** – Similarly blockage due to atherosclerosis or rupture of arteries supplying blood to the brain may cause the death of nervous tissue due to lack of oxygen and nutrients. This is referred to as stroke.

### **Respiratory pigments**

Respiratory pigments are organic compounds which can combine with oxygen where the partial pressure of oxygen is high and release oxygen where partial pressure of oxygen is low. Since oxygen is less soluble in watery medium including blood, transportation of oxygen from respiratory surface to the tissues/ organs is a problem for complex animals. To overcome this problem animals have evolved the respiratory pigments.

Different respiratory pigments can be seen in the animal kingdom:

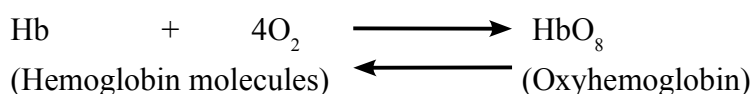
- Haemoglobin- present in blood of human, other vertebrate and annelids
- Haemocyanin- present in hemolymph of arthropods and molluscs.
- Chlorocruorin- present in the blood of many annelids
- Haemoerythrin- present in the blood of marine invertebrates (some annelids)
- Myoglobin- present in vertebrate muscles

All these respiratory pigments except myoglobin transport oxygen from respiratory surfaces to the tissues and organs and while transporting carbon dioxide from tissue/ organs to the respiratory surface for elimination. Myoglobin present in the muscle tissue has an oxygen storage function.

## Transport of respiratory gases in human blood

### Transport of oxygen

It is the hemoglobin molecule found in the erythrocytes which is responsible for the transport of oxygen around the body. Hemoglobin is composed of four subunits. Each subunit is composed of a globin protein and the haem group. Haem groups are responsible for the characteristic red colour of the blood. A ferrous (iron) atom is located within each haem group and each of these can combine reversibly with one molecule of oxygen. Therefore each hemoglobin molecule can carry up to four oxygen molecules.



Combination of oxygen with hemoglobin to form oxyhemoglobin

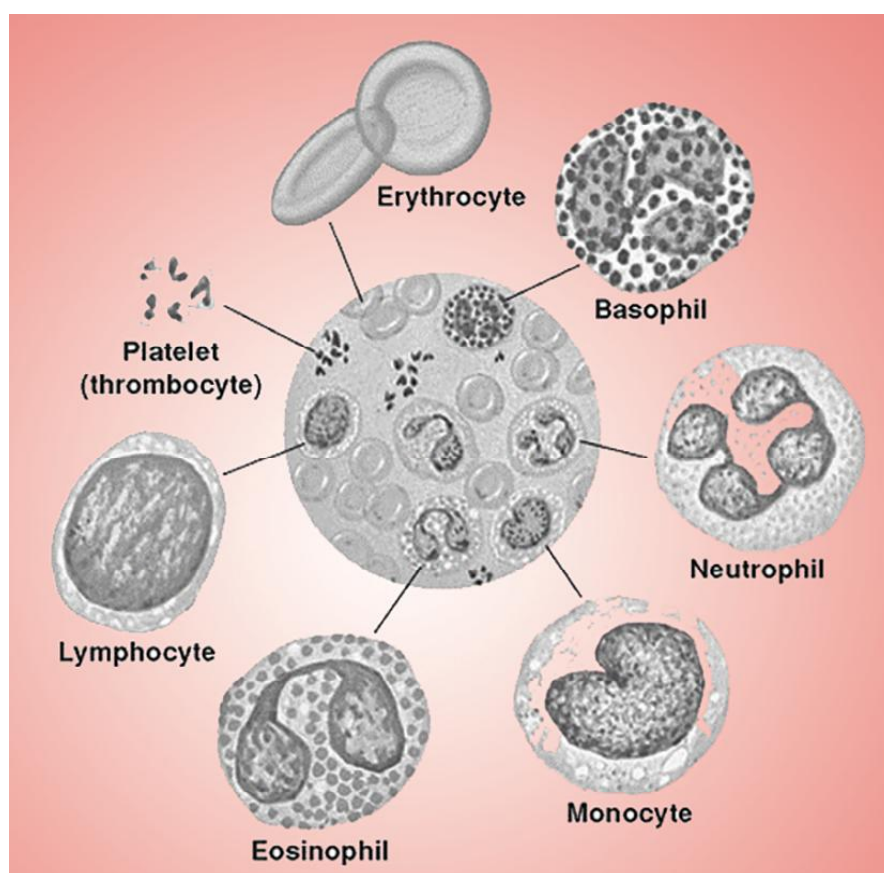
### Transport of Carbon dioxide

Carbon dioxide is carried by the blood in different ways.

- As  $\text{HCO}_3^-$  ions in the plasma (about 70%): When  $\text{CO}_2$  diffuses into the red blood cells the enzyme carbonic anhydrase catalyze the combination of  $\text{CO}_2$  with water to form bicarbonate ( $\text{HCO}_3^-$ ) and  $\text{H}^+$  ions. The  $\text{HCO}_3^-$  moves out of the erythrocytes into the plasma
- As carbaminohemoglobin (about 23%):  $\text{CO}_2$  combined with protein group of hemoglobin and form carbaminohemoglobin. Therefore  $\text{CO}_2$  does not compete with oxygen binding sites in hemoglobin.
- Dissolved in plasma (about 7%): as free gas.

### Composition and major functions of human blood

Blood which is a connective tissue is composed of cells and plasma. Cellular components of the blood are three types namely red blood cells, white blood cells and platelets. ((fig. 5.22) Red blood cells, leukocytes and platelets are developed from the bone marrow in the bones such as ribs, vertebrae, sternum and pelvis. Erythropoietin hormone (from kidneys) stimulates the generation of red blood cells.



*Fig 5.22: The composition of blood*

### **Red blood cells (erythrocytes)**

They are small biconcave disk-like cells. Mature erythrocytes lack nuclei. This character helps to carry more hemoglobin molecules within the cell. They also lack mitochondria thus they produce ATP via anaerobic respiration. If they produce ATP by aerobic respiration that will reduce the  $O_2$  transport efficiency. They have about 120 days of life span.

Generally a micro liter of blood contains 4- 6 million red blood cells. This figure can be varied depending on the gender and health status.

Main function of red blood cells is the transportation of  $O_2$  molecules. They also transport  $CO_2$  molecules.

### **White blood cells (Leukocytes)**

There are five types of leukocytes. They are Basophils, Lymphocytes, Eosinophils, Neutrophils and monocytes. Main functions of leukocytes are body defense, phagocytic engulfing and digesting microorganisms. Lymphocytes develop into T cells and B cells. These cells increase immune response against foreign substances.

**Platelets**

Platelets are derived from bone marrow cells. They also do not have nuclei and they play a major role in blood clotting.

**Blood plasma**

Blood plasma consists of inorganic ions in dissolved forms, plasma proteins such as albumin, antibodies and fibrinogen, nutrients, metabolic wastes, respiratory gases and hormones. pH of human blood is around 7.4. Protein concentration in plasma is higher than in interstitial fluid.

The dissolved ions in the plasma buffer and maintain the osmotic balance in the blood. Albumin in the plasma also buffers the blood and antibodies are involved in defense. Fibrinogen in the plasma aids in blood clotting. When the clotting factors are removed from the plasma it is called as serum.

**Major Functions of blood**

- Transport of oxygen to organs and removal of carbon dioxide from the organs and tissues
- Transport of soluble excretory materials to organs of excretion
- Transport of nutrients
- Transport of hormones from the glands where they are produced to target organs
- Defence against foreign invasions
- Aids in osmoregulation

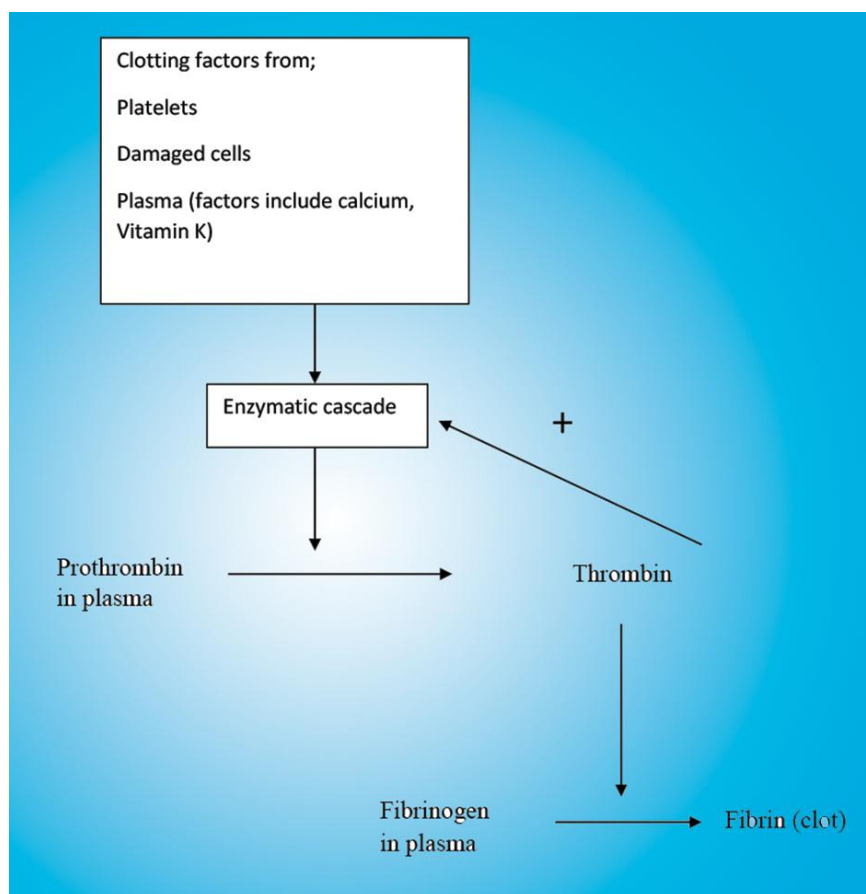
**Blood clotting**

When a tissue is damaged, blood flows from it and coagulates to form a blood clot. This prevents further blood loss and entry of pathogenic micro organisms which is of clear survival value. In general the blood in undamaged vessels does not clot.

A highly complex series of reactions takes place in order for coagulation to occur as well as prevent unwanted clotting. When the blood vessel is damaged the connective tissues of the vessel wall is exposed. Therefore platelets in the blood adhere to the collagen fibers in the connective tissue and release substance that makes close by platelets sticky. This platelet plug provides instant protection against blood loss.

Then platelets release clotting factors. They trigger the formation of thrombin. Then thrombin converts fibrinogen into fibrin. Next this fibrin aggregates into threads that form a network of the clot. The activated thrombin is also involved in formation of more thrombin which completes the formation of blood clot.

The cascade reaction during blood clotting is given below;



Clotting does not occur in undamaged blood vessels because the lining of the vessels is very smooth and does not promote platelet aggregation or cell rupture. Also some substances such as Heparin prevent clotting. Heparin prevent the conversion of prothrombin into thrombin and fibrinogen to fibrin and is widely used clinically as an anticoagulant.

### Grouping of blood

The surface of the red blood cells carries antigens called agglutinogen (antigen A and antigen B). In addition individuals have antibodies in plasma (anti-A and anti-B). According to ABO blood grouping system there are four blood groups namely A, B, AB and O. A person with a specific antigen in red cells does not possess the corresponding antibody in the plasma. e.g. Anyone with antigen A on the red blood cell membrane has no anti-A antibody in the plasma.

If red blood cells have antigen A and plasma has antibodies b (anti-B) that person's blood group is A

If red blood cells have antigen B and plasma with antibodies a (anti-A ) that person's blood group is B

If red blood cells have both antigen 'A' and 'B' and plasma has no anti-A or anti-B antibodies that person's blood group is 'AB'

If red blood cells have no antigen A or B but plasma has both antibodies (anti-A and anti-B) that person's blood group is 'O'

When a patient receives a blood transfusion it is vital that they receive blood that is compatible with their own. If it is incompatible a type of immune response occurs. This is because the donor's red cell membranes possess glycoprotein which act as antigens and react with antibodies (agglutinin) in the recipient's plasma. The result is that the donor's cells are agglutinated.

Therefore when transfusion occurs it is important to know blood group of donor and recipient. People with blood group AB make neither anti-A nor Anti-B antibodies. Transfusion of type A, B or AB blood into these individuals is likely to be safe since there are no antibodies to react with them. Person with AB blood group is known as a universal recipient.

Individual with blood group O has neither antigen A nor antigen B on their plasma membrane of red blood cells. but they do have antibodies (anti-A and anti-B) in their plasma. So these individuals having blood group O can donate blood to the persons with any blood group. A person with the blood group O is known as a universal donor. Therefore prior to transfusion cross-matching is still required to ensure that there is no reaction between donor and recipient blood.

### **The Rhesus system**

Some individuals have antigen called Rhesus factor on the plasma membrane of red blood cells. Individuals having this factor on the red blood cells are called Rh<sup>+</sup> and those who do not have this factor are called Rh<sup>-</sup>.

Rh<sup>+</sup> individuals do not have anti Rhesus antibodies in the plasma while individuals who are Rh<sup>-</sup> have anti-Rhesus antibodies in their plasma. However if Rh<sup>+</sup> blood enters a Rh<sup>-</sup> negative individual the recipient responds by manufacturing Rh antibodies in the blood plasma.

When a Rh<sup>-</sup> mother bears a Rhesus positive (Rh<sup>+</sup>) child during delivery few Rh<sup>+</sup> red blood cells of the fetus may enter the mother's circulation and cause the mother to produce Rh antibodies in her plasma. If the mother is pregnant for the second time with a Rhesus positive fetus, the Rh antibodies developed in her plasma in response to the first child's red blood cells can pass across the placenta to the fetus and destroy fetal red cells. Normally Rh antibodies are not formed in large enough quantities in the mother's plasma to affect the first born child. However subsequent Rh<sup>+</sup> children can suffer destruction of their red blood cells.



## Gas exchange in animals

### Need of respiratory structures in animals and evolution of complexity of respiratory structures in different animal groups

Respiratory gas exchange (uptake of oxygen into the body and release of carbon dioxide into the external environment) occurs by diffusion. In simple animals e.g. cnidarians and flat worms every cell in the body is close enough to the external environment so that gas exchange can occur directly between all cells and the environment. Diffusion through body surface is adequate as these animals have a simple body form and low energy requirement.

In large animals, body complexity and energy requirement is high and the bulk of the cells in the body lack immediate access to the external environment. Hence, gas exchange through the body surface is not adequate to full fill their energy requirements. As a result, specialized surfaces referred to as respiratory surfaces have evolved where gaseous exchange occurs.

With the increase of the body size and complexity the surface area to volume ratio (A/V) of animals decreases. However, a large surface area is required for efficient gas exchange and thus diverse respiratory structures with large surface area with folding and branching has evolved for efficient gas exchange. Examples for such respiratory structure are Gills, Trachea, and lungs. External projections of the body such as gills were evolved in aquatic animals for efficient extraction of dissolved oxygen from water. On the other hand, surface invaginations like trachea and lungs were evolved in terrestrial animals for efficient extraction of oxygen from the atmosphere.

### Characteristics of respiratory surfaces

An effective respiratory surface must have the following properties.

- It must be permeable, and wet so that gases can pass through by dissolving.
- It must be thin because diffusion is only efficient over short distances.
- It should possess a large surface area to allow a sufficient volume of gases to be exchanged according to the organism's need.
- It should possess a good blood supply (maintain a steep diffusion gradient)

### Respiratory structures in animals

- Body surface: Cnidarians, Flatworms, Earthworms
- Gills

- External Gills: marine annelids
- Internal Gills: Fish, shrimps, prawns
- Tracheal systems: Insects
- Lungs: Mammals (Human), Reptiles, Birds.
- Skin: Amphibians
- Book lungs: Spiders, Scorpions

## Human Respiratory System

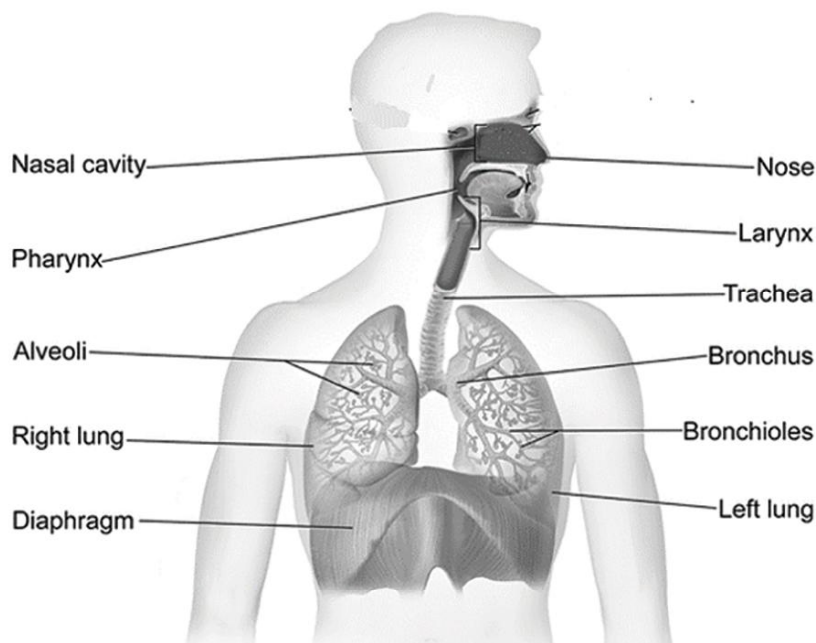
### Gross structure and function of the human respiratory system

Human respiratory system consists of the following major parts: nostrils, nasal cavity, pharynx, larynx, a series of branching ducts starting from the trachea, two bronchi one leading to each lung and smaller bronchioles, which finally end in air sacs called alveoli. The bronchioles and the alveoli are contained within the paired, cone-shaped lungs located in the thoracic cavity. The two lungs differ slightly in shape and size. The left lung is slightly smaller than the right because the apex of the heart is slightly to the left of the median plane and it has 2 lobes while the right lung has 3 lobes. Each lung is surrounded by two membranes. The inner membrane, called the visceral pleura adheres to the outer surface of the lungs while the outer membrane called the parietal pleura adheres to the wall of the thoracic cavity. Between these two membranes there is a thin, fluid filled space.

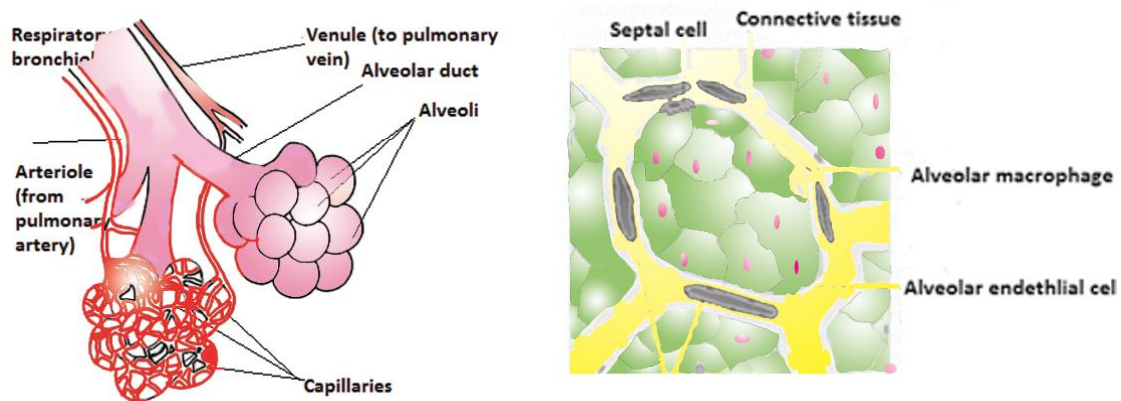
During respiration, air enters the respiratory system through the nostrils. In the nasal cavity air is filtered by hairs and is warmed and humidified as it travels through spaces in the nasal cavity. The nasal cavity leads to the pharynx which is a common passage for both air and food. That means air passage and food passage cross each other. During swallowing of food the larynx moves upwards which allows the epiglottis to close the opening of the larynx called the glottis. This allows food to go down the esophagus to the stomach. The rest of the time the glottis is open so that air can move from the pharynx through the larynx to the trachea. In the larynx are vocal cords which are made up of largely elastic fibers. These vocal cords help produce sound when expired air rushes across the stretched or tensed vocal cords, causing them to vibrate. Both the walls of the larynx and trachea are strengthened by cartilage that help these airways to keep open. The air passes from the trachea into the two bronchi that lead into each lung. Within the lungs the air passes through smaller and smaller branches of the bronchi called bronchioles.

The epithelium found in the major branches of this respiratory tract has cilia and a thin film of mucus. The mucus helps trap the dust and other particulate contaminants in the inhaled air. Then the beating of cilia moves this mucus upwards towards the pharynx where it is swallowed into the esophagus. This process is referred to as the “mucus escalator”. It helps clean the respiratory system.

At the tips of tiniest bronchioles are large number of small air sacs clustered together. The air passes into these air sacs called alveoli where gas exchange occurs. The walls of the alveoli are made up of a single layer of flattened epithelial cells that lack cilia. This inner lining of the alveoli is coated by a thin film of fluid. The lungs contain millions of alveoli. This allows a large surface area for gas exchange. Each alveolus is also surrounded by a network of capillaries. Oxygen in the air that enters the alveoli dissolves in the moist film and rapidly diffuse across the thin epithelium into the capillaries. Meanwhile a net diffusion of carbon dioxide occurs from the capillaries into the alveoli. Since there are no cilia in the alveoli, there are white blood cells in the alveoli to engulf foreign particles. Alveoli are also coated with a surfactant that reduces the surface tension thereby preventing the collapse of alveoli due to high surface tension.



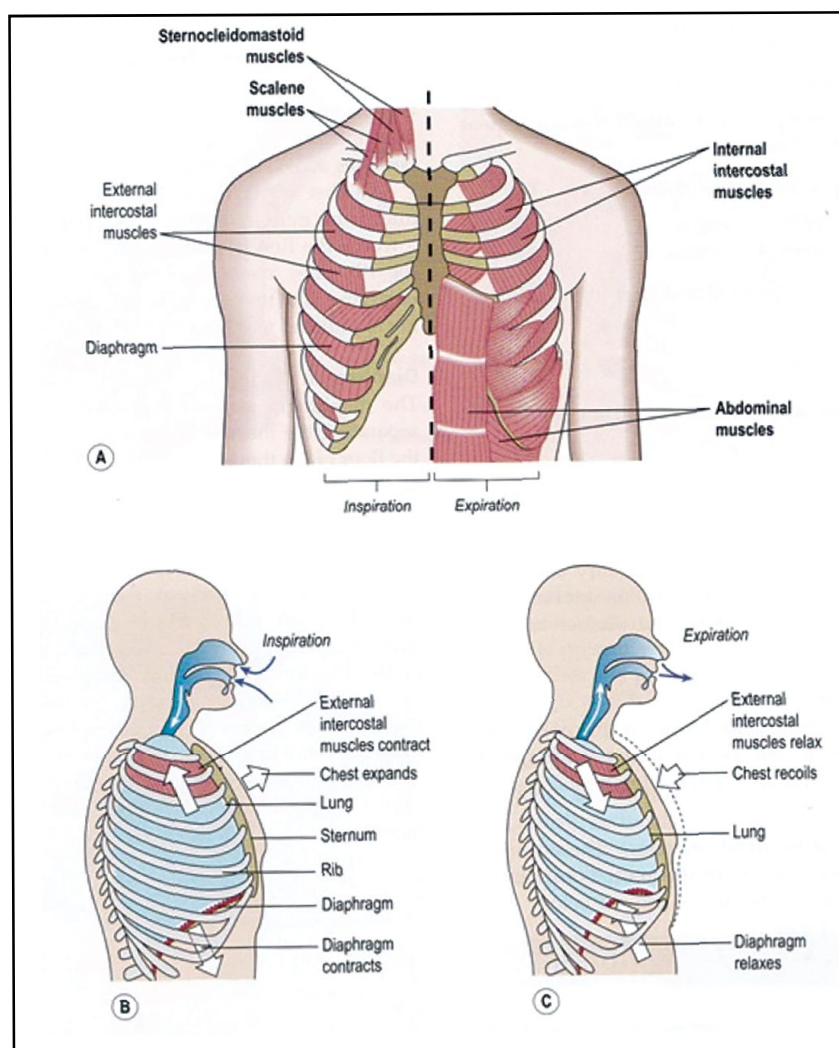
*Fig 5.23: Gross structure of human respiratory system*



*Fig 5.24: The alveoli and their capillary network*

**Mechanism of ventilation of the lungs**

- Ventilation of the lungs is necessary to maintain high oxygen and low carbon dioxide concentrations in the alveoli or the gas exchange surface.
- Ventilation is accomplished by breathing, which is the alternating movement of air into (inhalation) and out of (exhalation) the lungs.
- Humans employ what is referred to as negative pressure breathing where air is pulled rather than pushed into lungs.
- Inhalation is an active process. Contraction of rib muscles or intercostal muscles and the diaphragm which is a sheet of skeletal muscle that forms the bottom of the thoracic cavity leads to the expansion of the thoracic cavity.
- The visceral and parietal pleurae surrounding the lung stick together due to the surface tension of the fluid between these two membranes. This allows the two membranes to slide smoothly past each other. Hence, as the volume of the thoracic cavity increases, the lung volume increases as well.
- As a result, the pressure within the lungs decrease relative to the outside air.
- This creates a pressure gradient between the atmosphere and the lungs.
- Thus, air flows from a high pressure gradient in the atmosphere to a lower pressure gradient in the lungs.
- During exhalations which is usually a passive process, the rib muscles and the diaphragm relax. This cause the volume of the thoracic cavity to reduce.
- As a result, the pressure inside the lungs increase in relation to the air outside. This pressure forces air to move out of the lungs through the respiratory tubes into the atmosphere.
- When a man is at rest contraction of rib muscles and contraction of diaphragm are enough for breathing.
- However, depending on the activity level, additional muscles may be used to aid breathing such as muscles of the neck, back and chest. These muscles further help to increase the volume of the thoracic cavity by raising the rib cage. e.g. during exercise



**Fig 5.25: (A) Muscles involved in respiration; (B) and (C) Changes in chest volume during inspiration and expiration**

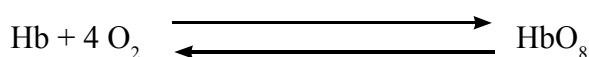
- The lungs serve as an efficient respiratory surface because:
- Alveoli create a large surface area for gas exchange.
- Alveoli and capillary walls are both lined by simple squamous epithelia which reduce the distance the gasses need to travel by diffusion.
- The alveoli surface is moist to dissolve respiratory gasses for diffusion.
- Alveoli are highly vascularized which enables the maintenance of a steep diffusion gradient of respiratory gasses

Gas exchange at the alveoli and in the tissues is a continuous process. It requires transport of  $O_2$  from the lungs to the blood and movement of  $CO_2$  from the blood (referred to as external respiration) and movement of  $O_2$  from blood to the tissues and  $CO_2$  from tissues to the blood (referred to as internal respiration).

Diffusion of  $O_2$  and  $CO_2$  requires partial pressure gradients between the alveolar air in the lungs and blood (during external respiration) and blood and tissues (during internal respiration).

During inhalation, fresh air mixes with the stale air in the lungs. This mixture in the lungs has a higher partial pressure of oxygen ( $PO_2$ ) and a lower partial pressure of carbon dioxide ( $PCO_2$ ) than the blood in the alveolar capillaries. There is thus a concentration gradient favoring the diffusion of these two gases in opposite directions. Net diffusion of  $O_2$  takes place from the air in the alveoli to the blood and net diffusion of  $CO_2$  takes place from the blood into the alveoli.

When  $O_2$  molecules diffuse into blood capillaries they bind to haemoglobin in the red blood cells. Four molecules of  $O_2$  bind reversibly with one molecule of haemoglobin and form oxyhaemoglobin.



When blood leaves the alveolar capillaries the oxygen and carbon dioxide partial pressures are in equilibrium with those of alveoli air. Once this blood returns to the heart, it is pumped through the systemic circuit.

Blood reaching the tissues in the systemic capillaries have a higher  $PO_2$  and a lower  $PCO_2$  than in the tissues. These partial pressure gradients result in the net diffusion of  $O_2$  from the blood stream into the tissue and  $CO_2$  diffusion from the cells into the blood stream across the extracellular fluid/interstitial fluid. This is called unloading of  $O_2$  and loading of  $CO_2$ . Then the blood returns to heart and pumped to lungs again.

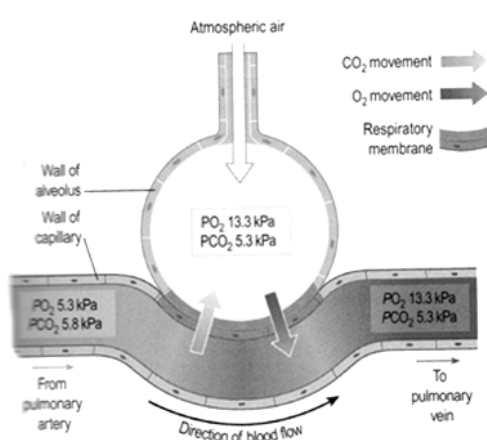


Fig 5.26: External respiration

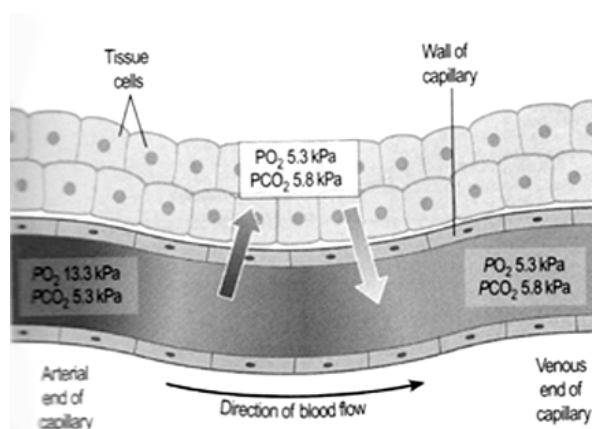
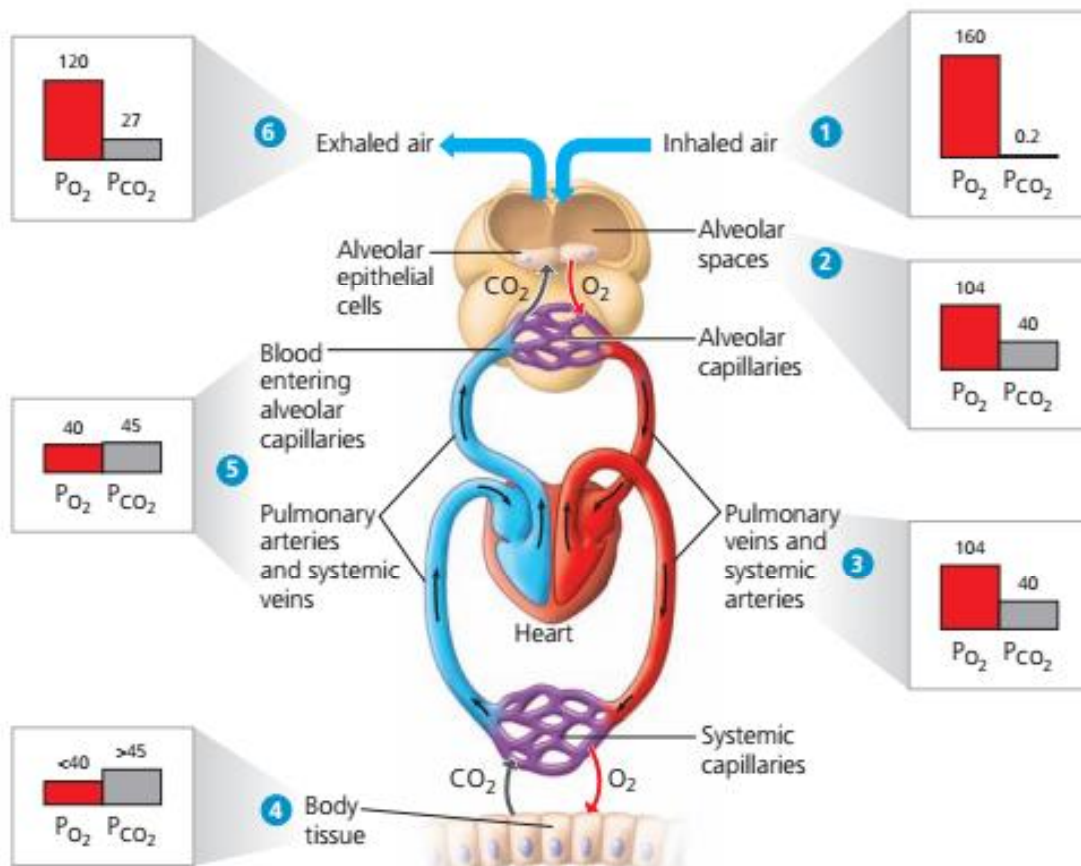


Fig 5.27: Internal respiration



*Fig 5.28: Loading and unloading of respiratory gases*

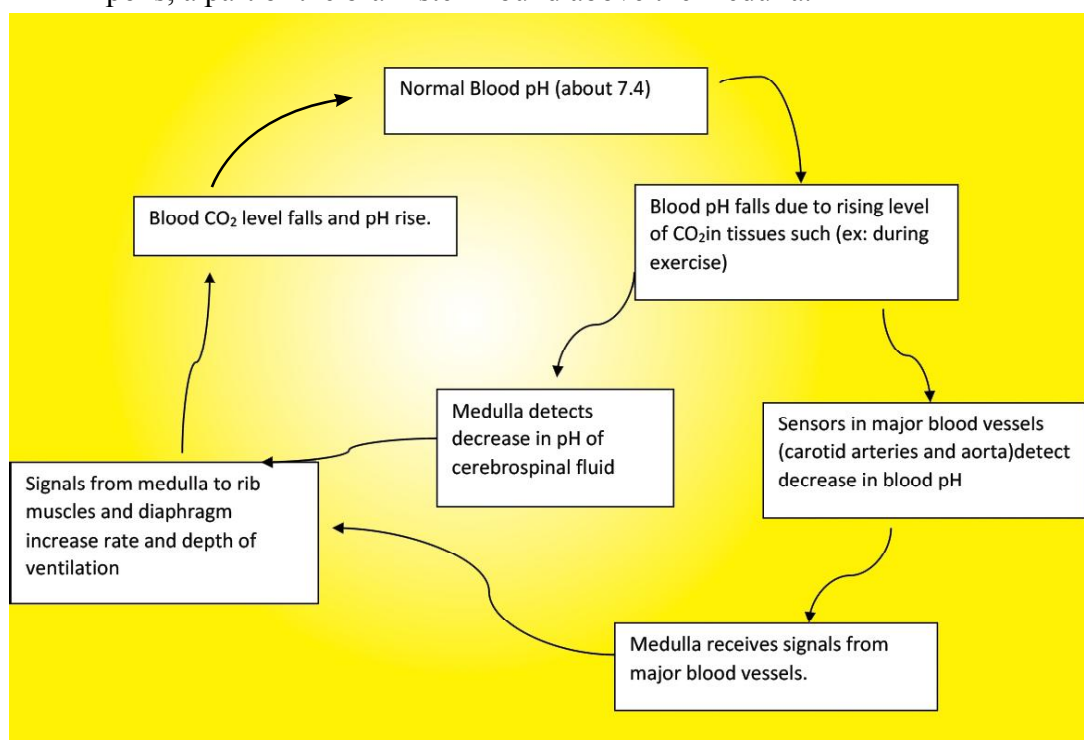
### Homeostatic control of Breathing

- Typically breathing is regulated by involuntary mechanisms. These involuntary mechanisms help coordinate gas exchange with blood circulation and metabolic demands
- Medulla oblongata is the main breathing regulating center found at the base brain. There are a pair of breathing control centers found in medulla and they are responsible for regulating the breathing rhythm.
- A negative-feedback mechanism is involved in regulating this process. Sensors which detect stretching of the lung tissues are found in the lungs. During inhalation, these sensors send nerve impulses to the neurons that act as control circuits in the medulla and further inhalation is inhibited and this prevents the lungs from over expanding.
- To regulate breathing, the medulla depends on pH changes in tissue fluids. The pH of tissue fluid is an indicator of blood carbon dioxide concentration. For

example, when metabolic activities increase, the concentration of  $\text{CO}_2$  in the blood increases. Because  $\text{CO}_2$  diffuses into the cerebrospinal fluid, this results in an increase of  $\text{CO}_2$  concentration in the cerebrospinal fluid as well. There  $\text{CO}_2$  reacts with water and form carbonic acid ( $\text{H}_2\text{CO}_3$ ).  $\text{H}_2\text{CO}_3$  dissociate into  $\text{HCO}_3^-$  and  $\text{H}^+$



- Hence, a high  $\text{CO}_2$  concentration results in an increase in  $\text{H}^+$  concentration, thereby a lower pH.
- This pH change is detected by the sensors in the medulla and in major blood vessels called arteries and aorta.
- Sensors in the medulla and major blood vessels detect this decrease in pH. In response, the control circuits in medulla increase the depth and rate of breathing until the excess  $\text{CO}_2$  is removed in exhaled air and the pH of blood comes to its normal value which is 7.4
- The  $\text{O}_2$  level has little influences on the breathing control centers. But, when  $\text{O}_2$  concentration becomes very low,  $\text{O}_2$  sensors found in the aorta and the carotid arteries send impulses to the medulla to increase the breathing rate.
- The regulation of breathing is also modulated by additional neural circuits in the pons, a part of the brain stem found above the medulla.



**Fig5.29: Homeostatic control of breathing**



## **Disorders of the respiratory system**

### **The effect of smoking on the smooth functioning of the respiratory system**

- Cigarette smoke harms nearly every organ in the body including the organs of the respiratory system and increase the risk of illness, disability and death. Smokers inhale large number of chemicals which mainly come from burning tobacco. Some of these inhaled compounds are chemically active and can trigger damaging changes in the body.
- Nicotine is among the compounds inhaled in tobacco smoke which is the addictive drug in the smoke. It temporarily increases the rate of heart beat and constriction of peripheral blood vessels causing a temporary increase in blood pressure.
- Cigarette smoke stimulates the secretion of mucus by the goblet cells and inhibits the action of cilia in the respiratory tract causing accumulation of mucus in bronchioles and blocking them, leading to bronchial inflammation or bronchitis. As a result, breathing may become difficult.
- Some chemicals such as hydrogen cyanide in cigarette smoke stops the cilia from working properly. Due to loss of action of cilia, dust and other particulate matter get collected in the lung, resulting in an increase in phagocytic cells in the lung tissue. Due to release of large amounts of lytic enzymes by these cells, the alveolar tissue is destroyed thus reducing the effective area available for gas exchange.
- Carbon monoxide (CO) present in tobacco smoke is absorbed into the blood and is able to bind to hemoglobin better than oxygen and combines irreversibly with hemoglobin. Thus it decreases the amount of oxyhaemoglobin produced. Therefore, oxygen transport through blood is decreased.
- Tobacco smoke also contains a large number of cancer-causing substances (carcinogens). Nearly 90% of lung cancers are due to smoking. Long term exposure to such chemicals in cigarette smoke results in the proliferation of cells in the bronchial epithelium, forming a mass of abnormal cells. A cancer may develop among these cells. If these cells break free, the cancer may spread to other parts of the lungs and or to other organs.
- Passive or second hand smoking will also result in the above mentioned ill effects.

### **Silicosis**

This may be caused by long-term exposure to dust containing silica compounds. High risk industries are,

- Quarrying granite, slate, sandstone

- Mining hard coal, gold, tin, copper
- Stone masonry and sand blasting
- Glass and pottery work

When silica particles are inhaled they accumulate in the alveoli. These particles are ingested by macrophages, some of which remain in the alveoli and come out in to the connective tissue around bronchioles and blood vessels close to the pleura. Progressive fibrosis is stimulated which eventually obliterates the blood vessels and respiratory bronchioles. Gradual destruction of lung tissue eventually leads to pulmonary hypertension and heart failure.

### **Asbestos related diseases - Asbestosis**

Those who are involved in making or using products containing asbestos are at risk. This occurs when asbestos fibers are inhaled with dust. In spite of their large size the particles penetrate the level of respiratory bronchioles and alveoli. Macrophages accumulate in the alveoli and the shorter asbestos fibers are ingested. The larger fibers are surrounded by macrophages, protein materials and iron deposits. The macrophages that have engulfed fibers move out of the alveoli and accumulate around respiratory bronchioles and blood vessels, stimulating the formation of fibrous tissue. These cause progressive destruction of lung tissue and pulmonary hypertension.

### **Lung cancer**

Nearly 90% of lung cancer is due to smoking. When one smokes, the nasal hairs, mucus and cilia in the respiratory tract that otherwise is sufficient to protect the lung from chemical and biological irritants, are overwhelmed and eventually stop functioning. As a result, irritants, free radicals, carcinogens and pathogens accumulate in the lungs. Eventually these cause lung cancer.

### **Tuberculosis (TB)**

Tuberculosis is an infectious disease caused by the bacterium *Mycobacterium tuberculosis*. The bacterium spreads when an infected person coughs and the bacterium enters the body of an uninfected person through inhaled air. The most common form is Pulmonary TB which affects the lungs. Other organs may also be affected. Transmission of pulmonary TB is by inhaling the bacterium into the lungs. This bacterium can survive in the air and in the house dust for long periods. Malnutrition and other infectious can reduce resistance to the disease.

#### **Symptoms**

Loss of appetite, loss of weight, excessive sweating, fever, a racking cough and spitting up blood.

## Asthma

Asthma is characterized by wheezing and chest tightness causing breathing difficulty. This is caused by the sudden contractions of smooth muscles in the walls of the bronchioles which causes the bronchioles to narrow or even close. During this time breathing causes whistling or wheezing sound. The cause of asthma is an over reaction of an immune response to stimuli like pollen, dust, mites, spores, particular food, cold air, exercise, smoking gases. Anti-inflammatory drugs help control.

## Respiratory cycle and lung volumes and capacities

Inhalation and exhalation during a single breath is referred to as a respiratory cycle. The amount of air that flows in and out of the lungs depends on the conditions of inspiration and expiration. Thus, four respiratory volumes are described.

- **Tidal volume (TV):** This is the volume of air inhaled and exhaled with each breath during normal breathing. On average it is about 500 ml in a resting adult human.
- **Inspiratory reserve volume (IRV):** This is the extra volume of air that can be forcibly inhaled beyond the tidal volume.
- **Expiratory reserve volume (ERV):** The extra volume of air which can be expelled from the lungs after a tidal expiration.
- **Residual volume (RV):** The volume of air that remains in the lungs even after forceful expiration. This is on average is about 1,200 ml.

Specific combinations of respiratory volumes are called respiratory capacities. Thus, respiratory capacities always consist of two or more lung volumes. The respiratory capacities are important to determine the respiratory status of a person.

- **Inspiratory capacity (IC):** The total volume of air that can be inspired after a tidal expiration.

Thus,  $IC = TV + IRV$

- **Functional residual capacity (FRC):** The volume of air remaining in the lungs at the end of a tidal expiration.

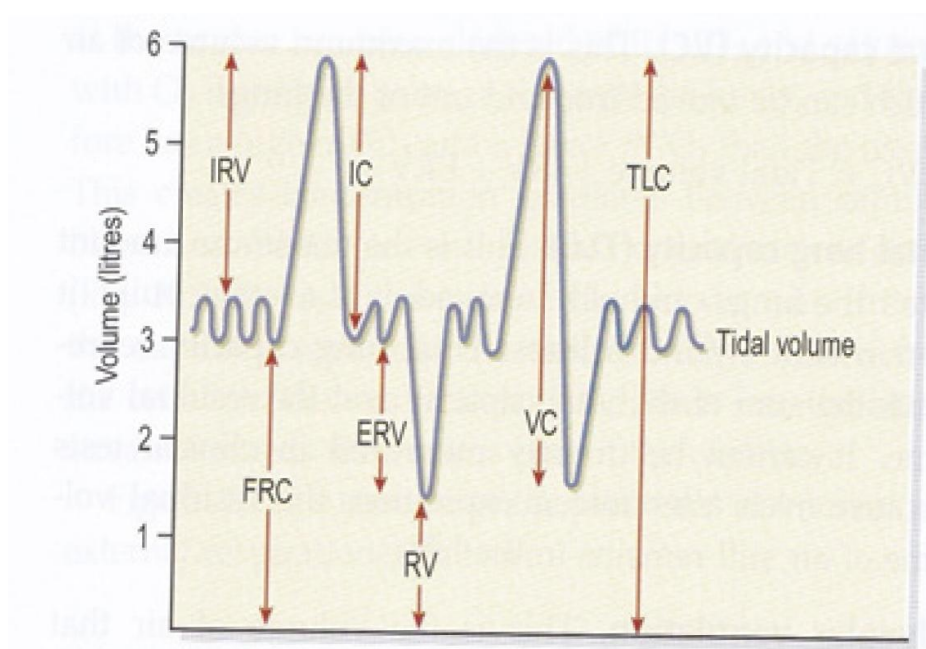
Thus,  $FRC = RV + ERV$

- The functional residual capacity is important for continuous exchange of gas in the alveoli and to prevent the collapse of the alveoli during expiration.
- **Vital capacity (VC):** The maximum volume of air which can be inhaled and exhaled. It is normally around 3100 mL in women and 4800 mL in men.

$VC = TV + IRV + ERV$

- **Total lung capacity (TLC):** The maximum volume of air the lungs can hold or the sum of all lung volumes. This is normally around 6000 mL.

In addition, some of the inspired air fills the system of branching conducting tubes (trachea, bronchi and bronchioles) and never contributes to the gas exchange in the alveoli. This volume is referred to as the anatomical dead space and it is typically about 150 mL.



**Fig 5.30: Lung volumes and capacities**

- IRV: Inspiratory reserve volume
- IC: Inspiratory capacity
- FRC: Functional residual capacity
- ERV: Expiratory reserve volume
- RV: residual volume
- VC: Vital capacity
- TLC: Total lung capacity

## Immunity

The state of being resistance to injury, invading pathogens and foreign substances through defensive mechanisms in the body is known as immunity. Pathogens which are the agents that can cause infectious diseases include some bacteria, virus, and fungi. The substances that can be recognized as foreign to the body include chemical components of pollen grains, incompatible blood cells and transplanted tissues. Defenses in the animal body against these foreign invasions make up the immune system. Immune system of animals should be able to distinguish own body cells (self) from foreign cells/particles within the body (non-self) for initiating defensive immune responses for destruction of the foreign agents such as pathogens. Special cell types in the body fluid and tissues of most animals can interact with these foreign invasions and destroy them. Immune cells produce receptor molecules that bind specifically to molecules from foreign cells and agents and activate defense responses.

Immune responses in animals can be divided into two types:

- Innate immunity
- Acquired immunity (Adaptive immunity)

### **Innate immunity**

Innate immunity is the ability to resist damage or diseases in the body through inherent body defenses which offer rapid responses against a broad range of pathogens and foreign substances. In innate immunity, recognition and defense responses will depend on characters common to groups of pathogens. Innate immunity lacks specific responses to specific invaders and its protective mechanisms functions the same way regardless of the type of the invader. Hence innate immunity is also known as non-specific defense. Innate immune responses include defense mechanisms that provide immediate but general protection against foreign invasion. Innate immunity is found in both invertebrates and vertebrates. Innate defense mechanisms can be broadly divided into two types: External barriers (External defenses/ barrier defense) and Internal nonspecific defenses (Internal defenses).

### **External defenses/ barrier defense in innate immunity**

External barriers discourage pathogens and foreign substances from penetrating the body. So they are considered as the first line of defense. For innate immunity in the human body, external defenses/barriers are found in the skin, mucus membranes and secretions of various organs. They act as physical and chemical barriers.

- Human **skin** with its many layers of closely packed, keratinized cell layers in the epidermis provides a significant physical barrier to entrance of microbes. In addition periodic shedding of epidermal cells helps remove microbes from the skin surface.
- The **mucous membranes** which line the body cavities provide a physical barrier to entrance of many microbes (e.g. the linings of the respiratory tract, digestive tract, urinary tract and reproductive tract). The mucous membranes produce mucus which traps microbes and other particles. In the respiratory tract, ciliated epithelial cells sweep mucus and any entrapped material upward. Coughing and sneezing speed up the mucus movement and its entrapped pathogens out of the body preventing their entry to the lungs.
- **Secretions** by various organs (e.g. tears, saliva, mucus) help as physical and chemical barriers to protect epithelial surface of the skin and mucous membranes. Tears in the eyes provide protection against irritants and microbes. Tears in the eyes provide continuous washing action that helps to dilute microbes and prevent settling on the surface of eyes. Saliva washes microbes from the mouth surface and the flow of saliva reduces the colonization of microbes in the mouth. Mucus secretions which bathe various exposed epithelia provide a continual washing action to dilute and inhibit colonization microbes such as bacteria and fungi. Lysozyme (an enzyme) present in tears, saliva, perspiration and mucous secretions can destroy cell walls of some bacteria. Gastric juice which provides an acidic environment in the stomach can destroy many bacteria and bacterial toxins ingested with food. Secretions of the sweat and sebaceous glands of the skin give acidity of the skin which helps to prevent growth of bacteria.

### **Internal defenses in Innate immunity**

When the pathogens penetrate the external defensive barriers in the skin and mucus membranes in the human body, they encounter a second line of innate immunity responses called internal defenses. Within the body, detection of non-self is accomplished by molecular recognition in which receptor molecules on specific cells in the immune system will bind specifically to molecules of foreign agents such as pathogens.

In innate immunity, internal defenses consist of Phagocytic cells, Natural killer cells, Antimicrobial proteins and Inflammatory responses.

- **Phagocytic cells:** These are specialized cells that can ingest microbes, foreign particles and cell debris for intra cellular digestion and destruction. Phagocytes use the receptor molecules to detect components of foreign agents and particles. Neutrophils and Macrophages are the two main types of phagocytic cells in man. While circulating in the blood, neutrophils are attracted first to the infected site

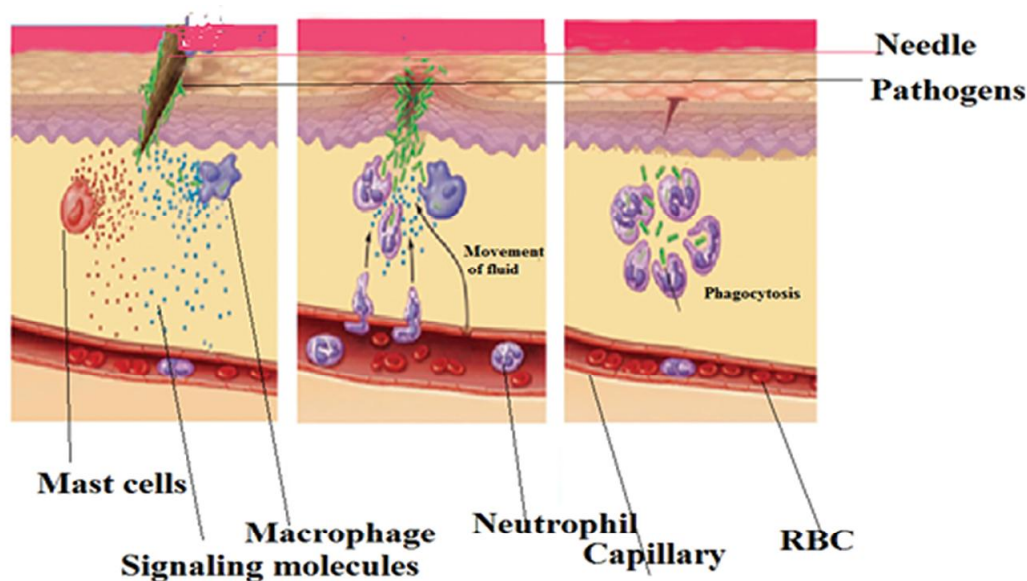
by signals from affected tissues. Then neutrophils can ingest and destroy infected pathogens. Macrophages are larger and more potent phagocytic cells.

- **Natural killer cells:** These are a type of lymphocytes present in the blood and some tissue/organs such as spleen and lymph nodes which function in nonspecific defense. They can detect the cells with abnormal surface molecules (e.g. virus-infected body cells and some cancerous cells) and kill them. Natural killer cells do not engulf these abnormal cells but upon binding they can release chemicals to kill the virus-infected cells and cancerous cells which could inhibit further spread of the virus or cancer.
- **Antimicrobial proteins:** They are proteins present in the blood and interstitial fluids which function in innate defense by attacking microbes directly or impeding their reproduction. Interferons and Complement proteins are two such antimicrobial proteins that discourage microbial growth. **Interferons** are proteins secreted by virus-infected body cells that protect uninfected host cells from viral infections by interfering with the viral replication. Once released by virus-infected cells, interferons diffuse to uninfected neighboring cells where they are stimulated to produce “anti-viral proteins” which inhibit viral replication. Some interferons activate macrophages which enhance the phagocytic activity. Complement proteins are a group of normally inactive proteins in the blood plasma and plasma membranes. When they are activated by different substances present on the surfaces of microbes, a cascade of biochemical reaction occurs which lead to lysis of invaded cells. They also promote phagocytosis and inflammatory response.
- **Inflammatory response:** This is an innate immune defense response in the body to tissue damage triggered by microbial infections or injury of the tissues. This involves the release of substances that promote increased permeability and dilation of blood vessels, enhance migration of phagocytes, destruction of invading pathogens and aid in tissue repair (Figure 5.31). Inflammation attempts to destroy the microbes at the site of the injury preventing the spread to other tissues and promote tissue repair.

Inflammatory response is brought about by various signaling molecules upon infection or injury. Histamine is one of the important inflammatory signaling molecules released mainly by mast cells in the connective tissues at the site of damage. Histamine causes increased permeability and dilation of nearby blood vessels (blood capillaries). Increased permeability of the blood vessels enhance the infiltration of white blood cells, antimicrobial proteins and clotting elements to enter the injured area from the blood that aid in destruction of invading pathogens and tissue repair. Dilation of blood vessels allows more blood to flow through the damage area which helps to remove dead cells. Activated phagocytes (macrophages and neutrophils) moved from the

blood to the damaged tissue area can also discharge signaling molecules (cytokines) which also promote blood flow to the injured or infected site. During inflammation, activated complement proteins can cause further histamine release which attracts more phagocyte cells to enter injured tissue and carry out additional phagocytosis. This process can digest the microbes and cell debris at the site of injury.

Signs and symptoms of inflammation are redness, heat, swelling and pain. Dilation of blood vessels causes redness and heat production due to high metabolism in the area. Increased permeability of blood vessels triggers localized swelling due to leaking of tissue fluid into neighboring tissues. Pain results from injury to neurons and microbial toxins. As a result of most inflammatory responses, pus may be accumulated. It is a fluid rich in dead phagocytes, dead pathogens and cell debris from the damaged tissue. Minor injury or infection causes a localized inflammatory response. If the injury or infection is severe it may lead to a systemic response (throughout the body) leading to fever. Elevated body temperature within limits may enhance the phagocytosis and accelerate tissue repair by speeding up the chemical reactions.



*Fig 5.31: Major events in inflammatory response*

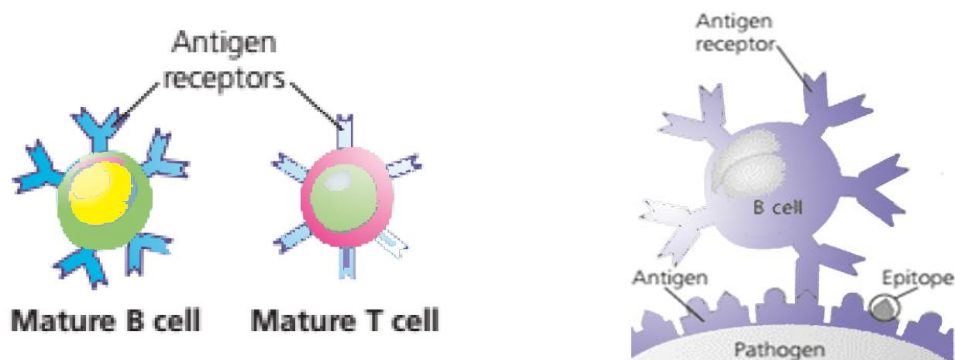
### Acquired Immunity (Adaptive Immunity)

Acquired immunity is the ability of the body to defend itself against invading foreign agents (e.g. pathogens) through specific defense responses mediated by diverse **T lymphocytes and B lymphocytes**. Acquired immunity shows (i) specificity for particular foreign molecules (ii) recognition of animals own molecules (self-molecules) from non-self-molecules and (iii) memory for most previously encountered pathogens such that the subsequent encounter causes a stronger and more rapid response (immunological memory). In the animal kingdom, acquired immunity is found only in the vertebrates.



The cells that have developed the ability to carry out acquired immune responses if they are activated against foreign agents are called **T lymphocytes** and **B lymphocytes**. In man, both types of lymphocytes are originated from stem cells in the bone marrow. Some of the lymphocytes that migrate to thymus for maturation are called T lymphocytes (T cells). The lymphocytes that remain in the bone marrow for completion of development are called **B lymphocytes** (B cells). Before leaving these lymphocytes to the secondary lymphatic tissues, their plasma membranes acquire diverse specific protein receptors (antigen receptors) which have the ability to recognize specific foreign invasions (There can be over 100,000 antigen receptors on the surface of a single B lymphocyte or T lymphocyte)

An **antigen** is a substance that has the ability to stimulate an immune response through T lymphocytes and B lymphocytes and to react with the specific cells or antibodies that resulted from the stimulated immune response. Viral proteins, bacterial toxins and chemical components of bacterial structures such as flagella and cell walls can be antigenic. Structural components of incompatible blood cells, transplanted tissues can also be antigenic. Antigens are usually large foreign molecules such as proteins and polysaccharides. In general not the entire antigen, but certain parts of a large antigen molecule act as the triggers for the acquired immune responses. The small accessible portion of the antigen that binds to a specific antigen receptor of a T lymphocyte or B lymphocyte is called an epitope (for exp a group of amino acids in a large protein). Can serve as an epitope. Usually a single antigen has several epitopes (Figure 5.32) each can bind with a specific antigenic receptor of the single T or B lymphocyte.



*Figure 5.32: (a). Mature T lymphocyte and mature B lymphocyte with antigen receptors on the plasma membrane, (b). B cell receptor binds with an Epitope on antigen*

In acquired immunity, two types of immune responses are mediated by T lymphocytes and B lymphocytes. They are Cell mediated immune responses and Humoral immune responses. Humoral immune response is also called as Antibody mediated immune response. Both immune responses are triggered by antigens. A given pathogen may provoke both types of immune responses.

### **Cell mediated immune response**

Cell mediated immune response is a type of acquired immunity in which specifically sensitized T lymphocytes attach to the antigen undergo proliferation and eventually differentiate into “Cytotoxic T cells” that can directly kill the cells with the invading antigen. In addition “Memory T cells” are formed that can cause stronger and more rapid response at the subsequent encounter of the same antigen to the body. This is particularly effective against infected cells (fungi, parasites and virus that are present within host cells), some cancer cells and foreign transplanted cells. Cell mediated immunity always involves cells attacking cells.

### **Humoral immune response**

Humoral immune response is a type of acquired immunity in which specifically sensitized B lymphocytes attach to a particular antigen undergo proliferation and eventually differentiate into “Plasma cells” that secrete circulating antibodies that can neutralize and inactivate the specific toxins and pathogens in the blood and lymph. In addition “Memory B cells” are formed that can cause stronger and more rapid response at subsequent encounter of the same antigen. Humoral immune response works mainly against antigens present in body fluids and extracellular pathogens (mainly bacteria) that multiply in the body fluids.

### **Antibodies**

Antibodies are proteins secreted by plasma cells (differentiated B lymphocytes) in response to specific antigens; the antibody binds with that antigen to neutralize, inhibit or destroy it. Antibodies can neutralize and inactivate the specific toxins and pathogens in the body fluids. The antibodies do not directly kill the pathogens but can interfere with activity of the pathogen or mark the pathogen for inactivation and destruction. Antibody-antigen complexes can activate complement system and phagocytosis to destroy the pathogen. Antibodies are also called as immunoglobulins. Immunoglobulin has the same Y shaped structure as B lymphocyte antigen receptors but are secreted than membrane bound.

**Role of T lymphocytes and B lymphocytes in acquired immunity****Recognition of the antigen, binding to the antigen and sensitization:**

For an acquired immune response to occur, some T lymphocytes or B lymphocytes must first recognize that a foreign antigen is present in the body. Even though there are vast variety of antigen receptors present on different B lymphocytes and T lymphocytes, only a very small fraction are specific for a particular epitope. Hence, antigen should be presented to the B lymphocytes and T lymphocytes until a match is made. Recognition of the antigen occurs through successful match between an epitope of the antigen and an antigen receptor on small number of B lymphocytes or T lymphocytes. As specific antigen receptors produced by a single T cell or B cell can be identical they can bind to the same epitope. Hence, both T and B cells can respond to any pathogen that produces molecules containing that same epitope. But B cells and T cells encounter antigens in different ways. T lymphocytes only recognize the fragments of antigenic proteins that are presented to the cells by a special cells called “antigen presenting cells” (macrophages, dendritic cells and B cells). However, B lymphocytes can recognize and bind to the antigens present in blood plasma, lymph and interstitial fluid. The binding of an antigen to the specific antigen receptor results in sensitization (activation) of a specific T lymphocyte or B lymphocyte which initiates cell mediated and antibody mediated immune response as described below.

**Proliferation and differentiation into Effector cells:** Once activated the T lymphocyte or B lymphocyte undergoes multiple cell divisions (proliferations) resulting a clone, a population of cells that are identical to the original lymphocyte. Some cells of clones become Effectors cells which are short lived cells that take effect immediately against antigen to provide primary immune responses.

**Elimination of invaders:** The effector forms of T lymphocyte are “Cytotoxic T cells” and “Helper T cells”. Cytotoxic T cells use toxic proteins to kill the cells infected with the pathogen. Signals from Helper T cells activate cytotoxic T cells to kill the infected cells. Signals from Helper T cells can also activate B lymphocytes to initiate antibody production. Effector forms of B lymphocytes are “Plasma cells”. A single activated B lymphocyte can form thousands of identical Plasma cells. The plasma cells begin producing and secreting a soluble form of the B lymphocyte antigen receptor (antibodies) in large quantities which are released to the blood and lymph. Hence, circulating antibodies can neutralize and inactivate the specific toxins and pathogens in the body fluids.

**Provide immunological memory:** Following differentiation into Effector T cells (Cytotoxic T cells and Helper T cells), other T lymphocytes in the clones remain as “Memory T cells” which are long lived that can give rise to Effector T cells if the same

antigen is encountered later in the life. Similarly the remaining B lymphocytes in the clones are “Memory B cells” which are long lived that can give rise to Plasma cells if the same antigen is encountered later in the life. These Memory T cells and Memory B cells can cause stronger and more rapid response at subsequent encounter of the same antigen to the body. This immunological memory is called secondary immune responses.

### **Active immunity**

Active immunity is a long lasting immunity mediated by the action of B lymphocytes and T lymphocytes in the body and the resulting B and T memory cells specific for a pathogen. Active immunity can be developed as a result of natural infection of a pathogen or artificial immunization.

### **Naturally acquired active immunity**

Long lasting immunity developed in the body against various infectious diseases in response to natural infections of pathogens is called naturally acquired active immunity. In response to a disease causing agent entering the body naturally for the first time (e.g. Virus of Chickenpox), some T lymphocytes and B lymphocytes in the body become activated and eventually produce specific cytotoxic T cells and antibodies to destroy the pathogen. Memory B cells and T cells produced in this process are long lived that will provide a stronger and rapid immune responses to destroy the particular antigen if the same antigen (e.g. Virus of Chickenpox) is encountered later in the life. In this way the body can resist to subsequent infections of the same antigen.

### **Artificially acquired active immunity**

Long lasting immunity induced artificially in the body against various infectious diseases through vaccination (immunization) of attenuated (virulence-reduced) pathogens is called artificially acquired active immunity. Immunization can be carried out with preparations of antigens (vaccines) from many sources such as killed or weakened pathogens, inactivated bacterial cells or genes encoding microbial proteins. These vaccines act as the antigens and stimulate cell mediated and antibody mediated immune responses leading to production of long lived memory B and T cells to destroy the antigen. If the pathogen from which the antigen was derived, is encountered naturally later in the life, long lived memory cells can provide a stronger and rapid immune responses to destroy the particular pathogen. In general, the antigens used in the vaccines are pretreated to be immunogenic but not pathogenic. For example, BCG vaccine which is used against tuberculosis disease in man, has been prepared from a strain of the attenuated live tuberculosis bacteria. Polio vaccine consists of live attenuated poliovirus strains. Polio vaccine produces antibodies in the blood against polio virus, and in the event of infection, this protects the individual by preventing the spread of poliovirus to the nervous system.

### **Passive Immunity**

Passive immunity is the short term immunity developed within the body due to the transfer of antibodies produced by another individual. Passive immunity provides immediate protection, but the body does not develop memory as passive immunity does not involve recipients' T cells and B cells. Passive immunity persists only until the transferred antibodies last (few weeks to few months). Therefore the recipient is at risk of being infected by the same pathogen later unless they acquire active immunity or vaccination. Passive immunity can be developed as a result of transferring antibodies to the recipient naturally or artificially.

#### **Naturally acquired passive immunity**

Short term antibody mediated immunity for some infectious diseases can be developed within the body of the fetus or nursing infant due to the natural transfer of antibodies produced by the mother. The immunity occurs due to the transfer of antibodies to the fetus blood from mother's blood across the placenta. Antibodies also can pass from mother to the nursing infant through the colostrum and the milk during breast feeding. The baby develops the resistance against some infectious diseases for a short time. In this way the infant may be protected from these diseases until its own immunity system is fully functional. This is known as naturally acquired passive immunity.

#### **Artificially acquired passive immunity**

*Artificially acquired passive immunity* is a temporarily induced defensive protection achieved by the transfer of antibodies artificially to the blood of the recipient from another source. These readymade antibodies can be administered as blood plasma or serum (human or animal), or as injections of pooled human immunoglobulin from immunized donors or as monoclonal antibodies. Passive transfer of antibodies is used to prevent some infectious diseases when infectious agents are suspected to have accidentally entered the body (e.g. readymade human serum antibodies for hepatitis A virus). It is also used in the treatment of several types of acute infections (e.g. readymade human anti-tetanus immunoglobulin for acute conditions of tetanus). Passive immunization is also used to treat poisoning from venomous snake bite (e.g. antivenin, serum prepared from horses that have been immunized against snake venom). Immunity derived from artificially acquired passive immunization lasts for few weeks to four months.

### **Allergies**

Some persons are overly reactive to substances that are tolerated by most other people. Antigens that induce hypersensitive reactions in some persons are called allergens. Exaggerated responses of the body to certain antigens (allergens) are called allergies. Common allergens include pollens, dust, some food (e.g. shellfish), some antibiotics

(e.g. penicillin), venom from honey bees and wasps. Whenever an allergic reaction takes place the tissue injury occurs. The most allergens stimulate production of plasma cells which secrete antibodies specific for the antigen. When the same allergen enter the body later, it become attach to the antibodies specific to the allergen which induce the mast cells to release histamine and other inflammatory chemicals. Acting on a variety of cell types these signals bring about typical allergy symptoms such as sneezing, runny nose, teary eyes and smooth muscle contractions in the airways of the lungs that can result in breathing difficulties. An acute allergic conditions sometimes lead to death of the person due to breathing difficulties and low blood pressure with a few seconds of exposure to an allergen.

### **Autoimmune diseases**

In some persons, the immune system becomes active against particular self-molecules of the body and begins to attack the person's own tissues leading to an autoimmune disease. Possible causes for autoimmune diseases may be genetic factors, gender and unknown environmental triggers. Many autoimmune diseases affect females than males. A variety of mechanisms produce different autoimmune diseases. Some involve the production of autoantibodies that can affect normal functioning of certain body molecules. Some involve activation of Cytotoxic T cells that destroy certain body cells. Examples for autoimmune diseases include Type 1 Diabetes mellitus, Multiple sclerosis and Rheumatoid arthritis. In Type 1 Diabetes mellitus, T cells attack the insulin producing pancreatic beta cells. In Multiple sclerosis, T cells attack myelin sheaths around neurons. In Rheumatoid arthritis, painful inflammations of the cartilage and bones occur as the immune system mistakenly sends antibodies to the lining of the joints, where they attack the tissue surrounding the joints.

### **Immunodeficiency diseases**

Immunodeficiency disease is a disorder in which responses of the immune system to antigens are defective or absent. An immunodeficiency can lead to frequent and recurrent infections and increased susceptibility to certain cancers. An inborn immunodeficiency results from a genetic or developmental defects in the production of immune system cells or specific proteins such as antibodies or proteins of the complement system. Acquired immunodeficiency can be developed later in life due to the exposure to chemicals or biological agents. Drugs used to fight autoimmune diseases or prevent transplant rejections suppress the immune system leading to an immunodeficiency state. The human immunodeficiency virus (HIV), the pathogen that cause Acquired Immunodeficiency Syndrome (AIDS) escapes and attacks the immune system of man. The HIV causes progressive destruction of immune responses in the person leading to frequent infections and increased susceptibility to certain cancers which can cause death.

## Osmoregulation and excretion

Osmoregulation is processes by which organisms control solute concentrations and water balance within the body. Simple unicellular organisms such as *Amoeba*, *Paramecium* etc. use contractile vacuoles for osmoregulation. But animals have developed different structures for osmoregulation. The chemical reactions that occur in organisms result in the formation of waste products, often toxic, which must be disposed in some way. The removal of the nitrogenous metabolite and other metabolic waste products from the body is called excretion. Defecation is not considered under excretion as it involves the removal of undigested food from the gut. In many animals excretory and osmoregulatory systems are linked structurally and functionally.

### Importance and need of osmoregulation and excretion

For effective body functioning and survival animals have to maintain a constant internal environment specially the relative concentrations of water and solutes within favorable limits. Therefore animals need to regulate the chemical composition of body fluids by balancing uptake and loss of water and solutes. Animal cells will swell and burst if water uptake is excessive. On the other hand, animal cells will shrink and die if water loss is high. The driving force of loss of water in animals as in plants is the concentration gradient of solutes across the cell membrane. Animals have evolved different osmoregulatory strategies depending on the environment in which they live for their survival.

Animals have to get rid of toxic products produced during metabolism in order to safeguard the composition of their internal environment. Otherwise these excretory end products become toxic to the body cells. For example protein and nucleic acids are broken down within the body cell during metabolism and the amine group is converted to ammonia which is highly toxic. Ammonia also acts as a weak base. Oxidation of glucose during metabolism will release  $\text{CO}_2$  which is a weak acid. Accumulation of such weak acids and bases will alter the acid base balance in the internal environment. Changes in acid base balance will lead to adverse effects such as denaturation of proteins. Therefore removal of excretory products from the body is essential to maintain the internal environment within favorable limits for effective body functioning and survival.

### Relationship between metabolic substrates and excretory products

Metabolic substrates in the cells are carbohydrates, fats, proteins and nucleic acids. The excretory products of these substrates will vary depending on several factors such as the chemical structure and the composition, availability of enzymes, oxygen availability and the habitat in which they live.

When carbohydrates are metabolized within the body cells when oxygen is available final excretory end products are  $\text{CO}_2$  and water. If they are subjected to anaerobic respiration in general lactic acid is produced.

When fats are subjected to aerobic metabolism final excretory products are  $\text{CO}_2$  and water. Since proteins contain amine groups in their structure, during metabolism of excess amino acids ammonia is produced. Since nucleic acids contain nitrogenous bases ammonia is produced as an excretory product during their metabolism. Depending on the habitat and the availability of enzymes ammonia will be further converted to other nitrogenous waste products such as urea and uric acid.

### **Relationship between the nitrogenous excretory products and living environment**

Nitrogenous excretory products of animals are ammonia, uric acid and urea. These different forms vary significantly in their toxicity and the energy costs of producing them.

Since ammonia is highly toxic, a large volume of water is needed to excrete ammonia. Therefore typically the organisms that live in water such as bony fishes, many aquatic invertebrates and aquatic amphibians specially tadpoles excrete ammonia since they have ready access to water. Energy cost for producing ammonia for excretion is comparatively low.

Terrestrial animals do not have access to sufficient water to excrete ammonia as the main excretory product. Instead most terrestrial animals such as mammals and adult amphibians mainly excrete urea as the main nitrogenous excretory product. Urea is less toxic. However animals must expend more energy to produce urea from ammonia. Some marine fishes such as sharks also excrete urea (which they use for osmoregulation) as the main nitrogenous waste.

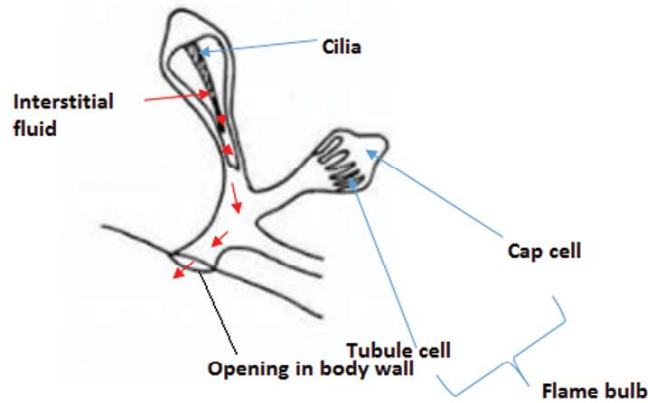
Some terrestrial animals such as birds, many reptiles, land snails and insects excrete uric acid as the main excretory product. Uric acid is relatively non-toxic and generally insoluble in water Therefore it is excreted as a semisolid with trace amount of water. However uric acid production from ammonia requires more energy than urea production

**The diversity of excretory structures of animals** (Fine structures are not necessary)

**Body Surface** - The cells of some animals which are in direct contact with the environment and eliminate excretory products by diffusion. e.g. cnidarians

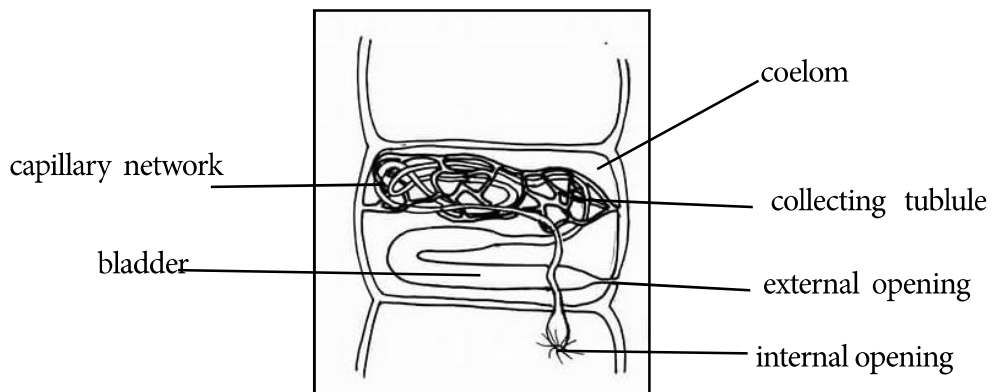


**Flame cells**- These are specialized excretory cells connected to a network of tubule which opens to the outside of the animal. E.g. flatworms.



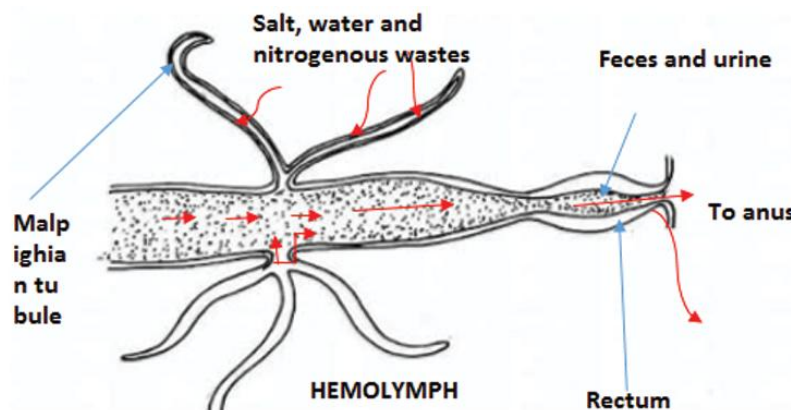
*Fig 5.33: Structure of the flame cell*

**Nephridia** – They are multi cellular, tubular structures. One end of the tubule is open to the coelom while the other end opens to the outside. e.g. Annelids



*Fig 5.34: Structure of the nephridia*

**Malpighian tubules** – These are extensive blind end tubules immersed in hemolymph and opens in to the digestive tract. e.g.: Insects and other terrestrial arthropods



*Fig 5.35: Malpighian tubules*

**Green glands / Antennal glands** –Two large glands found ventrally in the head and anterior to the oesophagus. e.g. Crustaceans

**Sweat glands** –There are coiled tubular glands situated in the dermis and connected to a sweat duct which open as a pore on the surface of the skin. E.g. human skin.

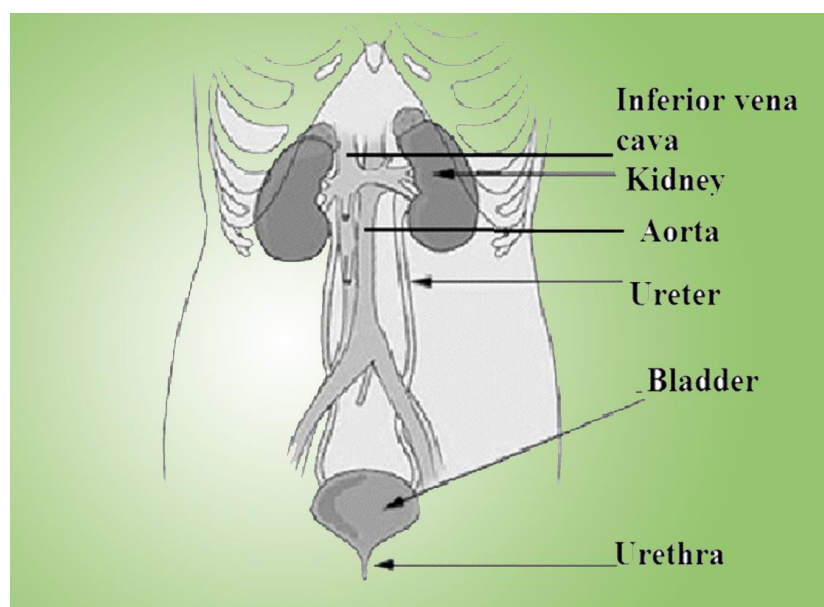
**Salt glands** –They are paired glands found near the eyes to excrete excess salts. e.g. Marine birds and marine reptiles.

**Kidney** – These are the major excretory and osmoregulatory organs of all vertebrates.

### Human Urinary System

Human urinary system consists of two kidneys, two ureters, urinary bladder and urethra. Their main functions are given in the following table;

Part	Main Function
Kidney	Produce urine to excrete waste products while maintaining osmotic balance and acid base balance.
Ureter	Receives urine from kidney and send it to bladder
Urinary bladder	Temporary storage of the urine
Urethra	Provide the passage through which urine stored in the bladder leaves the body



*Fig 5.36: The parts of the human urinary system*

### Location of kidneys

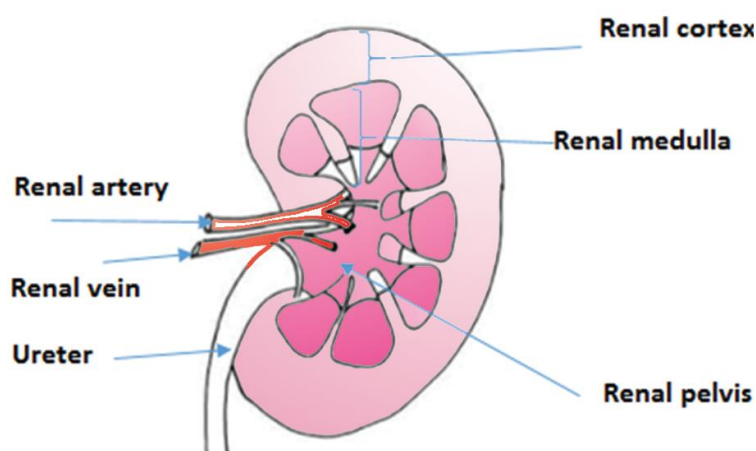
Two kidneys are located on the posterior abdominal wall one on either side of the vertebral column, behind the peritoneum and below the diaphragm. Right kidney is slightly lower than the left.

### Blood supply

The kidneys receive blood from aorta via the renal arteries and renal veins return blood to the inferior vena cava.

### Gross structure of the kidney

Kidney is a bean shaped organ which is held in position by a mass of fat and both are surrounded by a fibrous connective tissue. In the longitudinal section of the kidney three areas of tissues can be seen to the naked eye. They are outer fibrous capsule, renal cortex and inner renal medulla. Cortex and medulla are supplied with blood vessels and tightly packed with excretory tubules. Renal Cortex is granulated due to the presence of glomeruli. Medulla is composed of renal pyramids, which have striated appearance. Apices of pyramids project in to the renal pelvis through renal papillae. Renal pelvis leads into the ureter. Renal artery and renal vein pass through the pelvis.



*Fig 5.37: Longitudinal section of human Kidney*

### Structure of Nephron

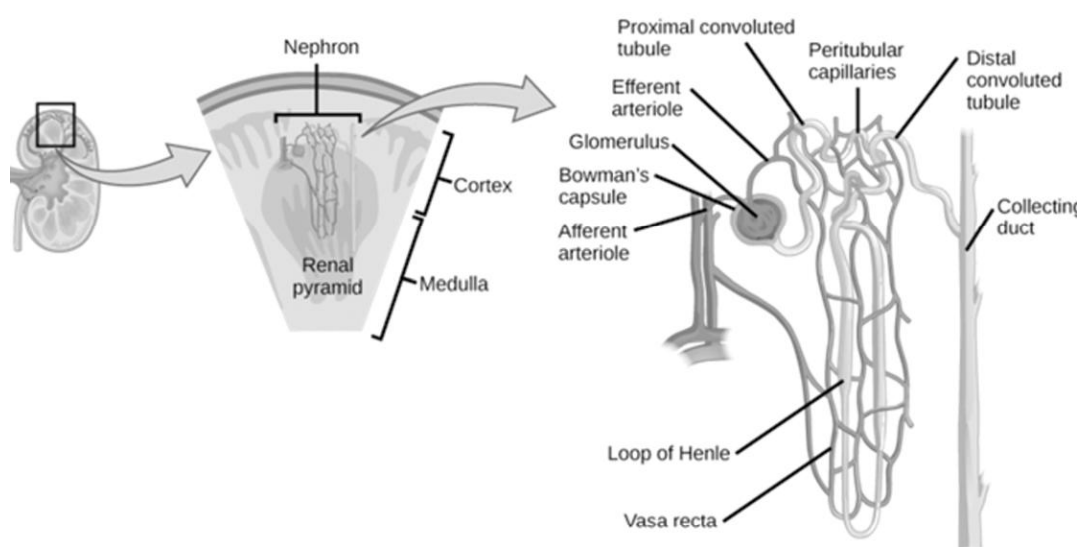
Nephron is the structural and functional unit of the kidney. There are over millions of nephrons in each kidney. There are two types of nephrons; they are cortical nephrons (reach short distance to the medulla) and juxta medullary nephrons (extend deep into the medulla).

Majority of the nephrons are cortical nephrons.

A nephron consists of a single long tubule and a ball of capillaries called the glomerulus. The tubule is closed at one end forming Bowman's capsule which surrounds the glomerulus. The other end of the tubule joins with the collecting duct.

Tubule consists of;

- Bowman's capsule
- Proximal convoluted tubule
- Loop of Henle
- Distal convoluted tubule



*Fig 5.38: A nephron and associated blood vessels*

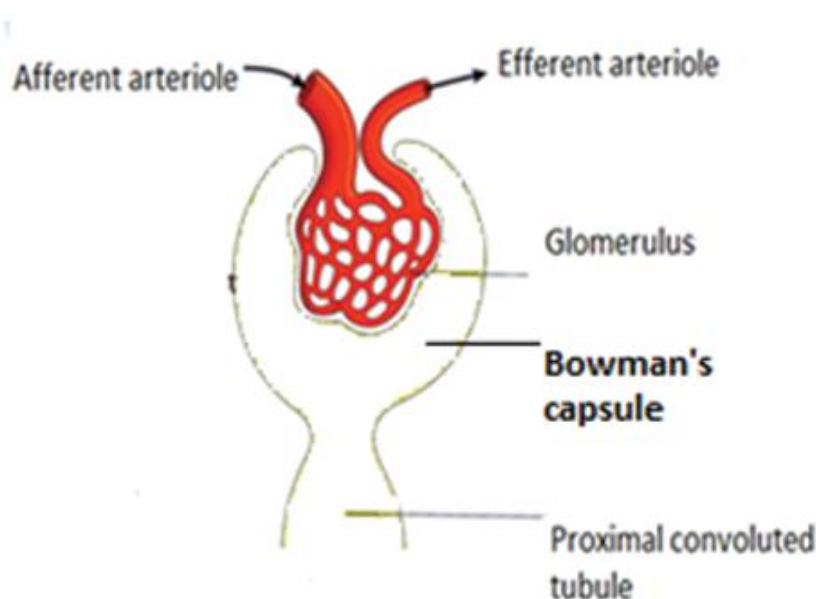
### **Bowman's capsule (Glomerular capsule)**

This is expanded and closed end of the tubular structure of the nephron. It is a cup shaped and double walled structure. Inner layer of Bowman's capsule consists of a single layer of flattened epithelial cells specialized for filtration. Outer layer of the Bowman's capsule composed of simple squamous epithelium. Space between the inner and outer layers is known as capsular space which is responsible for receiving of glomerular filtrate. The glomerular filtrate pass through three major tubular regions of the nephron: proximal convoluted tubule, loop of Henle and distal convoluted tubule.

## Glomerulus

The glomerulus is a ball of capillaries which is surrounded by Bowman's capsule. The nephron is supplied with blood from the afferent arteriole. The blood vessel leaving away from the glomerulus is the efferent arteriole. The efferent arteriole has a smaller diameter than the afferent arteriole. This modification is important for increasing blood pressure in the glomerulus for ultrafiltration.

The efferent arteriole form two capillary networks, one form the peritubular capillaries which surrounds the proximal and distal convoluted tubules and the other network form the vasa recta which extend towards the medulla surrounding the loop of Henle.



*Fig 5.39 The Glomerulus and the Bowman's capsule*

## Proximal convoluted tubule

It is comparatively longer and wider than the distal convoluted tubule. This is lined by simple epithelium which has been specialized for selective reabsorption of substances (nutrients, ions and water) from the glomerular filtrate

## Loop of Henle

It is a 'U' shaped part of the nephron with descending limb and ascending limb which are lined by simple epithelium.

Lining of the descending limb of loop of Henle is specialized for water reabsorption as it allows free movement of water. But lining of the ascending limb of loop of Henle is impermeable to water.

**Distal convoluted tubule**

It is lined by simple epithelium which has been specialized for selective reabsorption of specific ions and water. It leads into collecting duct.

**Main steps in urine formation**

There are 3 processes involved in urine formation. They are;

- ultrafiltration
- selective reabsorption
- secretion

**Ultra filtration**

- Filtration of the blood under high pressure into the cavity of the Bowmans' capsule is called ultrafiltration.
- Filtration occurs through the capillary walls of glomerulus and inner wall of Bowman's capsule.
- Blood capillaries of glomerulus are porous and cells lining the Bowmans' capsule are specialized for filtration of small size molecules and ions. These specializations allow passage of water and small solutes through the blood capillary walls into the Bowman's capsule. But due to their large size, blood cells, platelets and large molecules such as plasma proteins do not pass into the Bowmans' capsule.
- The filtrate in the Bowmans' capsule contains salts, amino acids, glucose, vitamins, nitrogenous wastes and other small molecules. The composition of the glomerular filtrate is similar in composition to plasma with exceptions of blood cells, platelets and plasma proteins.

**Selective reabsorption**

- The process through which useful molecules, ions and water from the glomerular filtrate are recovered and returned to the interstitial fluid and then into capillary network of the tubules is called selective reabsorption.
- Most of the reabsorption from the glomerular filtrate back into the blood takes place in the convoluted tubule. Ions, water and valuable nutrients are reabsorbed either active or passive transport from initial filtrate.

**Secretion**

- The process by which foreign materials and substances not required to the body including waste are cleared from the peritubular capillaries and interstitial fluid into the filtrate is called secretion

- Secretion is required because such substances may not be entirely filtered due to the short time they remain in the glomerulus.
- Substances that are secreted in to the filtrate include  $H^+$ ,  $NH_3$ , creatinine, drugs (e.g. penicillin, aspirin) and excess  $K^+$ . Tubular secretion of  $H^+$  and  $NH_3$  are important to maintain the normal pH in the blood by formation of  $NH_4^+$  in the urine.  $NH_3$  can combine with  $H^+$  to form  $NH_4^+$
- Secretion occurs in the proximal and distal convoluted tubules. Secretion may be either active or passive depending on the location and / or the substance.

### Process of urine formation

Glomerular filtrate in the Bowman's capsule which contains all the substances in the blood except blood cells, platelets and large molecules pass to the proximal convoluted tubule. At this region selective reabsorption of ions, water and valuable nutrients from the initial filtrate occurs. Nutrients especially glucose and amino acids are actively transported to the interstitial fluid. Cells lining the tubule actively transport  $Na^+$  into the interstitial fluid and this transfer a positive charge out of the tubule drives the passive transport of  $Cl^-$ . Proximal tubule also reabsorbs  $K^+$  and most of the  $HCO_3^-$  by passive transport. Reabsorption of  $HCO_3^-$  in the filtrate contributes to the pH balance in body fluids. As solutes move from the filtrate to interstitial fluid water is reabsorbed passively by osmosis. A major portion of water reabsorption from the filtrate occurs at this site. As the filtrate pass through the proximal convoluted tubule, secretion of specific substances into the filtrate takes place. Cells lining the tubule secrete  $H^+$  (by active transport) and ammonia (by passive transport) into the lumen of the tubule. Secreted ammonia act as a buffer to trap  $H^+$  forming  $NH_4^+$ . In addition some materials such as drugs and toxins that have been metabolized in the liver are actively secreted into the lumen of the proximal convoluted tubule. As a result of water reabsorption and secretion of different substances, the filtrate becomes more concentrated as it passes through the proximal convoluted tubule.

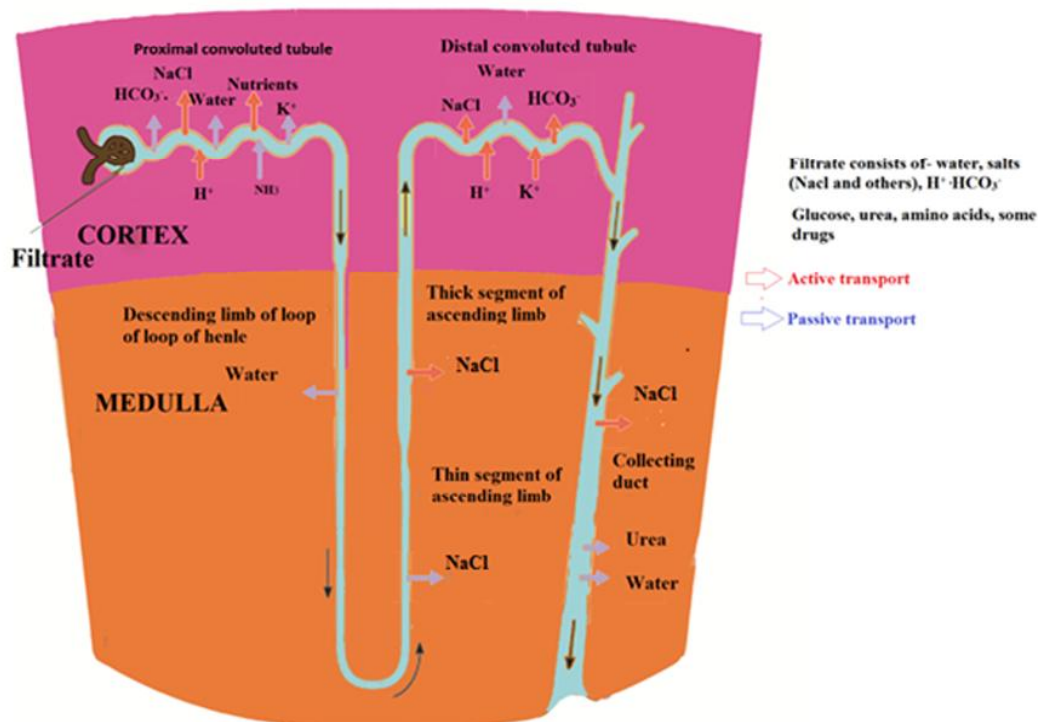
As the filtrate moves into the descending limb of loop of Henle passive reabsorption of water through osmosis continues and filtrate becomes more concentrated. The filtrate reaches the ascending limb of the loop of Henle via the tip of the loop. Ascending limb is impermeable to water so that no water absorption takes place but a considerable amount of  $NaCl$  reabsorption occurs at this site. Most of the  $Na^+$  is transported into the interstitial fluid by active transport. As a result of losing  $NaCl$  but not water the filtrate become more diluted as it moves towards the distal convoluted tubule.

The distal convoluted tubule plays an important role in regulating  $K^+$  and  $NaCl$  concentration of body fluids. The amount of  $K^+$  secreted (by active transport) into the filtrate and the amount of  $NaCl$  (by active transport) reabsorbed from the filtrate can be varied at this site according to the needs of the body. Distal tubule also contributes

to pH regulation by controlled secretion of  $H^+$  and reabsorption of  $HCO_3^-$ . At the distal convoluted tubule passive water reabsorption can be increased under the influence of Antidiuretic hormone (ADH) to form concentrated urine. Aldosterone secreted by the adrenal gland stimulates increase reabsorption of  $Na^+$  and water and excretion of  $K^+$ . This filtrate of the distal convoluted tubule finally leads to the collecting duct.

As the filtrate pass along the collecting duct filtrate become concentrated and urine is formed. At this site water reabsorption can also be increased under the influence of ADH and urine become more concentrated. Aldosterone hormone stimulates active reabsorption of  $Na^+$  and passive reabsorption of water at the collecting duct. Because of the high urea concentration in the filtrate at this region some urea diffuses into the interstitial fluid. Final processing of the filtrate at the collecting duct forms the urine.

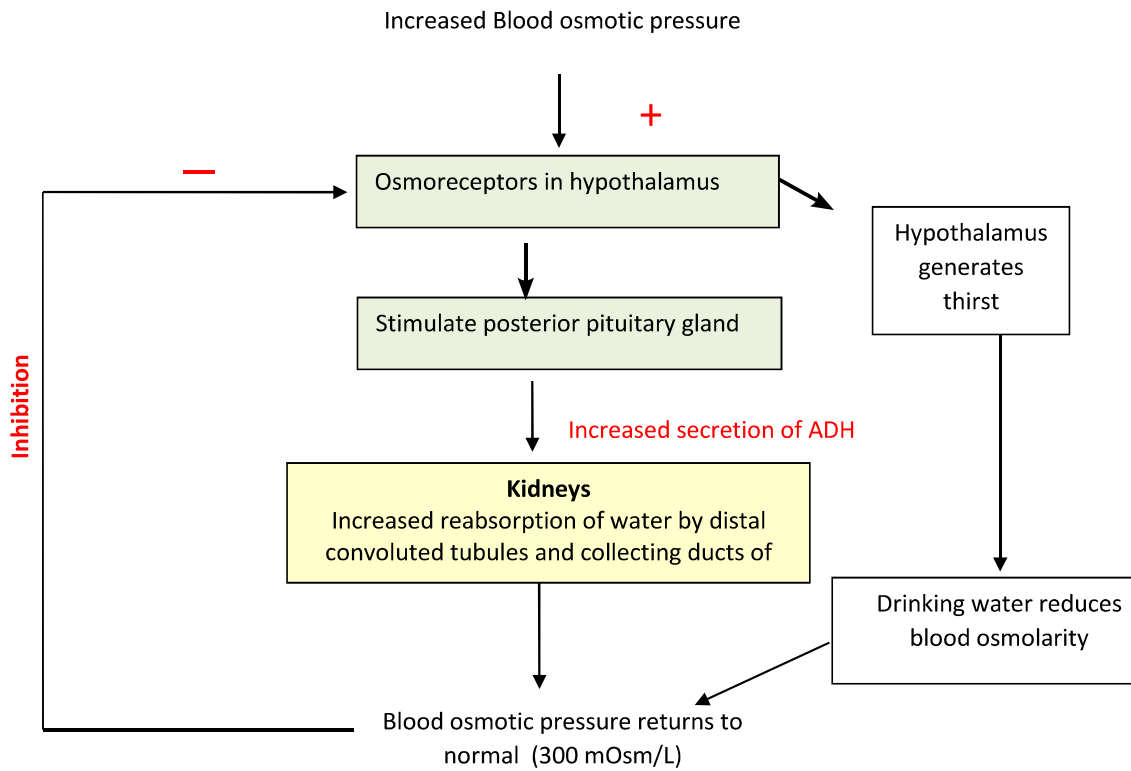
When producing dilute urine the kidney actively reabsorb salts without allowing water to be reabsorbed by osmosis.



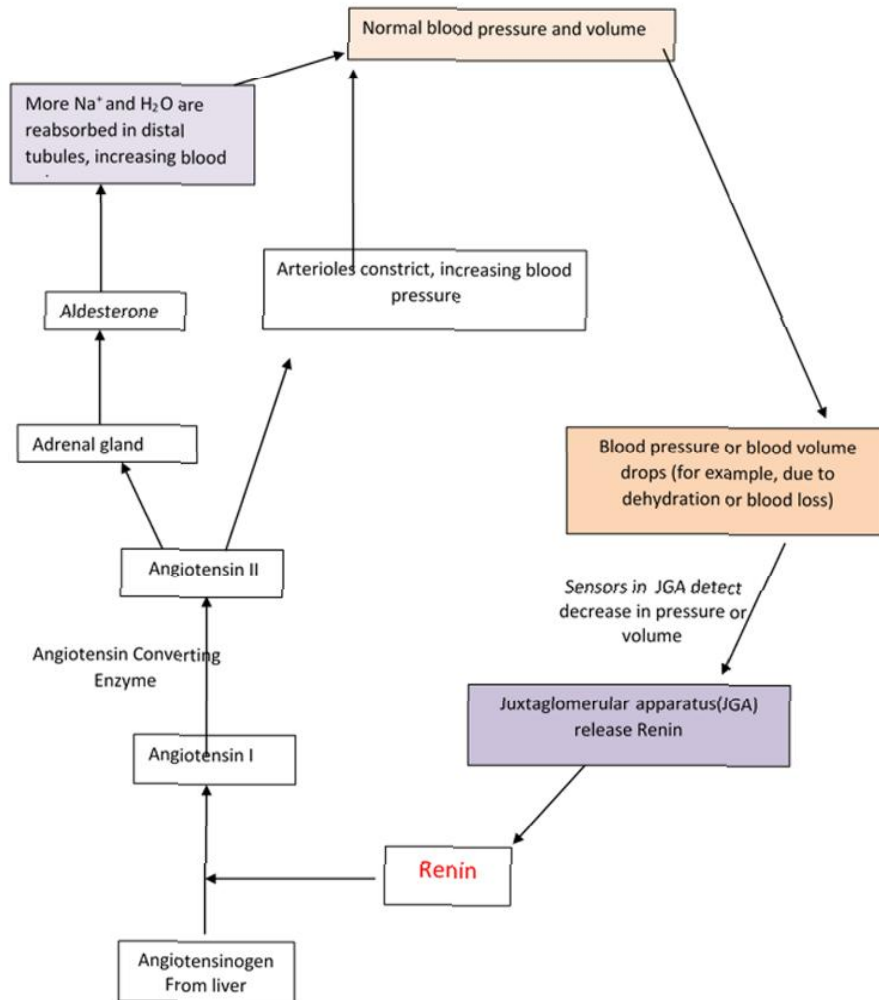
*Fig 5.40 Reabsorption and secretion of different molecules and ions in the nephron and formation of urine in the collecting duct*



**Role of hormones on the functions of the kidney**



**Fig5.41 Regulation of blood osmotic pressure and fluid retention in the kidney by ADH**



**Fig5.42: Regulation of blood osmotic pressure and fluid retention in the kidney by ADH**

**Role of kidney in homeostasis**

- Maintaining electrolyte and water balance in the body fluids (osmoregulation).
- Excretion of toxic waste products from the body.
- Regulating blood pH through acid base balance.
- Controlling blood volume and blood pressure.
- Secretion of erythropoietin hormone that stimulates red blood cell production.
- Production and Secretion of renin an enzyme important in control of blood pressure.

**Disorders related to human urinary system****Bladder and kidney stones**

These are formed due to precipitation of urinary constituents (usually oxalates and phosphates) normally in urine. They are also called renal calculi.

Causes include

- Dehydration due to not drinking sufficient amount of fluids.
- Alkaline nature of urine.
- Infections that can alter pH of urine
- Metabolic condition.
- Family history.

**Measures for prevention**

- Drinking plenty of water

**Kidney failure**

This is due to the inability of the kidneys to function properly. Therefore waste products and excess fluid will be accumulated in the blood.

**Reasons for kidney failure**

- Diabetes
- High blood pressure
- Having family history
- Getting older

**Chronic kidney disease (CKD)**

It is a condition of gradual loss of kidney function over time. There are many reasons for Kidney failure:

- Diabetes
- High blood pressure

- Having family history
- Getting older

### **Prevent CKD**

Follow a low salt, low fat diet

Doing proper exercise

Having regular check ups

Prevent smoking

### **Dialysis**

Dialysis is done for the patients with kidney failure. It is a process of removing excretory products, excess solutes and toxins from the blood by an artificial method.

### **Chronic kidney disease of unknown/uncertain etiology (CKDu) in Sri Lanka**

- It is a condition of gradual loss of kidney function over time. The root cause of CKDu has not been definitively established yet – hence it is referred to as ‘Chronic kidney disease of unknown/uncertain etiology’. However it is a different form of chronic kidney disease (CKD), which is associated with conventional risk factors such as diabetes and high blood pressure, genetic disorders and urinary tract problems
- 
- The onset of the disease appears to be asymptomatic, and by the time the patient seeks treatment the kidneys have reached a stage of irreversible damage -end stage renal disease (ESRD).
- In Sri Lanka, initially CKDu was prevalent among rural communities in North Central province (Medawachchiya, Kabithigollawa, Padaviya, Medirigiriya, regions), Uva (Girandurukotte), Eastern Provinces (Dehiattakandiya). CKDu is also reported in North Western, Southern and Central provinces, and parts of the Northern Province of the island.

### **Hypothesized reasons for CKDu**

Cause of CKDu seems to be multifactorial.

- Exposure to Heavy metal/ metalloid such as Arsenic (As) and Cadmium (Cd) through food and water.
- Usage of low quality utensils for preparation of foods.
- High Flouride (F) levels in water.
- Exposure to pesticides.
- Genetic factors.
- Malnutrition and dehydration.

**Notes:**

**This is to acknowledge that some of the diagrams used in this book have been taken from various electronic sources using internet . This book is not published to make profit and sold only to cover cost.**

**The resource book is prepared according to the subject content and learning outcomes of the G.C.E. (A.L) Biology new syllabus which is implemented from 2017.**

**The content of this Resource book declares the limitation of the G.C.E. (A.L) Biology new syllabus which is implemented from 2017.**

**References**

1. Biology ,A Global Approach, 10th edition (by Campbell Reece, Urry, Cain, Wasserman. Minorsky, Jackson)
2. Ross and Wilson Anatomy and physiology in Health and Illness (12th edition by Anne Waugh and Allison Grant)