

**G. C. E. (Advanced Level)
PHYSICS
Resource Book**

Grade 12

Unit 4: Thermal Physics

**Department of Science
Faculty of Science and Technology
National Institute of Education
www.nie.lk**

G. C. E. (Advanced Level)
PHYSICS
Grade 12
Unit 4: Thermal Physics

© National Institute of Education
First Print – 2020

ISBN 978 - 955 - 654 - 899 - 0

Department of Science
Faculty of Science and Technology
National Institute of Education
Sri Lanka

Published by: Press
National Institute of Education
Maharagama
Sri Lanka

Printed by: Sisara Printway (Pvt) Ltd,
No. 110, Pagoda Road,
Pitakotte.

Message from the Director General

The National Institute of Education takes opportune steps from time to time for the development of quality in education. Preparation of supplementary resource books for respective subjects is one such initiative.

Supplementary resource books have been composed by a team of curriculum developers of the National Institute of Education, subject experts from the national universities and experienced teachers from the school system. Because these resource books have been written so that they are in line with the G. C. E. (A/L) new syllabus implemented in 2017, students can broaden their understanding of the subject matter by referring these books while teachers can refer them in order to plan more effective learning teaching activities.

I wish to express my sincere gratitude to the staff members of the National Institute of Education and external subject experts who made their academic contribution to make this material available to you.

Dr. (Mrs.) T. A. R. J. Gunasekara
Director General
National Institute of Education
Maharagama.

Message from the Director

Since 2017, a rationalized curriculum, which is an updated version of the previous curriculum is in effect for the G.C.E (A/L) in the general education system of Sri Lanka. In this new curriculum cycle, revisions were made in the subject content, mode of delivery and curricular materials of the G.C.E. (A/L) Physics, Chemistry and Biology. Several alterations in the learning teaching sequence were also made. A new Teachers' Guide was introduced in place of the previous Teacher's Instruction Manual. In concurrence to that, certain changes in the learning teaching methodology, evaluation and assessment are expected. The newly introduced Teachers' Guide provides learning outcomes, a guideline for teachers to mould the learning events, assessment and evaluation.

When implementing the previous curricula, the use of internationally recognized standard textbooks published in English was imperative for the Advanced Level science subjects. Due to the contradictions of facts related to the subject matter between different textbooks and inclusion of the content beyond the limits of the local curriculum, the usage of those books was not convenient for both teachers and students. This book comes to you as an attempt to overcome that issue.

As this book is available in Sinhala, Tamil, and English, the book offers students an opportunity to refer the relevant subject content in their mother tongue as well as in English within the limits of the local curriculum. It also provides both students and teachers a source of reliable information expected by the curriculum instead of various information gathered from the other sources.

This book authored by subject experts from the universities and experienced subject teachers is presented to you followed by the approval of the Academic Affairs Board and the Council of the National Institute of Education. Thus, it can be recommended as a material of high standard.

Dr. A. D. A. De Silva
Director
Department of Science

Guidance

Dr. (Mrs.) T. A. R. J. Gunasekara

Director General - National Institute of Education

Supervision

Dr. A. D. A. De Silva

Director, Department of Science
National Institute of Education

R. S. J. P. Uduporuwa

Former Director, Department of Science
National Institute of Education

Internal Editorial Panel

- P. Malavipathirana - Senior Lecturer, National Institute of Education
Dr. M.L.S. Piyathissa - Assistant Lecturer, National Institute of Education
Miss. R.A. Amarasinghe - Assistant Lecturer, National Institute of Education
Mrs. M.R.P.I. Herath - Former Assistant Lecturer - National Institute of Education

Writing Panel

- W.A.D. Rathnasooriya - Former Chief Project Officer, National Institute of Education
B.A. Tilakarathna - Former Project Officer, National Institute of Education
Former SLEAS.-II
H.S.K. Wijeyathilaka - Former SLEAS -I
P. Wickramasekara - SLTS- I, Buddhist Girls' College, Mount Lavinia
S.R. Jayakumar - SLTS-I, Royal College, Colombo 07

External Editorial Panel

- Dr. I.K. Perera - Former Senior Professor of Physics
Sabaragamuwa University of Sri Lanka
Prof. S.R.D. Rosa - Department of Physics, University of Colombo
Prof. L.R.A.K. Bandara - Department of Physics, University of Peradeniya
Dr. P.W.S.R. Bandaranayake - Department of Physics, University of Peradeniya
Dr. M.K. Jayananda - Department of Physics, University of Colombo
Prof. J.C.N. Rajendran - Department of Physics, Open University of Sri Lanka
Dr. D.D.N.B. Daya - Department of Physics, University of Colombo
Dr. J.K.P. Bodika - Department of Physics, University of Ruhuna

Language Editing

- M.A.P. Munasinghe - Former Project Officer,
National Institute of Education

Cover and Setting

- Mrs. R.R.K. Pathirana - Technical Assistant;
National Institute of Education

Supporting Staff

- Mrs.W.P.P. Weerawardana - National Institute of Education
M. Welipitiya - National Institute of Education
K.G.R. Dayawansa - National Institute of Education

Content

Unit 4 Thermal Physics

4.1	Temperature	01
4.2	Thermal expansion of solids and liquids	15
4.3	Gas laws	27
4.4	Kinetic theory of gases	38
4.5	Exchange of Heat	42
4.6	Changes of state	47
4.7	Vapour and humidity	53
4.8	Thermodynamics	64
4.9	Transfer of heat	73
	References	73

Chapter - 01

Temperature

Temperature

We use our sense organs for various observations. We see with our eyes. We hear with our ears. In the same way, we can feel hotness or coldness with our skin. We feel hot when the temperature is high and we feel cold when the temperature is low. Most quantities that can be perceived are physical quantities. Temperature is also such a quantity.

In this chapter, we discuss a number of phenomena associated with temperature and thermal energy. We shall start by developing the idea of “temperature”.

Temperature and flow of heat

When you touch the bulb of a mercury thermometer at room temperature with your fingers, you will see the mercury column rising. This is because heat flows from your finger which is at a higher temperature, to the bulb which is at a lower temperature than that of your finger. Then mercury gets expanded resulting in a rise of the mercury column. So it is clear that heat flows from a location which is at a higher temperature to a location which is at a lower temperature and it is meaningless to talk about an amount of heat which a body contains.

Thermal equilibrium

Consider the flow of heat when two bodies A and B at the same temperature are in thermal contact. We tend to say that there is no flow of heat. In thermodynamics, it is said that there is no net flow of heat between A and B. It is considered that heat flows from A to B as well as from B to A in equal amount per second and hence there is no net transfer of heat. It is a dynamic equilibrium state and is called thermal equilibrium.

Zerth law of thermodynamics

The zeroth law of thermodynamics says that, when two bodies A and B are in thermal equilibrium separately, with another body C, then the bodies A and B are also in thermal equilibrium.

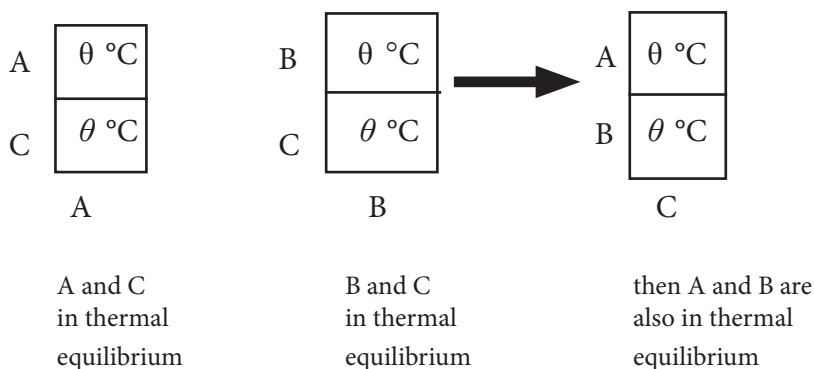

Figure 1.1

When we take a reading from a thermometer we should wait until the thermometer comes to thermal equilibrium with the body with the sensing part of the thermometer (e.g. mercury bulb) is in contact.

The use of a thermometer can be taken as an example for the application of the zeroth law as follows. Suppose the bulb of a liquid-glass thermometer is immersed in a fluid (liquid or gas) and the thermometer gives the reading when it comes to thermal equilibrium. Now if the thermometer gives the same reading in the equilibrium when it is immersed in another fluid, then we can say that the two fluids are at the same temperature.

Here, the first fluid is taken to be the object A and the second fluid is taken to be the object B. The object C is the thermometer showing the reading θ .

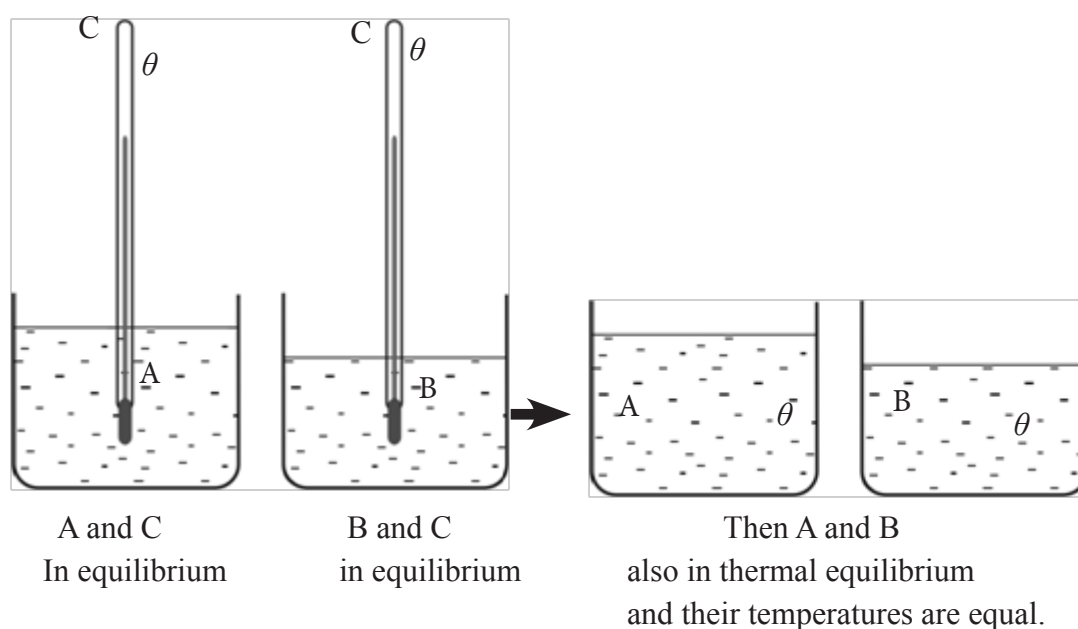

Figure 1.2

Thermometric properties

To measure temperature, there should be some physical property that varies uniformly with temperature. Measurable properties which vary with temperature in a known way and which can be used in measuring temperature are called thermometric properties.

e.g.:

- i. Volume of a fixed mass of mercury
- ii. e.m.f. generated in a thermocouple

Important features of thermometric properties

1. To be a single valued function of temperature

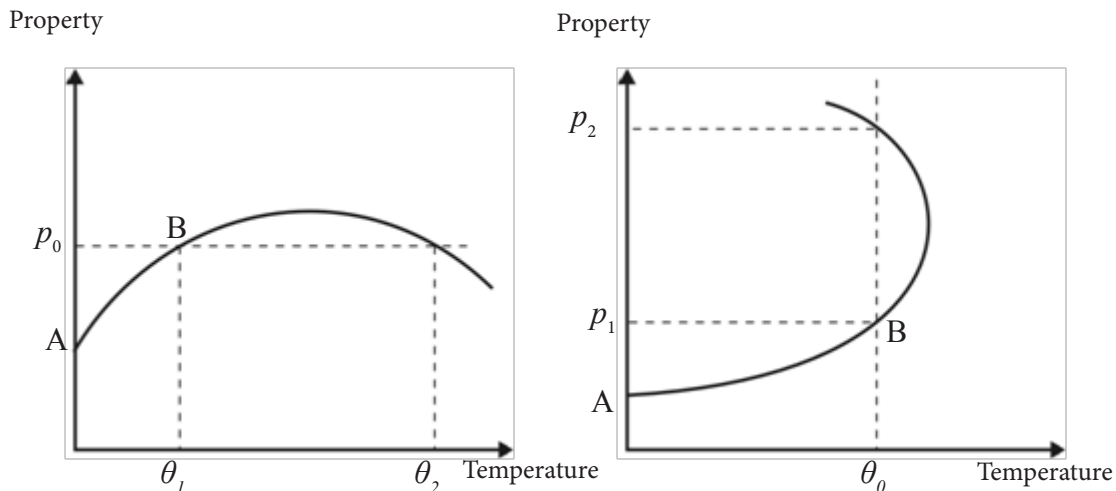

Figure 1.3

The property should not give same value (p_0) for two different temperatures (θ_1 and θ_2) and also it should not give two different values (p_1 and p_2) for the same temperature (θ_0) as shown by above graphs. Even so this property can be used as a thermometric property in a region where it behaves as single valued function of temperature (e.g. in the region A to B in the Figure 4.1.3).

2. To be a continuous function of temperature

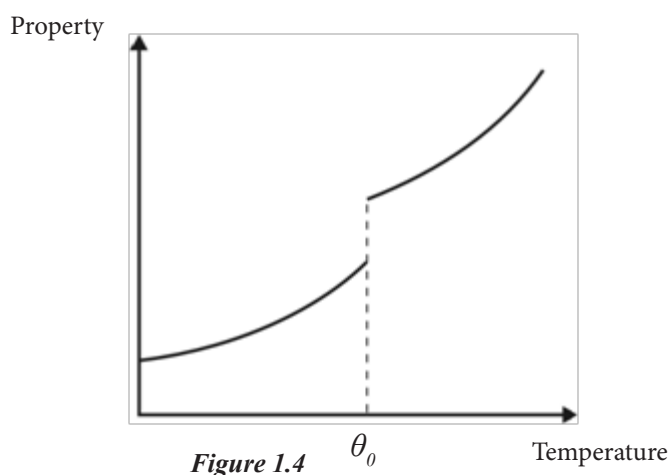

Figure 1.4

It should be continuous and should not be discontinuous as at θ_0 shown by the above graph. In it, at θ_0 thermometric property is uncertain. When there is a change of state of matter such discontinuation may occur.

3. To be a linear function of temperature as far as possible.

An ideal thermometric property should exhibit a linear variation with temperature as shown by the following graphs.

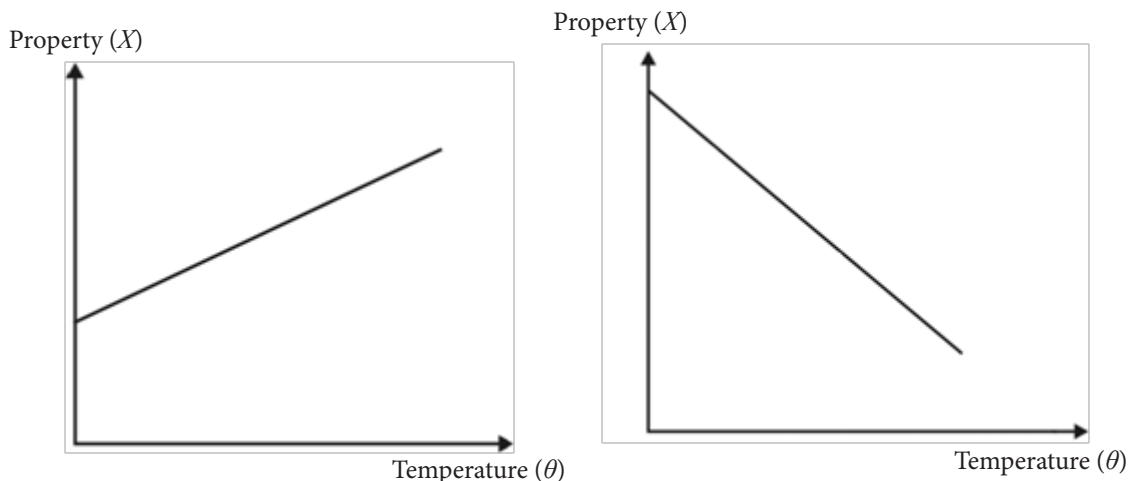

Figure 1.5

Since it is almost impossible to have a practical thermometric property behaving exactly in this manner, a property which is close to this behavior is chosen. It is shown in the following graphs.

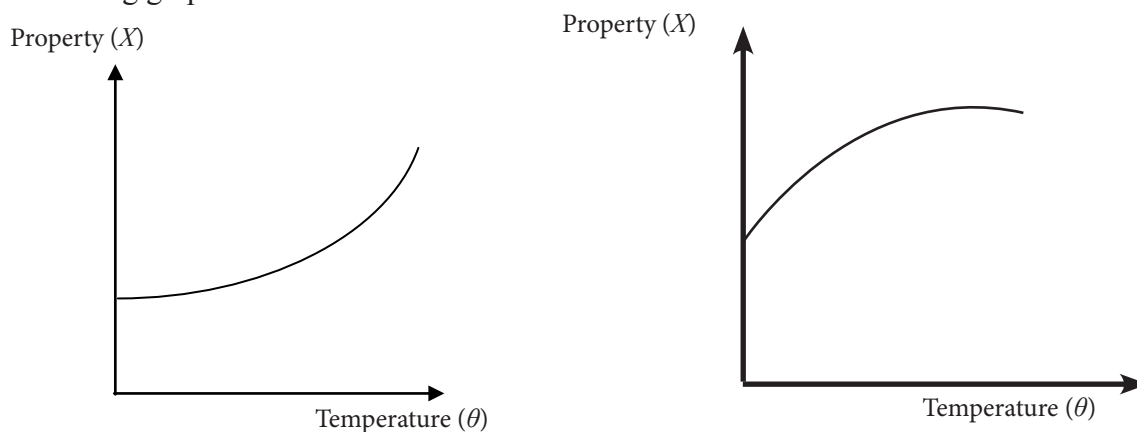

Figure 1.6

Some thermometric properties used in thermometers are,

1. Volume of a fixed mass of mercury.
2. Pressure of a fixed mass of a gas under constant volume.
3. Volume of a fixed mass of gas under constant pressure.
4. e.m.f. generated in a thermocouple.
5. Electrical resistance of a piece of platinum wire.

Measurement of temperature

Let us consider a thermometric property (X) which varies linearly with temperature as (θ) shown in the graph.

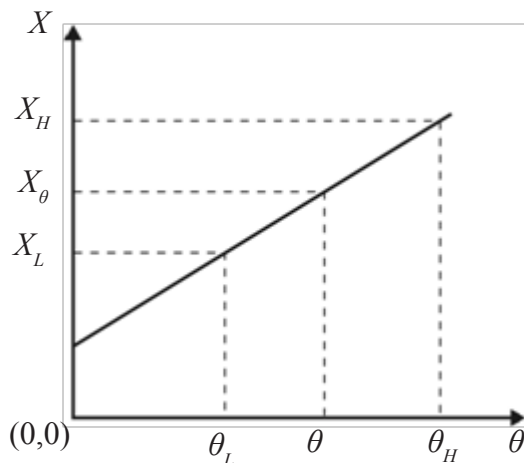

Figure 1.7

Suppose that the values of X relevant to two known fixed temperatures, namely lower fixed point, θ_L and upper fixed point, θ_H are X_L and X_H respectively and at some unknown temperature θ , it is X_θ .

Then by considering the gradient of the graph, we can write

$$\frac{X_\theta - X_L}{\theta - \theta_L} = \frac{X_H - X_L}{\theta_H - \theta_L}$$

$$\theta - \theta_L = \left(\frac{X_\theta - X_L}{X_H - X_L} \right) (\theta_H - \theta_L)$$

$$\therefore \theta = \left(\frac{X_\theta - X_L}{X_H - X_L} \right) (\theta_H - \theta_L) + \theta_L$$

When X_L , X_H and X_θ are known and θ_L and θ_H have definite values, θ can be calculated.

Note: Please note that the above expression is valid only when the thermometric property X varies linearly with the temperature.

Celsius temperature scale

In this temperature scale, θ_L and θ_H are defined to be the fixed temperatures as follows.

- θ_L - Melting point of pure ice at standard atmospheric pressure. This unique temperature has been given the value 0 °C in this scale and is known as the lower fixed point.
- θ_H - Boiling point of pure water at standard atmospheric pressure. This unique temperature has been given the value 100 °C in this scale and is known as the upper fixed point.

Substituting the values of θ_L and θ_H in the above equation we get,

$$\theta \text{ } ^\circ\text{C} = \left(\frac{X_\theta - X_L}{X_H - X_L} \right) \times 100$$

Absolute thermodynamic temperature scale

Consider an ideal thermometric property (X) which varies according to the following graph.

Eg. Variation of pressure of a fixed mass of ideal gas under constant volume.

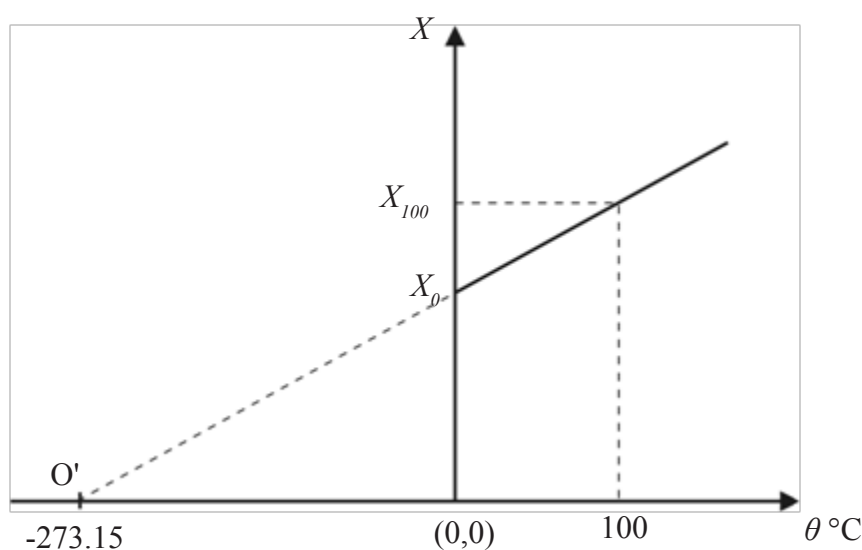

Figure 1.8

When the graph is extrapolated the point O' at which the graph cuts, the temperature axis can be found. The value of temperature at O' is $-273.15 \text{ } ^\circ\text{C}$ (in celsius).

A new temperature scale known as thermodynamic scale was defined taking the point O' as the origin and given the value of zero, known as absolute zero to that temperature. The unit of measurement was taken to be kelvin (K). Usually absolute temperature is denoted by the symbol T . Since this is based on an ideal thermometric property this a theoretical scale. Therefore, it does not depend on the property of any particular substance. But it is identical with the scale base on the pressure variation of an **ideal gas** at constant volume.

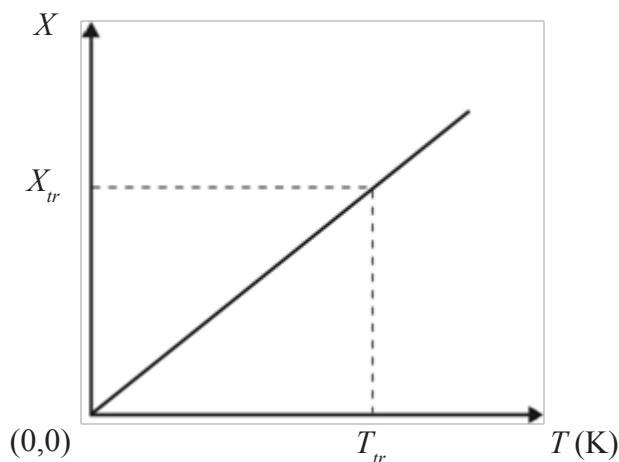

Figure 1.9

As this graph passes through the origin, only one well defined point would be sufficient to draw the line. Therefore in this scale, only one fixed point is enough and that point is known as the triple point of water (T_{tr}).

Triple point of water

The triple point of water is defined to be the temperature at which pure water, water vapour and ice are in thermal equilibrium.

The triple point of water is equal to 273.16 K (in kelvin) and 0.01 °C (in celcius).

Now consider the following graph where the thermal property is X_T at temperature T and X_{tr} at some unknown temperature T_{tr} (T_{tr} is the triple point of water).

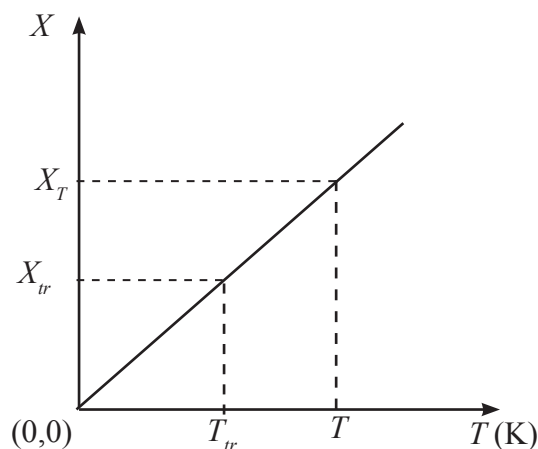

Figure 1.10

Now considering the gradient of the line we can write,

$$\frac{X_{tr}}{T_{tr}} = \frac{X_T}{T}$$

$$\therefore T = \left(\frac{X_T}{X_{tr}} \right) \times T_{tr}$$

Since $T_{tr} = 273.16$

$$T = \left(\frac{X_T}{X_{tr}} \right) \times 273.16$$

Relationship between T and θ

To obtain the relationship between T and θ , let us consider the following diagram.

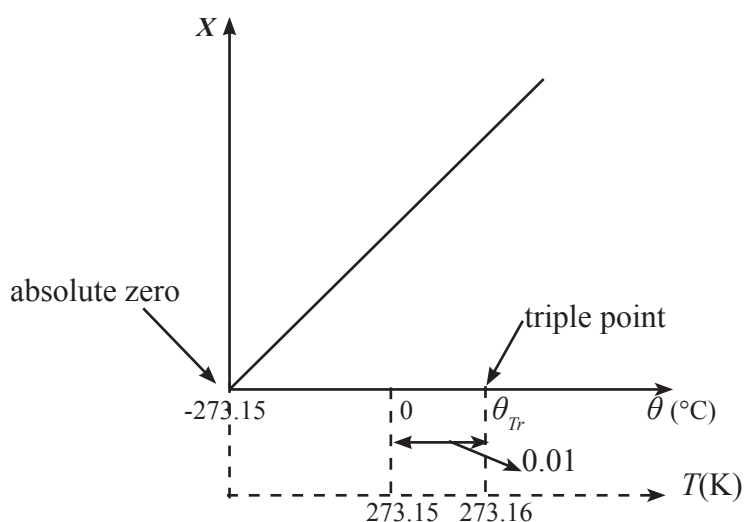

Figure 1.11

No. of °C divisions between ‘absolute zero’ and ‘triple point’ is 273.16.

No. of K divisions between ‘absolute zero’ and ‘triple point’ is 273.16.

Therefore, it is clear that, one division of kelvin = one division of celsius.

So, it is very important to realize that when the difference of temperature ($\Delta\theta$ or ΔT) is concerned, both kelvin value and °C value are equal. It should also be noted that, when a particular single temperature is considered the kelvin value and the °C value are quite different.

We can see from the diagram that,

$$\begin{aligned} 0\text{ }^{\circ}\text{C} &= (273.16 - 0.01)\text{ K} \\ &= 273.15\text{ K} \end{aligned}$$

Now, for any given value of temperature in celsius (θ), suppose that value in kelvin is T . Then it is obvious that

$$T = \theta + 273.15$$

It should be noted that thermodynamic scale is a theoretical scale and also that the absolute zero (0 K) has never been reached.

Worked examples

- Some thermometric property gives its values as 5.0 and 20.0 in relevant units temperatures 0°C and 100°C respectively. When a thermometer which uses above thermometric property, gives the value of that property as 11.0 when measuring the temperature of a liquid. Calculate the temperature of the liquid. Give your answer in $^\circ\text{C}$ and K.

$$\text{Using } \theta = \left(\frac{X_\theta - X_L}{X_H - X_L} \right) \times 100$$

$$\theta = \left(\frac{11.0 - 5.0}{20.0 - 5.0} \right) \times 100 = \frac{6.0}{15.0} \times 100$$

$$= \underline{\underline{40^\circ\text{C}}}$$

$$\text{Using } T = \theta + 273.15$$

$$T = 40 + 273.15 = 313.15 \text{ K}$$

$$\therefore \text{ temperature} = \underline{\underline{313.15 \text{ K}}}$$

- A thermometric property used in a thermometer gives the value 68.29 (in relevant units) at the triple point of water. When this thermometer gives a temperature reading of 300 K, what is the value of thermometric property at that temperature ?

$$\text{Using } T = \frac{X_T}{X_r} \times 273.16$$

$$300 = \frac{X_T}{68.29} \times 273.16$$

$$\therefore X_T = \frac{300 \times 68.29}{273.16} = 75$$

Value of the property = 75 (in relevant units)

3. Complete the following table by filling the blanks.

Occasion	Temperature in °C	Temperature in K
Melting point of water	0
Room temperature	303.15
Temperature of human body	37
Boiling point of water	373.15

Thermometers

There are various types of thermometers. They differ depending on factors such as accuracy, usable range of temperature, sensitivity and response time.

Eg.

- Mercury in glass thermometer (this will be discussed later)
- Constant volume gas thermometer
The thermometric property used in this thermometer is the pressure of a fixed mass of temperature.
- Constant pressure gas thermometer
This thermometer uses the volume of a fixed mass of gas under constant pressure as its thermometric property. The level of accuracy and the range of this thermometer are almost similar to those of constant volume gas thermometer.
- Platinum resistance thermometer
The thermometric property of this thermometer is the electrical resistance of a platinum wire. For this also, temperature range is large and accuracy is high but not as accurate as gas thermometers.
- Thermocouple thermometer
(this will be discussed later)

Mercury- in- glass thermometer

The length of a column of mercury in a glass capillary tube which has a uniform cross section, is the thermometric property of this thermometer.

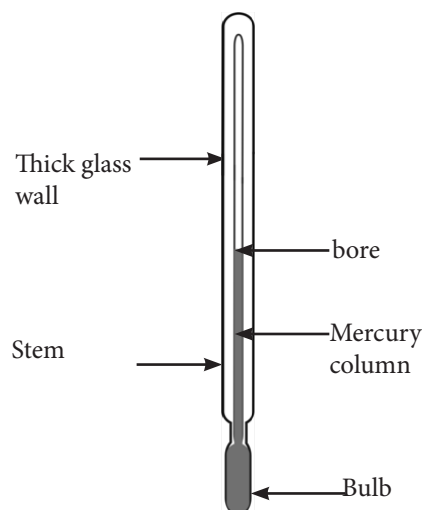

Figure 1.12

Usual range of this thermometer is from $-30\text{ }^{\circ}\text{C}$ to $350\text{ }^{\circ}\text{C}$. By introducing a gas above the mercury column the upper limit can be extended to $500\text{ }^{\circ}\text{C}$.

Advantages of this thermometer

1. Easy to use and easy to transport.
2. Readings can be taken directly.
3. Low cost.
4. Since mercury is a good conductor, heat transfers quickly through the mercury.
5. Since mercury is opaque, it can easily be seen and also it has the quality of not wetting the glass wall of the capillary.

Disadvantages of this thermometer

1. There may be errors due to non uniformity of the bore of the capillary tube.
2. Mercury in the bore is not at the same temperature as that in the bulb.
3. Due to vapour pressure of mercury, there can be errors.
4. Errors may occur due to permanent deformation of the bulb in long term usage.
5. Accuracy is not of higher degree.

Thermocouple thermometer

The thermometric property of this thermometer is the thermoelectric e.m.f developed in a junction of two different metals. For example, a junction made using wires of copper and iron. However to minimize errors, practically, this thermometer consists of two junctions (Figure 1.13). One junction called the cold junction is kept at $0\text{ }^{\circ}\text{C}$ using melting ice. The other junction called the hot junction is kept at a temperature which is to be measured.

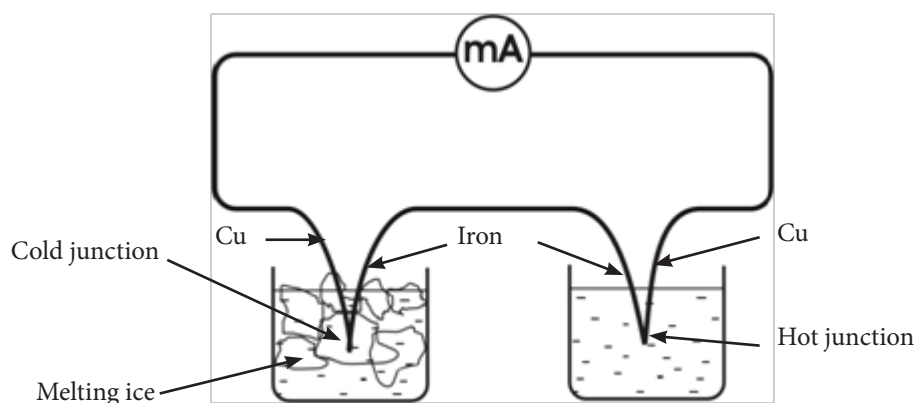

Figure 1.13

Some of the pairs of metal which can be used to make thermocouples are,

1. Copper and iron
2. Nickel and nichrome
3. Platinum and platinum rhodium alloy
4. Copper and constantan

The phenomenon of developing an e.m.f. across a junction of two different metals is called the thermoelectric effect or the Seebeck effect. This e.m.f. is of the order of few millivolts. Therefore, a sensitive millivoltmeter should be used to measure it. For more accurate results, this e.m.f. is measured using a potentiometer. This thermometer has a wide range of about $-200\text{ }^{\circ}\text{C}$ to $1400\text{ }^{\circ}\text{C}$. There are other advantages of using this thermometer.

For example –

1. Thermal capacity of the junction is too small. Therefore, it can be used to measure varying temperatures because of its quick response.
2. Suitable to measure temperature of a small body or a small amount of a liquid.
3. Easy to construct.
4. Able to take direct measurements when a calibrated millivoltmeter is used.

Some of the disadvantages of this thermometer are;

1. Difficulty of using a potentiometer for accurate measurements.
2. Difficulty of maintaining one junction at $0\text{ }^{\circ}\text{C}$.
3. Remarkable non linear behavior at high temperatures as shown by the following figure 1.14 (when temperature $> 400\text{ }^{\circ}\text{C}$).

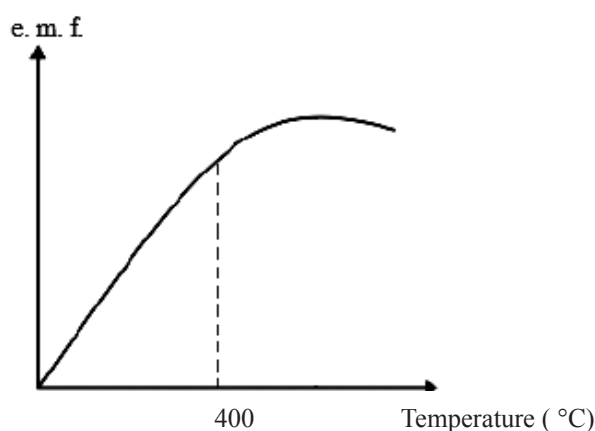

Figure 1.14

Worked example

A mercury in-glass thermometer has a length of 25 cm along its scale from 0 °C to 100 °C . When the bulb is immersed in a liquid, the length of mercury column was 15 cm from the zero mark of the scale. Calculate the temperature of the liquid.

$$\text{Using } \theta = \left(\frac{X_{\theta} - X_L}{X_H - X_L} \right) \times 100 = \left(\frac{15 - 0}{25 - 0} \right) \times 100 = \frac{15}{25} \times 100 = 60$$

$$\therefore \text{Temperature of liquid} = \underline{\underline{60^{\circ}\text{C}}}$$

Thermistor

Thermistor is a device having an electrical resistance which vary with its temperature. Therefore, it can be used as a sensor to detect variation of temperature. Some thermometers are made using thermistors.

Variation of resistance of the thermistor with its temperature can be converted into a voltage or current variation. This variation is fed into an electronic circuit which processes it to indicate temperature using a digital display.

There are two types of thermistors.

1. Thermistors of negative temperature coefficient (NTC type)
In this thermistor, the resistance decreases with the rise of temperature.
2. Thermistors of positive temperature coefficient (PTC type)
In this thermistor, the resistance increases with the rise of temperature.

It should be noted that most of the thermistors used practically are of NTC type. A typical graph of resistance (R) versus temperature for NTC type thermistors shown below.

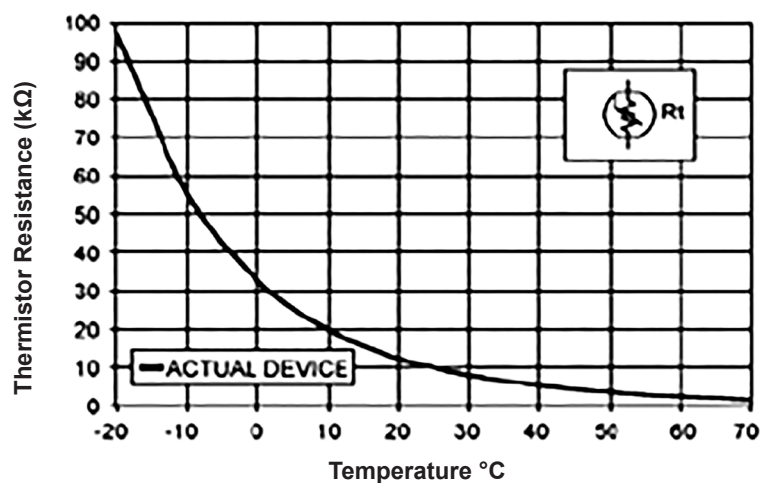

Figure 1.15

Following diagram shows physical appearance and relevant circuit symbol of the thermistor.

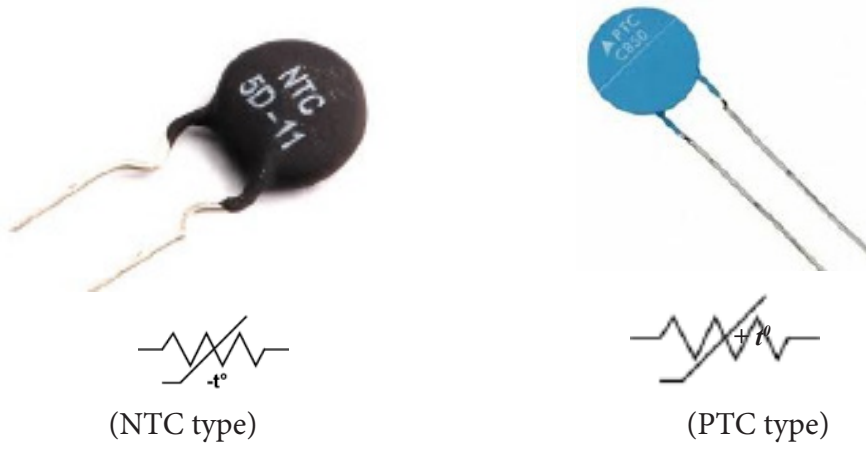

Figure 1.16

Chapter - 02

Thermal Expansion of Solids and Liquids

Expansion of Solids

In solids, molecules are subjected to undergo vibrations. Amplitudes of those vibrations increase as the temperature of the solid material increases. As a result, space occupied by the solid material increases. Therefore, its volume increases.

Increase of volume of a piece of material with rise of temperature is called thermal expansion.

Linear expansion

If we consider only the increase of length of an object with rise of temperature, then it is called linear expansion.

The amount of increase of length of an object is directly proportional to;

1. The original length (l_0)
2. The rise of temperature ($\Delta\theta$)

So,

$$\Delta l \propto l_0$$

$$\Delta l \propto \Delta\theta$$

$$\therefore \Delta l \propto l_0 \Delta\theta,$$

$$\therefore \Delta l = \alpha l_0 \Delta\theta, \text{ (where } \alpha \text{ is a constant)}$$

$$\therefore \alpha = \frac{\Delta l}{l_0 \Delta\theta},$$

This constant is known as the linear expansivity of the material of the object and is defined as the fractional increase of length per unit rise of temperature. The SI unit of α is K^{-1} .

Consider a thin rod of length l_1 at some temperature. When temperature is increased by the amount θ , suppose its new length is l_2 .



Figure 2.1

increase of length, $\Delta l = l_2 - l_1$

increase of temperature, $\Delta\theta = \theta_2 - \theta_1$

linear expansion, $\alpha = \frac{\Delta l}{l_1 \Delta\theta}$

$$\alpha = \frac{l_2 - l_1}{l_1 (\theta_2 - \theta_1)}$$

$$l_2 - l_1 = l_1 \alpha (\theta_2 - \theta_1)$$

$$= l_1 \alpha \theta \text{ here } \theta = \theta_2 - \theta_1$$

$$l_2 = l_1 + l_1 \alpha \theta$$

$$\boxed{l_2 = l_1 (1 + \alpha \theta)}$$

Area expansion

If we consider only the increase of area of an object due to temperature rise, then it is called area expansion.

The physical quantity (β) associated with the measurement of area expansion is known as superficial expansivity and is defined as the fractional increase of area per unit rise of temperature.

$$\therefore \beta = \frac{\Delta A}{A_0 \Delta\theta}$$

where, ΔA - increase in area

$\Delta\theta$ - rise of temperature

A_0 - initial area

The SI unit of β is K^{-1} .

Consider a surface area A_1 of an object at some temperature θ_1 . If the temperature is increased to θ_2 and its new surface area is A_2 .

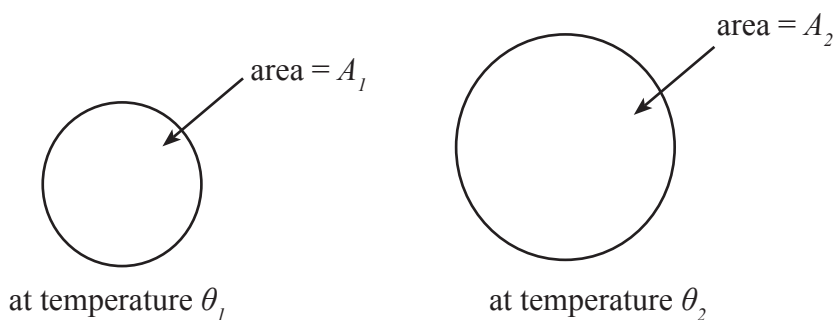

Figure 2.2

Increase of area $\Delta A = A_2 - A_1$, increase of temperature, $\Delta\theta_2 = \theta_2 - \theta_1$

By definition of β ,

$$\begin{aligned}\beta &= \frac{\Delta A}{A_0 \Delta\theta} \\ &= \frac{A_2 - A_1}{A_1 \theta} \quad \text{where } \theta = \theta_2 - \theta_1 \text{ (increase of temperature)}\end{aligned}$$

$$\therefore A_2 - A_1 = A_1 \beta \theta$$

$$\boxed{\therefore A_2 = A_1(1 + \beta\theta)} \dots\dots\dots(1)$$

Relationship between β and α

Consider a thin rectangular sheet of length a and breadth b at some temperature θ_1 . Suppose its temperature is increased to θ_2 and its new length and breadth are a' and b' respectively.

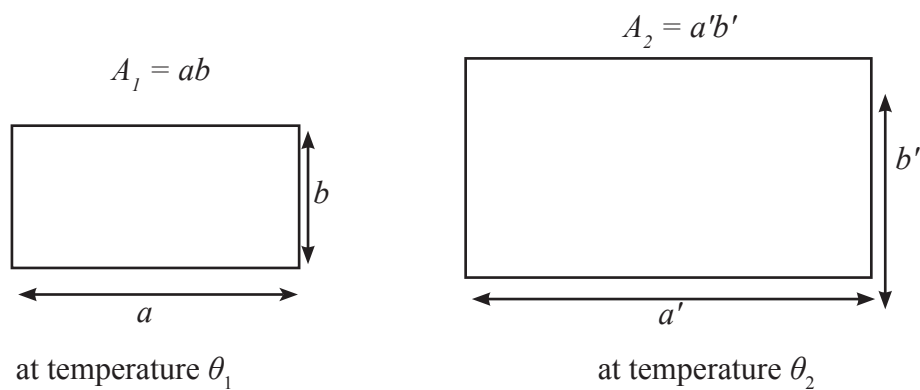

Figure 2.3

Considering linear expansion,

$$l_2 = l_1(1 + \alpha\theta) \quad \text{where } \theta = \theta_2 - \theta_1 \text{ (increase of temperature)}$$

$$\therefore a' = a(1 + \alpha\theta) \quad \text{where } \alpha \text{ is the linear expansivity of the material of the sheet}$$

$$b' = b(1 + \alpha\theta)$$

$$\therefore A_2 = a'b'$$

$$= ab(1 + \alpha\theta)^2$$

$$\Delta A = A_2 - A_1 = ab(1 + \alpha\theta)^2 - ab$$

$$= ab(1 + 2\alpha\theta + \alpha^2\theta^2) - ab$$

$$= ab(2\alpha\theta + \alpha^2\theta^2)$$

Since α is a small decimal value α^2 is much smaller. Therefore the term having α^2 can be neglected.

$$\therefore \Delta A = ab.2\alpha \approx \theta$$

$$\begin{aligned} \text{Now, } \beta &= \frac{\Delta A}{A_0\theta} \\ &= \frac{ab.2\alpha.\theta}{ab.\theta} = 2\alpha \\ \therefore \boxed{\beta = 2\alpha} \end{aligned}$$

Then from equation (1)

$$\boxed{A_2 = A_1(1 + 2\alpha.\theta)}$$

Volume expansion

Earlier it was stated that an increase of area of a piece of material with rise of temperature is called area expansion. If only the volume expansion is considered, then the expansion is called volume expansion.

The physical quantity γ associated with measurement of volume expansion is known as volume expansivity and is defined as the fractional increase of volume per unit rise of temperature.

$$\gamma = \frac{\Delta V}{V.\Delta\theta} \quad \begin{array}{l} \text{where } \Delta V \text{ - increase of volume} \\ V \quad \text{- initial volume} \\ \Delta\theta \quad \text{- increase of temperature} \end{array}$$

The SI unit of γ is K^{-1} .

Consider a piece of material of volume V_1 at temperature θ_1 . Suppose its new volume is V_2 when it is heated to a temperature θ_2 . Then by definition of γ ,

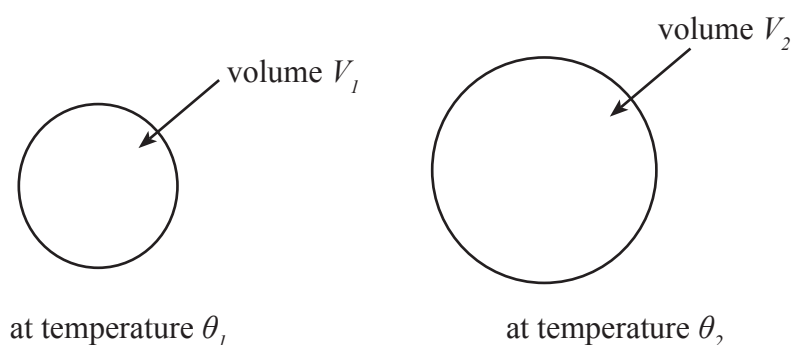

Figure 2.4

$$\gamma = \frac{\Delta V}{V_0 \cdot \Delta \theta} = \frac{V_2 - V_1}{V_1 \theta}$$

where $\theta = \theta_2 - \theta_1$ (increase of temperature)

$$\therefore V_2 - V_1 = V_1 \gamma \cdot \theta$$

$$\boxed{V_2 = V_1(1 + \gamma \cdot \theta)} \dots\dots\dots(2)$$

Relationship between γ and α

Consider a cuboid with length, breadth and height a , b and c respectively at temperature θ_1 and that their new values are a' , b' and c' respectively when its temperature is increased to θ_2 .

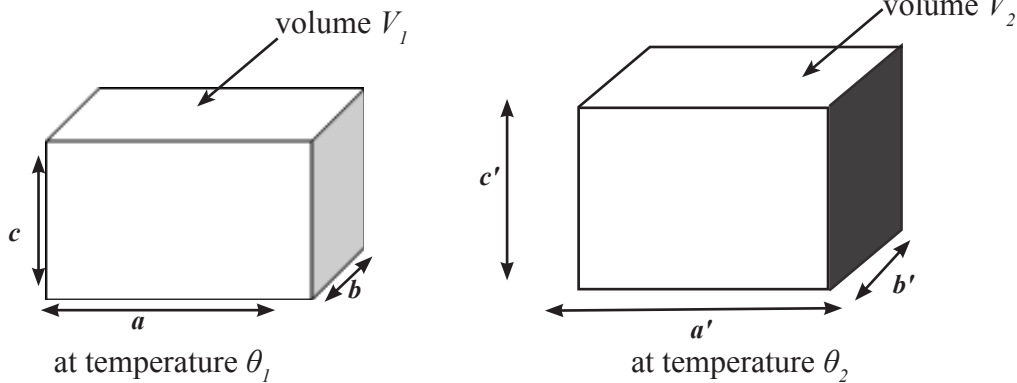

Figure 2.5

$$V_1 = abc$$

$$V_2 = a'b'c'$$

Considering linear expansion,

$$a' = a(1 + \alpha\theta) \quad b' = b(1 + \alpha\theta) \quad c' = c(1 + \alpha\theta)$$

$$V_2 = a' b' c'$$

$$V_2 = a (1 + \alpha\theta) \cdot b (1 + \alpha\theta) \cdot c (1 + \alpha\theta)$$

$$\therefore V_2 = abc(1 + \alpha\theta)^3$$

$$\therefore V_2 = abc(1 + 3\alpha\theta + 3\alpha^2\theta^2 + \alpha^3\theta^3)$$

$$\Delta V = V_2 - V_1$$

$$\begin{aligned} V_2 &= abc(1 + 3\alpha\theta + 3\alpha^2\theta^2 + \alpha^3\theta^3) - abc \\ &= abc(3\alpha\theta + 3\alpha^2\theta^2 + \alpha^3\theta^3) \end{aligned}$$

Since α is very small decimal value α^2 terms and α^3 terms are even smaller and can be neglected when compared with α .

$$\therefore V_2 = abc.3\alpha\theta$$

By definition of γ

$$\gamma = \frac{\Delta V}{V_0 \Delta \theta} = \frac{abc.3\alpha\theta}{abc\theta} = 3\alpha$$

$$\boxed{\therefore \gamma = 3\alpha}$$

Now the equation (2) above can be written as,

$$\boxed{V_2 = V_1(1 + 3\alpha\theta)}$$

Worked example

1. A sphere made of a metal has a radius 4 cm at 30 °C. What is the new radius, surface area and volume of the sphere when its temperature is raised to 130 °C? (linear expansivity of the metal is 0.0001 K⁻¹)

Considering linear expansion along a diameter,

$$l_2 = l_1(1 + \alpha.\theta)$$

$$l_2 = 8[1 + 0.0001 \times (130 - 30)]$$

$$= 8(1 + 0.01)$$

$$= 8.08 \text{ cm}$$

$$\therefore \text{New radius} = \frac{8.08}{2} = \underline{\underline{4.04 \text{ cm}}}$$

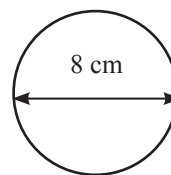

Considering area expansion,

$$A_2 = A_1 (1 + 2\alpha\theta)$$

$$= 4\pi.4^2(1 + 2 \times 0.0001 \times 100)$$

$$= 64\pi(1 + 0.02)$$

$$= 65.28 \text{ A}$$

$$= 65.28 \times 3.14$$

$$\therefore \text{new area} = \underline{\underline{205 \text{ cm}^2}}$$

Considering volume expansion,

$$\begin{aligned}
 V_2 &= V_1 (1 + 3 \pm \infty \theta) \\
 &= \frac{4}{3} \pi (4)^3 (1 + 3 \times 0.0001 \times 100) \\
 &= \frac{4}{3} \pi \cdot 64 (1 + 0.03) \\
 &= \frac{4}{3} \pi \times 64 \times 1.03 \\
 &= \frac{4}{3} \times 3.14 \times 64 \times 1.03 \\
 &= 275 \text{ cm}^3
 \end{aligned}$$

$$\therefore \text{new volume} = \underline{\underline{275 \text{ cm}^3}}$$

2. A thin sheet of metal has the shape of a square of side 0.1 m. A small square of side 0.02 m has been cut off from the sheet as shown in figure given below. When the temperature of the sheet and the cutting is increased by 150 °C, calculate the new lengths of the sheet and the cutting. (linear expansivity of the metal is 0.00002 K⁻¹)

$$\begin{aligned}
 l_2 &= l_1 (1 + \infty \theta) \\
 &= 0.1 (1 + 0.00002 \times 150) \\
 &= 0.1 (1 + 0.003) \\
 &= 0.1003 \text{ m}
 \end{aligned}$$

$$\therefore \text{new length of the sheet} = \underline{\underline{0.1003 \text{ m}}}$$

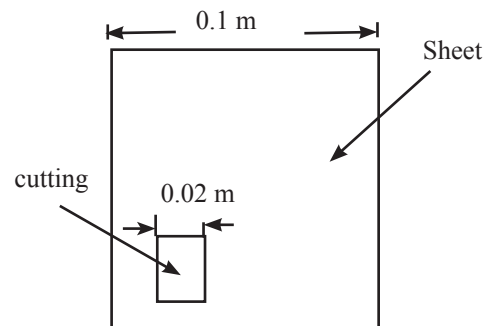

As the cutting also expands,

$$\begin{aligned}
 l_2 &= l_1 (1 + \infty \theta) \\
 &= 0.02 (1 + 0.00002 \times 150) \\
 &= 0.02 (1 + 0.003) \\
 &= 0.02006 \text{ m}
 \end{aligned}$$

$$\therefore \text{new length of the cutting} = \underline{\underline{0.02006 \text{ m}}}$$

Expansion of liquids

As a liquid is kept in a container, when the liquid is heated, the container also gets heated. Therefore, both the liquid and the container expand. As the shape of a fixed volume of a liquid can vary depending on the shape of the container, the only expansion taken into account when a liquid is concerned is the volume expansion.

If the material of the container is such that its volume expansion is much smaller than that of the liquid, then we can neglect the expansion of the container. Then we can consider only the observed expansion of the liquid when the container is heated. The observed expansion of the liquid, without taking expansion of the container into account is called the apparent expansion of the liquid. The amount by which the liquid actually expands is called the real expansion of the liquid. The apparent expansion is less than the real expansion.

Consider a liquid in a flask as shown in Figure 2.6. A thin tube is fixed to the flask using a rubber stopper as shown.

The liquid is filled up to the mark “a” on the tube.

When the flask is heated we can observe initially the liquid level in the tube goes down slightly and thereafter it starts going up. Initial falling of the liquid level is due to expansion of the flask and the final raising is due to the expansion of liquid.

Although both expansions take place at the same time, for the simplicity of understanding let us suppose that only the container expands first and the liquid expands afterwards as shown by Figure 2.7.

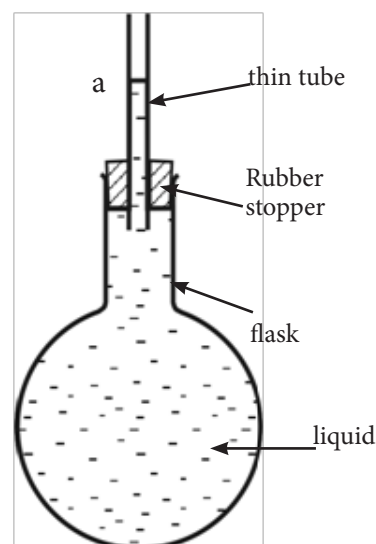

Figure 2.6

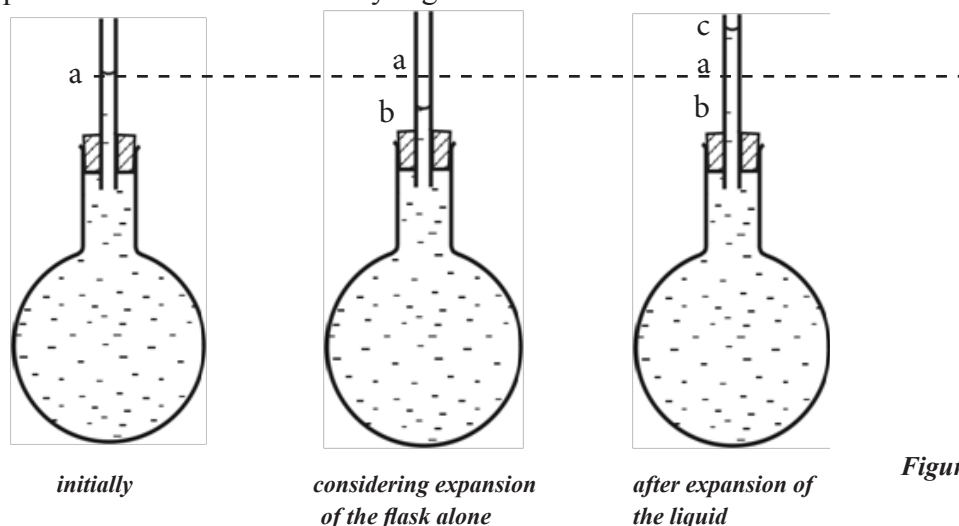

Figure 2.7

From the above diagrams,

It is clear that volume in between the levels;

a and b is equal to the expansion of flask alone

b and c is equal to the real expansion of liquid

a and c in equal to the apparent expansion of liquid

Then it is obvious that,

(Volume between b and c) = (Volume between a and c) + (Volume between a & b)

i.e.

real expansion (of a liquid) = apparent expansion (of the liquid) + expansion of the container

According to this, two expansivities can be considered based on real expansion and apparent expansion.

Real expansivity (γ_{real}) and apparent expansivity ($\gamma_{apparent}$) of a liquid can be defined as follows.

$$\gamma_{real} = \frac{\Delta V_{real}}{V_0 \Delta \theta}$$

$$\gamma_{apparent} = \frac{\Delta V_{apparent}}{V_0 \Delta \theta}$$

where ΔV_{real} is the real expansion

$\Delta V_{apparent}$ is the apparent expansion

V_0 is the initial volume

$\Delta \theta$ is the increase of temperature

By further calculation it can be shown that,

$$\gamma_{real} = \gamma_{apparent} + \gamma_{container}$$

and

$$\gamma_{real} = \gamma_{apparent} + \alpha \gamma_{container}$$

Where γ_{real} is the real expansivity of the liquid and $\alpha_{container}$ is the linear expansivity of the container material.

Eg. A Vessel contains a liquid of volume 0.0005 m^3 at 30°C . If the real (volume) expansivity of the liquid is 0.001 K^{-1} and the linear expansivity of the material of the vessel is 0.0001 K^{-1} , find the apparent increase and the real increase of volume of the liquid when the vessel is heated up to 100°C .

for the liquid,

$$\gamma_{real} = \frac{\Delta V_{real}}{V_o \Delta \theta}$$

$$\therefore 0.001 = \frac{\Delta V_{real}}{0.0005 \times 70}$$

$$\begin{aligned} \Delta V_{real} &= 0.001 \times 0.0005 \times 70 \\ &= 3.5 \times 10^{-5} \text{ m}^3 \end{aligned}$$

$$\therefore \text{real increase of liquid volume} = \underline{\underline{3.5 \times 10^{-5} \text{ m}^3}}$$

$$\begin{aligned} \text{from } \gamma_{real} &= \gamma_{apparent} + 3\alpha \\ 0.001 &= \gamma_{apparent} + 3 \times 0.0001 \\ \therefore \gamma_{apparent} &= 0.001 - 0.0003 \\ &= \underline{\underline{0.0007 \text{ K}^{-1}}} \end{aligned}$$

$$\text{Now Using } \gamma_{apparent} = \frac{\Delta V_{apparent}}{V_o \Delta \theta}$$

$$\begin{aligned} \therefore \Delta V_{apparent} &= 0.0007 \times 0.0005 \times 70 \\ &= \underline{\underline{2.45 \times 10^{-5}}} \end{aligned}$$

$$\therefore \text{apparent expansion of liquid volume} = \underline{\underline{2.45 \times 10^{-5} \text{ m}^3}}$$

Variation of density with temperature



Figure 2.8

Consider a volume V_1 of a fixed mass of liquid having density ρ_1 at temperature θ_1 . When the temperature of the liquid is increased to θ_2 , let new volume and density be V_2 and ρ_2 respectively.

Then, The mass of liquid at $\theta_1 \Rightarrow V_1\rho_1$

The mass of liquid at $\theta_2 \Rightarrow V_2\rho_2$

Since the mass is fixed,

$$V_1\rho_1 = V_2\rho_2 \dots\dots\dots(1)$$

Taking real expansivity of the liquid as γ

$$V_2 = V_1(1 + \gamma\theta)$$

where $\theta = \theta_2 - \theta_1$ (increase of temperature)

$$\therefore \text{from (1), } V_1\rho_1 = V_1(1 + \gamma\theta)\rho_2$$

$$\boxed{\rho_2 = \frac{\rho_1}{1 + \gamma\theta}}$$

So it is clear that the density of liquids decreases with increase of temperature. However unlike other liquids water is found to behave in a different manner within a particular range of temperature.

Anomalous expansion of water

Consider the following graph which shows the variation of volume (V) of a fixed mass of water with temperature (θ).

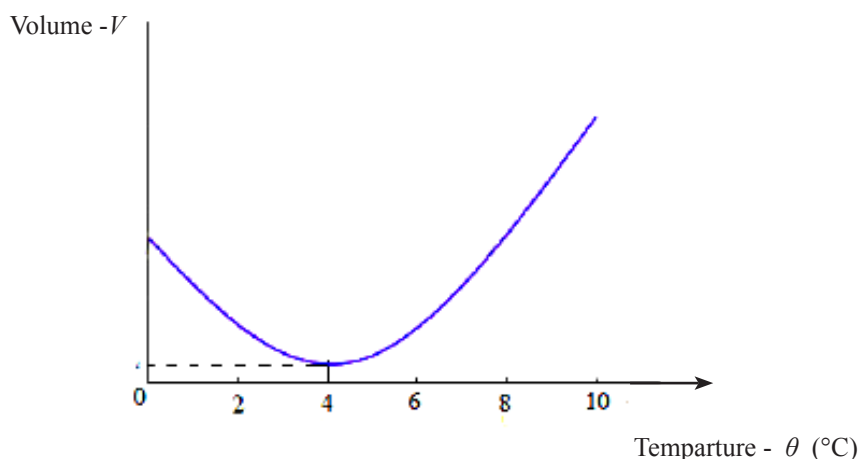

Figure 2.9

It is clear from the graph that the volume of water increases with rise of temperature only for temperatures greater than 4°C . In the temperature range 0°C to 4°C , the volume of water decreases with rise of temperature. Therefore, if temperature is decreasing from 4°C to 0°C , then the volume of water is increasing instead of decreasing. This is on contrary to normal behaviour of a liquid. Normal behaviour is to decrease volume with decrease of temperature. The expansion of water when temperature is going down from 4°C to 0°C is known as the anomalous expansion of water. Moreover, it is clear that for a fixed mass of water the minimum volume and hence the maximum density exist at 4°C and hence maximum density of water exists at 4°C .

Due to anomalous expansion, the density of water also varies accordingly with rise of temperature. The density of water increases from 0°C to 4°C instead of decreasing, and it begins to decrease with the rise of temperature beyond 4°C . This is shown in Figure 2.10.

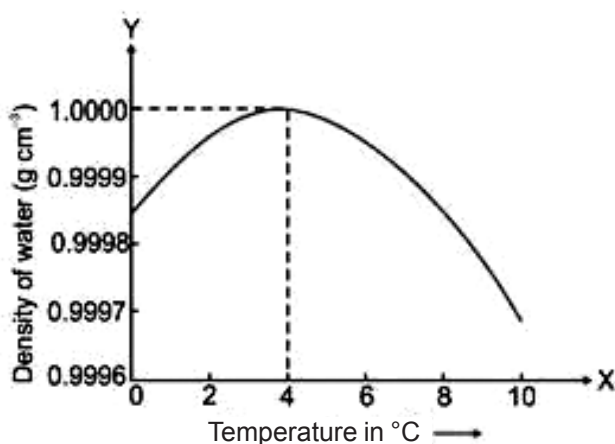

Figure 2.10

Chapter - 03

Gas Laws

In order to indicate the physical state of a given mass of a gas, its volume (V) pressure (p) and temperature (T) can be stated as parameters. Gas laws are built up using the relationships between V , p and T to explain the behaviour of a constant mass of a gas between two states.

Since the distance between two molecules of a gas is about 10 times the distance between two molecules of a liquid, the intermolecular attractive forces in a gas are as less as 1% of that in a liquid. Also in every gas the volume of its molecules is extremely smaller than the volume occupied by the gas. As an example, the volume of hydrogen molecules in a litre (1000 cm^3) of hydrogen gas is as small as 0.2 cm^3 . This is true for any gas. Hence it can be considered that the physical behaviour of different gases does not depend on the type of the gas molecules, and that all gases behave physically in a similar way.

Hence, for all gases, it can be assumed that,

1. The intermolecular attractive forces are negligibly small.
2. The volume of the gas molecules is negligibly small when compared with the volume of the gas.

A gas which behaves according to above assumptions is known as a perfect gas. Gases can be considered to behave as perfect gases under normal pressure and temperature conditions. There are three fundamental laws obeyed by perfect gases.

Boyle's Law

The pressure of a fixed mass of a gas is inversely proportional to its volume, provided the temperature remains constant.

$$p \propto \frac{1}{V}$$

$$p = k \frac{1}{V} \text{ or } pV = k$$

where k is a constant for the given mass and the temperature of the gas, the following graphs can be drawn considering the above conditions.

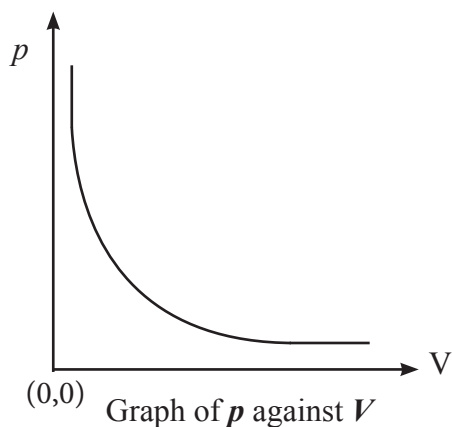

Figure 3.1

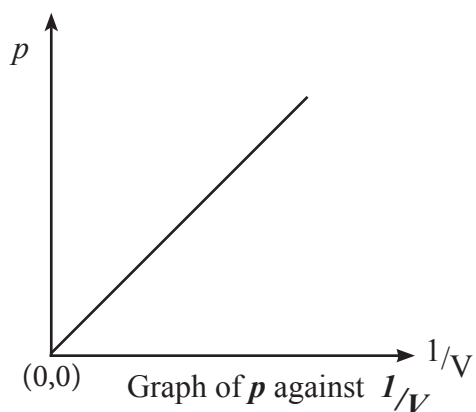

Figure 3.2

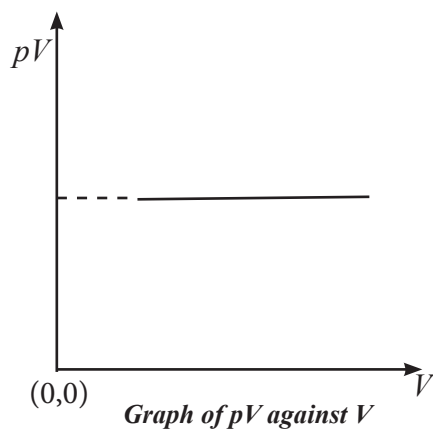

Figure 3.3

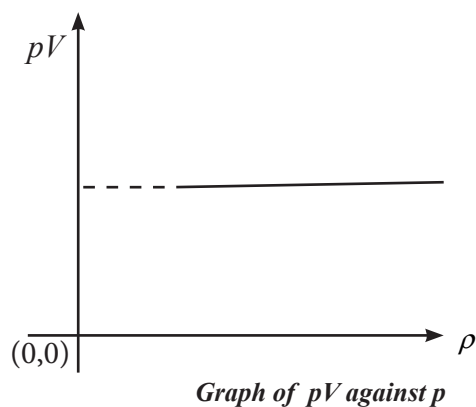

Figure 3.4

If p_1, V_1 and p_2, V_2 are the pressures and volumes respectively of a given mass of gas in two different states at a constant temperature, then

$$p_1V_1 = k \quad \text{and} \quad p_2V_2 = k$$

$$\therefore \boxed{p_1V_1 = p_2V_2}$$

Worked examples

- (1) The pressure of a fixed mass of a gas was reduced by 25% of its existing value, keeping the temperature constant. What would then be the percentage change in the volume of the gas?

The pressure, after reduction by 25%, $p_2 = p - \frac{25p}{100} = \frac{75p}{100} = \frac{3}{4}p$

If the volume changes to V_2 ,

$$p_1V_1 = p_2V_2$$

$$pV = \frac{3}{4}pV_2$$

$$V_2 = \frac{4}{3}V$$

Increase in volume $\Delta V = V_2 - V_1 = \frac{4}{3}V - V = \frac{V}{3}$

Percentage increase in volume $= \frac{\Delta V}{V} \times 100\%$

$$= \frac{V}{3V} \times 100 = \underline{\underline{33.33\%}}$$

- (2) In a defective barometer, a quantity of air has entered into the space above the mercury column in the tube. When the length of this air column is 250 mm the height of the mercury column in the Barometer above the outside level is 750 mm. When the length of the air column is reduced to 200 mm the height of the mercury column is 746 mm. Calculate the atmospheric pressure. Assume that the temperature remained constant.

Solution

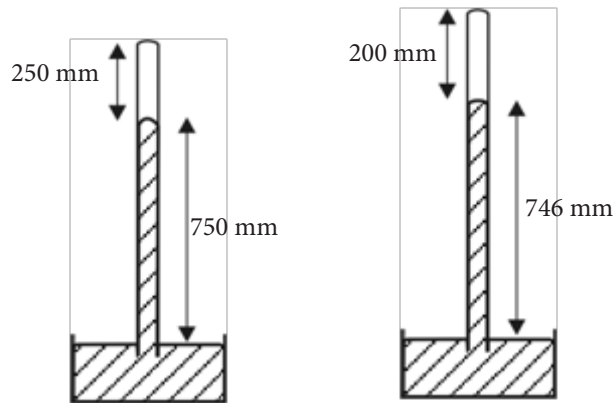

Figure 3.5

Let h (mm) be the atmospheric pressure.

If the area of cross-section of the tube is (A) mm^2 ,

In the first state, volume of the mass of gas $V_1 = (250 A)$ mm^3

Pressure of the mass of gas, $p_1 = (h - 750)$ mm Hg (where h is the atmospheric pressure in mm Hg)

In the second state,

Volume of the mass of gas, $V_2 = (200A)$ mm³

Pressure of the mass of gas $p_2 = (h - 750)$ mm Hg

Since the temperature is constant,

Applying Boyle's law,

$$\begin{aligned}
 p_1 V_1 &= p_2 V_2 \\
 (h - 750) \cdot 250A &= (h - 746) \cdot 200A \\
 5(h - 750) &= 4(h - 746) \\
 5h - 4h &= 3750 - 2984 \\
 h &= \underline{\underline{766 \text{ mm Hg}}}
 \end{aligned}$$

Charles' Law

The volume of a fixed mass of a gas is directly proportional to its absolute temperature, provided the pressure remains constant.

$$V \propto T$$

$$V = kT$$

where k is a constant for the given mass of gas under constant and its pressure

$$\frac{V}{T} = k$$

For two states of a given mass of a gas at constant pressure,

$$\frac{V_1}{T_1} = k \text{ and } \frac{V_2}{T_2} = k$$

$$\therefore \boxed{\frac{V_1}{T_1} = \frac{V_2}{T_2}}$$

Worked example

At 27 °C the volume of a given mass of perfect gas is 1000 cm³. If its temperature is raised to 227 °C at constant pressure. What will be the new volume of the gas?

Solution

$$\frac{V_1}{T_1} = \frac{V_2}{T_2}$$

$$\frac{1000}{(127 + 273)} = \frac{V_2}{(227 + 273)}$$

$$\frac{1000}{400} = \frac{V_2}{500}$$

$$V_2 = \frac{1000 \times 500}{400} = 1250$$

$$\therefore \text{new volume of gas} = \underline{\underline{1250 \text{ cm}^3}}$$

The pressures law

The pressure of a fixed mass of a gas is directly proportional to its absolute temperature provided the volume remains constant.

$$p \propto T$$

$$p = kT$$

Where k is a constant for the given mass of the gas under constant pressure.

$$\frac{p}{T} = k$$

For two states of a given mass of a gas at constant volume,

$$\frac{p_1}{T_1} = k \text{ and } \frac{p_2}{T_2} = k$$

$$\therefore \boxed{\frac{p_1}{T_1} = \frac{p_2}{T_2}}$$

Solved example

A closed bulb contains air at a temperature of 27 °C under a pressure of 80 mm Hg. What will be the pressure of air inside the bulb if the temperature of the bulb is raised to 100 °C ? Neglect the expansion of the bulb.

According to the law of pressures,

$$\frac{p_1}{T_1} = \frac{p_2}{T_2} \text{ at constant volume}$$

$$\frac{80}{27 + 273} = \frac{p_2}{100 + 273}$$

$$p_2 = \frac{80 \times 373}{300}$$

$$p_2 = 99.5$$

$$\therefore \text{the pressure of air at } 100 \text{ }^\circ\text{C} = \underline{\underline{99.5 \text{ mm Hg}}}$$

For a further study of gas laws, an attention to the following would be beneficial.

Avagadro's hypothesis

Equal volumes of all gases at the same temperature and pressure contain the same number of molecules.

Mole

A mole is the amount of a substance containing the number of atoms equal to that contained in 0.012 kg of the carbon - 12 isotope.

Avagadro number (N_A)

The Avagadro number is the number of molecules contained in one mole of a gas.

$$N_A = 6.02 \times 10^{23} \text{ mol}^{-1}$$

At standard temperature (0°C) and normal pressure (760 mm Hg), the volume of a mole of any gas is 22.4 litres.

Molar mass

The mass of one mole of a gas is the molar mass of the gas.

Equation of state of a gas

It has been mentioned earlier that p , V and T are the three parameters which indicate the physical state of a given mass of a gas.

By means of the gas laws discussed so far, it has been explained how these parameters two at a time, vary from one state to another. The next step will be to study the variation of all three parameters from one state to another.

For this purpose consider a fixed mass of a gas enclosed in a vessel using a movable frictionless piston. Let the initial values of the volume, pressure and absolute temperature be V_1 , p_1 and T_1 respectively.

Let the pressure be first changed to a new value p_2 with the temperature kept constant at T_1 . As a result of which the volume changes to V' .

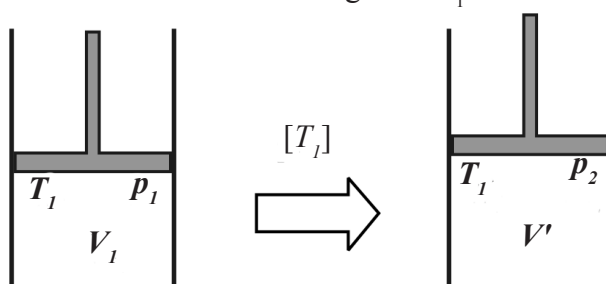

Figure 3.6

Applying Boyle's law for this change at constant temperature,

$$p_1 V_1 = p_2 V' \quad V' = \frac{p_1 V_1}{p_2} \dots\dots\dots 4.3.1$$

Next keeping the pressure constant, let the temperature changes to T_2 . As a result of which the volume changes again to a new value V_2 .

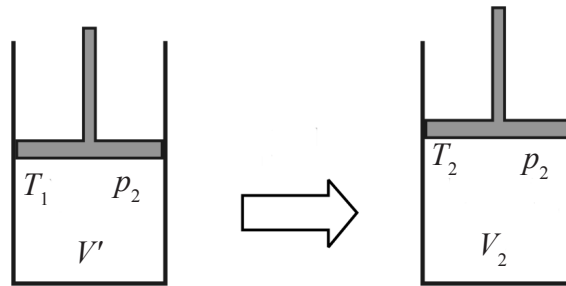

Figure 3.7

Applying Charles law for the change at a constant pressure,

$$\frac{V'}{T_1} = \frac{V_2}{T_2}$$

$$\therefore V' = \frac{T_1 V_2}{T_2} \dots\dots\dots 4.3.2$$

From equations 4.3.1 and 4.3.2

$$\frac{p_1 V_1}{p_2} = \frac{T_1 V_2}{T_2}$$

$$\therefore \boxed{\frac{p_1 V_1}{p_2} = \frac{p_1 V_2}{T_2}}$$

Hence for a given mass of a gas constant. This relationship is known as the equation of state of a gas.

Worked Example

A certain mass of an enclosed gas $\frac{pV}{T} = a$ occupies a volume of under a pressure of 20 kPa at a temperature of 27 °C. If the temperature of the gas is raised to 42 °C and the volume is compressed to 200 l, to which value should its pressure be changed?

Applying $\frac{p_1 V_1}{T_1} = \frac{p_2 V_2}{T_2}$ to the mass of the gas,

$$\frac{20 \times 400}{300} = \frac{p_2 \times 200}{315}$$

$$p_2 = \frac{20 \times 400 \times 315}{300 \times 200}$$

$$p_2 = \underline{\underline{42 \text{ kPa}}}$$

∴ New pressure = 42 kPa

Note: In the above substitution each quantity should have identical units on both sides.

Ideal gas equation

In the equation of state of a gas, $\frac{pV}{T}$ is a constant.

If the mass of the gas is selected to contain one mole of gas then the above constant is known as the universal gas constant 'R'. Hence, for one mole of the gas

$$\frac{pV}{T} = R$$

If the mass of the gas concerned contains 'n' moles of gas then,

$$\frac{pV}{T} = nR$$

$$\therefore \boxed{pV = nRT}$$

The above equation is the "Ideal gas equation". By considering the fact that at standard temperature and pressure, one mole of a gas occupies a volume of 22.4 litres, the value of R can be calculated and shown that, $R = 8.31 \text{ J mol}^{-1} \text{ K}^{-1}$.

number of moles, $n = 1$

standard temperature, $T = 273 \text{ K}$

standard pressure, $p = 760 \text{ mmHg}$

$$= (760 \times 10^{-3}) \times (13.6 \times 10^3) \times (9.8) \text{ Pa}$$

$$V = 22.4 \text{ l} = 22.4 \times 10^{-2} \text{ m}^3$$

$$R = \frac{pV}{nT} = \frac{760 \times 10^{-3} \times 13.6 \times 10^3 \times 9.8 \times 22.4 \times 10}{1 \times 273}$$

$$= 8.31$$

$$\therefore R = 8.31 \text{ J mol}^{-1} \text{ K}^{-1}$$

Also, if the mass of the gas concerned is 'm' and its molar mass is 'M',

$$\text{Then, } n = \frac{m}{M}$$

$$\therefore pV = \frac{m}{M} RT$$

$$p = \frac{m}{v} \frac{RT}{M}$$

$$\boxed{p = \rho \frac{RT}{M}}$$

where ρ is the density of the gas at the given temperature T and pressure p .

Worked Example

- 1) A vessel of volume 3l and with an opening to the atmosphere, is filled with a gas containing 'n' moles at 31 °C. In order to remove $\frac{1}{5}$ th of the number of these moles from the vessel, upto what temperature should the vessel be heated, assuming that the gas remains under atmospheric pressure.

From , $pV = nRT$,

$$nT = \frac{pV}{R} = \text{constant (V is constant at 3l and p is constant at atmospheric pressure)}$$

$$\therefore n_1 T_1 = n_2 T_2$$

$$n \times 304 = \left(n - \frac{n}{5} \right) T_2$$

$$n \times 304 = \frac{4n}{5} \cdot T_2$$

$$T_2 = 380 \text{ K}$$

\therefore The temperature to which the vessel should be heated = 380 K

- (2) A mass of 19 kg of a gas under a pressure of 9.5 times the atmospheric pressure is stored in a cylinder at a temperature of 70 °C. When the cylinder is brought to an environment at 27 °C, a safety valve in the cylinder is opened to release a certain portion of the gas to the atmosphere. The escape of the gas takes place only when the pressure of the gas in the cylinder exceeds 10 times the atmospheric pressure. Calculate mass of the gas released.

Solution

Let V be the volume of the cylinder and A be the atmospheric pressure. If n_1 is the number of gas moles inside the cylinder initially, for the initial stage

$$pV = nRT$$

$$9.5AV = n_1RT$$

$$n_1 = \frac{9.5AV}{280 \cdot R}$$

n_2 is the number of gas moles in the cylinder for the final stage,

$$pV = nRT$$

$$10AV = n_2R(300)$$

$$n_2 = \frac{10AV}{300 \cdot R}$$

If m is the mass of the gas remaining in the cylinder finally, then since the mass of the gas is directly proportional to the number of moles,

$$\frac{m}{19} = \frac{n_2}{n_1}$$

$$\frac{m}{19} = \frac{10 \times 280}{9.5 \times 300}$$

$$m = 18.67 \text{ kg}$$

$$\therefore \text{Mass of gas emitted to the atmosphere} = (19 - 18.67) \text{ kg} = 0.33 \text{ kg}$$

Dalton's law of partial pressures

This law is used to find the total pressure of a mixture of gases occupying a certain volume at a given temperature. It is stated as follows.

“If a mixture of gases which do not react with each other is in a closed volume, the total pressure exerted by the mixture is equal to the sum of partial pressures exerted by each gas or vapour in the mixture.”

The partial pressure of a gas in a mixture is the pressure exerted by that gas alone when it occupies the whole volume of the mixture at constant temperature.

Dalton’s law of partial pressures can be explained as follows.

Consider a closed volume V of a mass of gas consisting of 3 constituents indicated as +, o and •

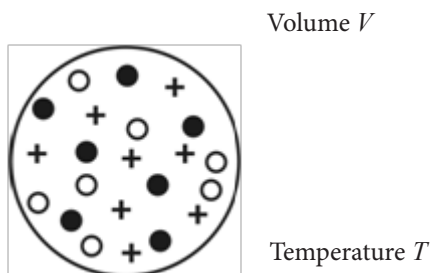

Figure 3.8

Then the partial pressure due to the constituent + can be illustrated by the following diagrams.

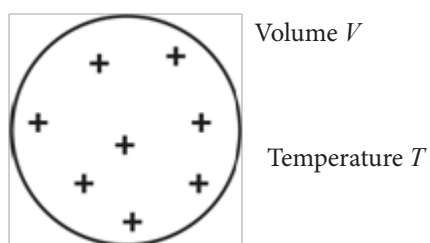

Figure 3.9

Similarly, Dalton’s law of partial pressures can be explained by the following illustration. If the three constituents are named as A, B and C then the law can be written as,

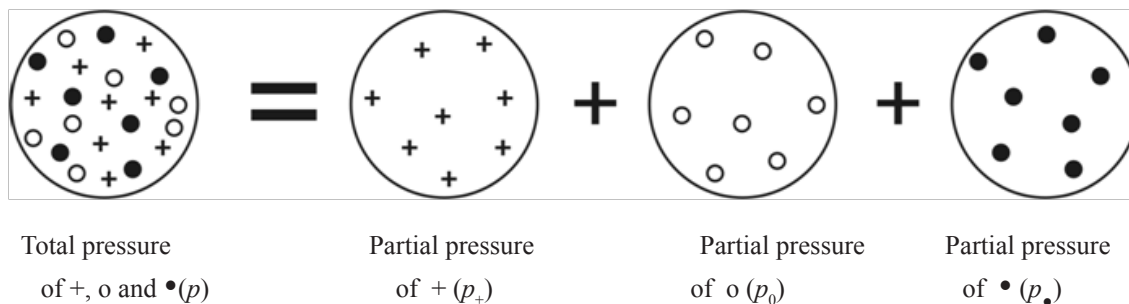

Figure 3.10

$$p = p_A + p_B + p_C$$

where,

p = total pressure of the mixture

p_A = partial pressure of the constituent A

p_B = partial pressure of the constituent B

p_C = partial pressure of the constituent C

The mean square speed ($\overline{c^2}$) obtained by squaring the individual speed of each gas molecule and then calculating the mean of these squared speeds. The square root of it, $\sqrt{\overline{c^2}}$ is called the mean square speed.

Chapter - 04

Kinetic Theory of Gases

In the kinetic molecular theory of gases, a relationship between the pressure and the volume of a gas is built up using the microscopic properties of gas molecules.

The following assumptions are made in developing this theory.

- (1) Gas molecules behave as perfectly elastic spheres.
- (2) The volume of the gas molecules is negligible in comparison with the volume of the vessel containing the gas.
- (3) The intermolecular attractive forces between the molecules are negligibly small.
- (4) The time of collision of a molecule with the wall of the container is negligibly small when compared with time between two collisions of molecules.

In this theory, the following expression has been derived by considering the force due to the change of momentum resulted by the collisions of molecules with the walls of the container.

$$pV = \frac{1}{3}mN\overline{c^2}$$

where

p = pressure of the gas

V = Volume of the gas

m = mass of a gas molecule

N = total number of gas molecules in the gas volume

$\overline{c^2}$ = mean square velocity of molecules

Kinetic theory of gases was first forwarded by the scientist James Clark Maxwell in 1860.

Mean square speed ($\overline{c^2}$)

At any temperature, the speeds of the molecules of a gas are not equal to each other. This is due to the changes that occur in velocity during their collisions.

The mean square speed ($\overline{c^2}$) is obtained by squaring the individual speed of each gas molecule and then calculating the mean of these squared speeds. The square root of $\overline{c^2}$, $\sqrt{\overline{c^2}}$ is called the root mean square speed.

Relation between the density of a gas and its root mean square speed

The total mass of the gas is Nm .

$$\text{Hence density } \rho = \frac{Nm}{V}$$

$$\text{According to } pV = \frac{1}{3}mN\overline{c^2}$$

$$p = \frac{1}{3} \frac{mN}{V} \overline{c^2}$$

$$p = \frac{1}{3} \rho \overline{c^2}$$

$$\therefore \boxed{\overline{c^2} = \frac{3p}{\rho}}$$

Worked Example

At a given temperature, a balloon is filled with hydrogen gas of density 0.09 kg m^{-3} under a pressure of 10^5 Pa . What is the root mean square velocity of hydrogen molecules at this temperature?

$$\text{Using } \overline{c^2} = \frac{3p}{\rho}$$

$$\sqrt{\overline{c^2}} = \sqrt{\frac{3 \times 10^5}{0.09}} = \underline{\underline{1.8 \times 10^3 \text{ m s}^{-1}}}$$

The relation between the temperature and the root mean square speed

$$\text{Considering equations } pV = \frac{1}{3}mN\overline{c^2} \quad \text{and} \quad pV = nRT,$$

$$\frac{1}{3}mN\overline{c^2} = nRT$$

Since Nm is the mass of the gas

$$\text{No of gas moles} = n = \frac{Nm}{M} \quad \text{where } M \text{ is the molar mass of the gas.}$$

$$\therefore \frac{1}{3}mN\overline{c^2} = \frac{Nm}{M}RT$$

$$\therefore \frac{1}{3}M\overline{c^2} = RT$$

$$\overline{c^2} = \frac{3RT}{M}$$

$$\boxed{\sqrt{\overline{c^2}} = \sqrt{\frac{3RT}{M}}}$$

Hence, when M is constant, r.m.s speed depends on T
and when T is constant, r.m.s. speed depends on M .

The relation between mean kinetic energy and the temperature of gas molecules

considering $pV = nRT$ and $pV = \frac{1}{3}mN\overline{c^2}$ equations.

$$\frac{1}{3}mN\overline{c^2} = nRT$$

$$\frac{1}{2}mN\overline{c^2} = \frac{3}{2}nRT$$

$$\frac{1}{2}m\overline{c^2} = \frac{3}{2} \frac{nRT}{N}$$

$$\frac{1}{2}m\overline{c^2} = \frac{3}{2} \frac{RT}{N_A}$$

$$\text{K}^{-1} \quad \frac{1}{2}m\overline{c^2} = \frac{3}{2}kT \quad \text{where } k \text{ is Boltzman constant } k = 1.38 \times 10^{-23} \text{ J K}^{-1}$$

Distribution of molecular speeds of a gas

It has been revealed by experimental data that in a given temperature, the speeds of the molecules of a gas are different from each other while most of the molecules gather around a certain speed. This result is illustrated by the graph given below.

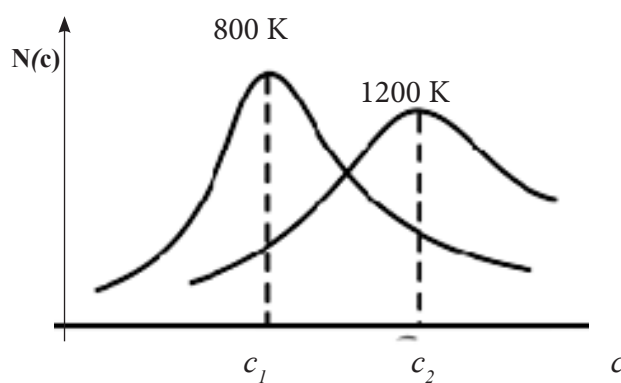

Figure 4.1

In this graph, c denotes the molecular speed and $N(c)$ is the number of molecules having that speed.

At 800 K, c_1 is the speed of most of the molecules and at 1200 K, c_2 is the speed of most of the molecules. It is clear that when the temperature increases, the most probable speeds of gas molecules too increase and hence the mean speed and the root mean square speed of the gas molecules also increase.

Worked example

At a temperature of 300 K and pressure of 2×10^5 Pa, the volume of a certain mass of helium gas is 0.04 m^3 . Calculate the following. (Relative molecular masses of helium and hydrogen are 4 and 2 respectively. Molar gas constant is $8.3 \text{ J mol}^{-1} \text{ K}^{-1}$)

- (i) Mass of helium gas
- (ii) Root mean square speed of helium gas molecules
- (iii) When the temperature of this gas is raised to 432 K under constant pressure, the root mean square velocity of its molecules
- (iv) Root mean square velocity of hydrogen molecules at 432 K

Solution

- (i) Let n be the number of helium gas moles.
according to $V = nRT$

$$n = \frac{pV}{RT} = \frac{2 \times 10^5 \times 0.04}{8.31 \times 300} = 3.2$$

$$\text{Mass of Helium gas} = 3.2 \times 4 = \underline{\underline{12.8 \text{ g}}}$$

- (ii) Density of helium gas $= \frac{\text{mass}}{\text{volume}} = \frac{12.8 \times 10^{-3}}{0.04} = 0.32 \text{ kg m}^{-3}$

$$\therefore \text{r.m.s. speed of helium} = \sqrt{\frac{3p}{\rho}} = \sqrt{\frac{3 \times 2 \times 10^5}{0.32}} = \underline{\underline{1369 \text{ m s}^{-1}}}$$

- (iii) Since r.m.s. speed $\propto \sqrt{T}$, if c_{He} is the r.m.s. velocity of helium gas molecules at 432 K,

$$\frac{c_{\text{He}}}{1369} = \sqrt{\frac{432}{300}} = \sqrt{1.44} = 1.2$$

$$\therefore c_{\text{He}} = 1.2 \times 1369 = \underline{\underline{1643 \text{ m s}^{-1}}}$$

- (iv) Since, at a given temperature, r.m.s. speed $\propto \frac{1}{\sqrt{M}}$

If c_H is the r.m.s. speed of hydrogen gas molecules at 432 K,

$$\frac{c_H}{c_{\text{He}}} = \sqrt{\frac{M_{\text{He}}}{M_H}} = \sqrt{\frac{4}{2}} = \sqrt{2}$$

$$\frac{c_H}{\sqrt{1643}} = \sqrt{2}$$

$$\therefore c_H = \sqrt{2} \times \sqrt{1643} = \underline{\underline{2324 \text{ m s}^{-1}}}$$

Chapter - 05

Exchange of Heat

Heat and transfer of energy

If a hot material is in contact with a cold one, the hot one cools down and loses internal energy, while the cold one heats up and gains internal energy. The energy transferred is known as heat. Thus, heat is the energy transferred from a body at a higher temperature to one at a lower temperature.

According to kinetic theory, atoms in a solid are vibrating to and fro about their equilibrium positions. Due to these vibrations, the solid has an internal energy. The hotter the material is, the faster its atoms move, and the more its internal energy is. Hot objects have higher temperatures. Thus the temperature of a body can be used in measuring the internal energy of a body.

Heat capacity of a body (C)

The amount of heat that has to be given to a body in order to increase the temperature of it by one unit is defined as the heat capacity.

If the temperature of a body rises by (θ), when an amount Q of heat is given to the body;

The amount of heat needed to increase the temperature by one unit = $\frac{Q}{\theta} = C$

$$\therefore C = \frac{Q}{\theta}$$

The SI unit of heat capacity is J K^{-1} . Above equation is used as follows to find the amount of heat that a body gains or loses.

$$Q = C\theta$$

Worked example

The heat capacity of a copper container is 320 J K^{-1} . Find the amount of heat that should be supplied to increase the temperature of the container by 40°C .

$$C = 320 \text{ J K}^{-1} \quad \theta = 40^\circ\text{C} = 40 \text{ K (Difference of } 1^\circ\text{C} = \text{difference of } 1 \text{ K)}$$

$$Q = C\theta = 320 \times 40 = 12800 \text{ J} = \underline{\underline{12.8 \text{ kJ}}}$$

Specific heat capacity of a substance (c)

The amount of heat required to raise the temperature of a unit mass of a substance by 1 unit of temperature (1°C or 1 K) defined as the specific heat capacity of that substance.

If amount Q of heat is required to raise the temperature by amount θ of a body of mass m ;

Amount of heat required to raise the temperature by θ of the mass $m = Q$

Amount of heat required to raise the temperature by θ of the mass $1\text{ kg} = \frac{Q}{\theta}$

Amount of heat required to raise the temperature by 1°C (1 K) of the mass $1\text{ kg} = \frac{Q}{m\theta} = c$

Units of specific heat capacity is $\text{J kg}^{-1}\text{ K}^{-1}$ (or $\text{J kg}^{-1}\text{ }^{\circ}\text{C}^{-1}$)

Following equation can be used to calculate the amount of heat transferred from or to a body.

$$\boxed{Q = mc\theta}$$

Relationship between heat capacity and specific heat capacity

If the heat capacity of a body is C and the heat needed to raise the temperature of the body by θ is Q , then

$$Q = C\theta$$

If the specific heat capacity of the substance is c and the mass of the body is m

$$Q = mc\theta$$

From above two equations,

$$\boxed{C = mc}$$

Worked Example

100 g of water at 20°C is in a copper calorimeter of mass 50 g. Find the amount of heat required to increase the temperature to 60°C .

specific heat capacity of copper = $390\text{ J kg}^{-1}\text{ K}^{-1}$

specific heat capacity of water = $4200\text{ J kg}^{-1}\text{ K}^{-1}$

Amount of heat required

$$\begin{aligned} Q &= (m_{Cu}c_{Cu} + m_w c_w)(\theta_2 - \theta_1) \\ &= \left(\frac{50}{1000} \times 390 + \frac{100}{1000} \times 4200 \right) (60 - 20) = (19.5 + 420) \times 40 = \underline{\underline{17,580\text{ J}}} \end{aligned}$$

Heat exchange

When a hot object is in contact thermally with another cold object, heat flows from the hot object to the cold object and finally the temperature of both objects comes to the same value.

According to the principle of heat exchange;

If the heat loss to the environment is negligible

$$\boxed{\text{Heat removed from the hot object} = \text{Heat acquired by the cold object}}$$

Worked example

Find the final temperature when an iron piece of mass 50 g heated to 100 °C is put into 100 g of water 20 °C in a container of heat capacity 420 J K⁻¹.

Specific heat capacity of iron = 120 J kg⁻¹ K⁻¹

Specific heat capacity of water = 4200 J kg⁻¹ K⁻¹

Temperature of water at the beginning = 20 °C

If the heat loss to the environment is negligible;

Heat removed from the piece of iron = Heat acquired by water + Heat acquired by the container

$$\begin{aligned} \frac{50}{1000} \times 120 \times (100 - \theta) &= \left(\frac{100}{1000} \times 4200 + 420 \right) (\theta - 20) \\ 6 \times (100 - \theta) &= (420 + 420) (\theta - 20) \\ 600 - 6\theta &= 840\theta - 840 \times 20 \\ 600 + 16800 &= 846\theta \\ \theta &= \frac{17400}{846} = \underline{\underline{20.57 \text{ } ^\circ\text{C}}} \end{aligned}$$

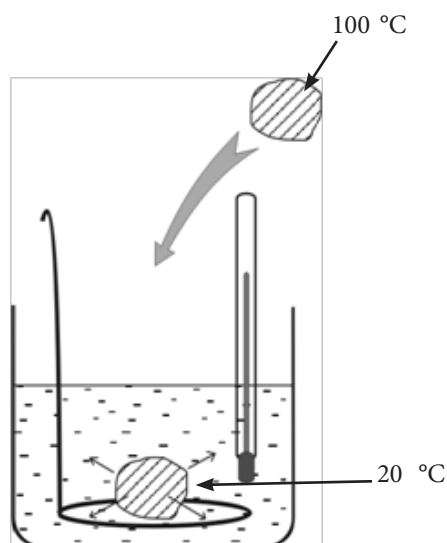

Molar heat capacities of a gas

A change in temperature of a gas involves a change in pressure and volume. Keeping any one of those pressure and volume constant, one at a time, two molar heat capacities for a gas can be defined.

1. The molar heat capacity of a gas at constant pressure (C_p). This is defined as the amount of heat required to produce unit temperature rise in one mole of the gas when the pressure remains constant.
2. The molar heat capacity of a gas at constant volume (C_v). This is defined as the amount of heat required to produce unit temperature rise in one mole of the gas when the volume remains constant.

When a gas is heated at constant pressure it expands and some of the heat supplied to the gas is used to do external work. Therefore not all the heat supplied is used to increase the temperature. But, when a gas is heated at constant volume all the heat supplied to it is used to increase the temperature. It follows that the amount of heat required to rise the temperature of a gas at constant pressure is greater than that required to rise its temperature by the same amount at constant volume. Therefore in particular C_p is greater than C_v .

For a gas the ratio C_p/C_v , which is denoted by γ , depends on the atomicity of the gas. This is because there is a rotational kinetic energy in addition to the translational kinetic energy, when a molecule contains more than one atom. Following table shows relevant values depending on the atomicity of the gas.

atomicity	γ
monoatomic	1.67
diatomic	1.40
polyatomic	1.33

The specific heat capacity of water is $4200 \text{ J kg}^{-1} \text{ }^\circ\text{C}^{-1}$ (or $4200 \text{ J kg}^{-1} \text{ K}^{-1}$). This means that it requires 4200 J of heat to increase the temperature of 1 kg of water by 1°C (1 K).

Newton's law of cooling

The rate of loss of heat of a body, when it is cooling under conditions of forced convection, is directly proportional to the difference in temperature between the body and its surroundings.

$$\frac{dQ}{dt} \propto (\theta - \theta_R) \quad \text{where} \quad \frac{dQ}{dt} = \text{rate of loss of heat}$$

θ = temperature of the body

θ_R = temperature of the surroundings

The rate of heat loss of the body depends on the amount of surrounding areas of it and the nature of that area as well as, therefore,

$$\frac{dQ}{dt} \propto (\theta - \theta_R)$$

$$\frac{dQ}{dt} = kA(\theta - \theta_R)$$

where A is the surface area of the body of the body and k is a constant which depends on the nature of the surface area.

This law can be taken to be a good approximation for cooling under conditions of natural convection (eg: a body cooling in still air) provided that excess temperature is not greater than 30°C.

Using

$$\frac{dQ}{dt} = mc \frac{d\theta}{dt} \quad \text{-----(ii) (m and c are constants for a given object)}$$

from equation (i) and (ii) above

$$kA(\theta - \theta_R) = mc \frac{d\theta}{dt}$$

$$\therefore \frac{d\theta}{dt} = \frac{kA}{mc} (\theta - \theta_R) = K(\theta - \theta_R)$$

where $\frac{kA}{mc} = K$ which depends on A , m , c and k (k depends on the nature of the surface)

Chapter - 06

Changes of state

Substances can be in the states of solid, liquid or gas. In addition, it can change the state (eg. from solid to liquid or liquid to gas) at a specific temperature. These state changes can happen to the reverse direction also. These transformations are called “changes of state”.
e.g.:- Conversion of ice to water and water to steam

Fusion

Conversion of a solid to its liquid is called “fusion”. The constant temperature at which occurs is called the “melting point” of the solid.

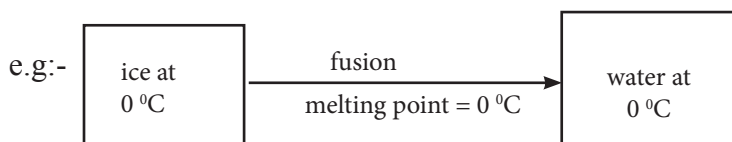

- Thermal energy is absorbed by the solid for this process during the whole period in which this transformation occurs. Even though the thermal energy is absorbed there is no increase in temperature. Therefore, this energy is called “latent heat”.
- The thermal energy absorbed while a solid is converted to a liquid is called “the latent heat of fusion”.

**Vapourization (Boiling)**

Conversion of a liquid to its vapour is called “vaporization”, while the constant temperature at which it occurs is called its “boiling point”.

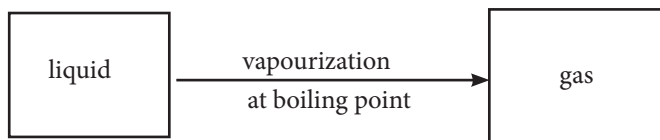

Thermal energy is absorbed by the liquid for this process also while the temperature is not changed. Therefore, this energy is also considered as a latent heat and it is called “the latent heat of vapourization”.

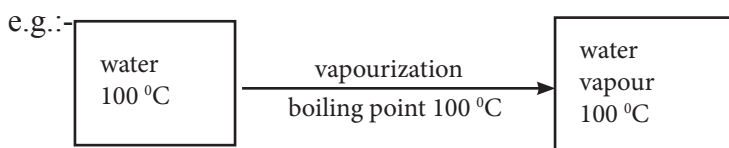

Specific latent heat of fusion of a solid (l)

Specific latent heat of fusion of a solid material is defined as the heat required to change the state of a unit mass of a solid to liquid without change of temperature (at its melting point).

If the amount of heat required to convert mass m of solid at boiling point to liquid at boiling point is Q ;

$$\text{specific latent heat of vapourization} = \frac{Q}{m} = l$$

$$\therefore \boxed{Q = ml}$$

Unit of specific latent heat of fusion is J kg^{-1} .

E.g.:-

Specific latent heat of fusion of ice (l) = $3.36 \times 10^5 \text{ J kg}^{-1}$. This conveys that it needs $3.36 \times 10^5 \text{ J}$ of energy to convert 1kg of ice at 0°C .

Specific latent heat of vapourization of a liquid (L)

Specific latent heat of vapourization of a liquid is defined as the heat required to change the state of a unit mass of a liquid to its vapour without change of temperature (at its boiling point).

If the amount of heat required to convert mass m of solid at boiling point to liquid at the boiling point is Q :

$$\text{specific latent heat of vapourization} = \frac{Q}{m} = L$$

$$\therefore \boxed{Q = mL}$$

Unit of specific latent heat of vaporization is J kg^{-1} .

Specific latent heat of vapourization of water (L) is $2.24 \times 10^6 \text{ J kg}^{-1}$. This implies that it needs 2.24×10^6 of energy to convert 1 kg of water at 100°C to vapour at 100°C .

Worked example

- 01) Calculate the amount of heat required to convert 100 g of ice at 0°C to vapour at 100°C .
 Specific latent heat of fusion of ice = $3.36 \times 10^5 \text{ J kg}^{-1}$
 Specific latent heat of vapourization of water = $2.24 \times 10^6 \text{ J kg}^{-1}$
 Specific heat capacity of water = $4200 \text{ J kg}^{-1} \text{ K}^{-1}$

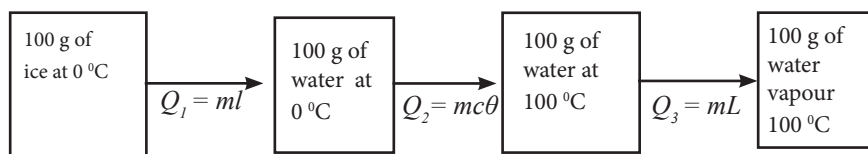

$$\begin{aligned}
 \text{Amount of heat required} &= 0.1 \times 3.36 \times 10^5 + 0.1 \times 4200 \times 100 + 0.1 \times 2.24 \times 10^6 \\
 &= 3.36 \times 10^4 + 4.2 \times 10^4 + 22.4 \times 10^4 \\
 &= 29.96 \times 10^4 \\
 &= \underline{\underline{3.0 \times 10^5 \text{ J}}}
 \end{aligned}$$

02) Find the final temperature of the system, if 40 g of ice at 0 °C is added to a calorimeter 100 g of water at 20 °C. Neglect the heat exchange with the surroundings.

Heat capacity of the calorimeter = 320 J K⁻¹

Specific latent heat of fusion of ice = 3.36 × 10⁵ J kg⁻¹

Specific heat capacity of water = 4200 J kg⁻¹ K⁻¹

Since the heat exchange with the surroundings is negligible,

Heat supplied by the container + Heat supplied by water = Heat acquired by ice

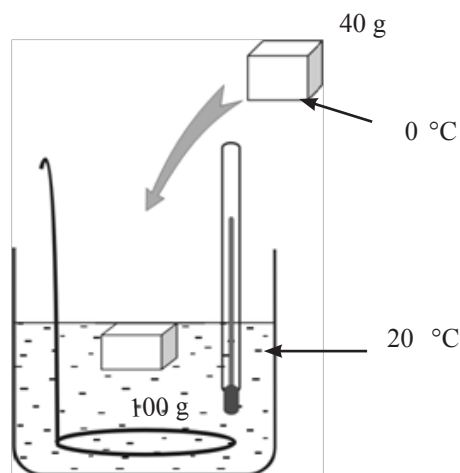

Figure 6.1

First it should be checked whether the water reaches 0 °C when the whole ice is melted at 0 °C.

heat given by "calorimeter + when reaching 0°C,

$$Q_1 = (320 + \frac{100}{1000} \times 4200)(20-0) = 14800 \text{ J}$$

heat required to melt ice at 0 °C, $Q_2 = \frac{40}{1000} \times 3.36 \times 10^5 = 13440 \text{ J}$

As $Q_2 < Q_1$, the water does not go down to 0°C

$$\left(320 + \frac{100}{1000} \times 420\right)(20 - \theta) = \frac{40}{1000} \times 3.36 \times 10^5 + \frac{40}{1000} \times 4200 \times (\theta - 0)$$

$$740(20 - \theta) = 40 \times 336 + 168 \times \theta$$

$$\theta = \frac{1360}{908} = \underline{\underline{1.5^\circ\text{C}}}$$

Latent heat

Consider a case in which a solid is converted to a liquid.

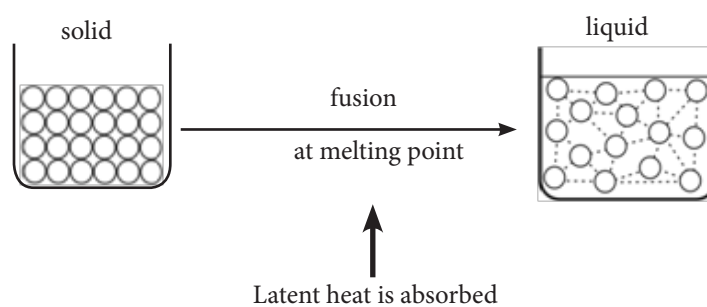

Figure 6.2

The molecules are closely packed in the solid and when it converts to a liquid the attractive forces among molecules are weakened to make the molecules drift apart. Most of the latent heat is consumed in this process. An additional work is done in increasing the volume.

Latent heat of vapourization can also be explained in a similar way.

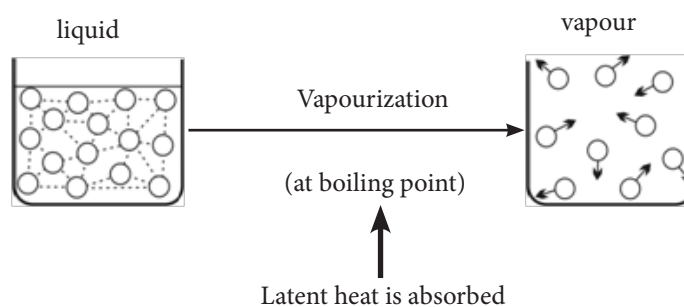

Figure 6.3

In vapourization heat is absorbed to destroy the bonds between molecules. In addition, heat is used to do work in increasing the volume. Consider a case where heat is supplied to a solid at a constant rate. Then the time readings and the relevant temperature readings are recorded. Using those readings, the graph of temperature (θ) Vs. time (t) is given in Figure 6.5.

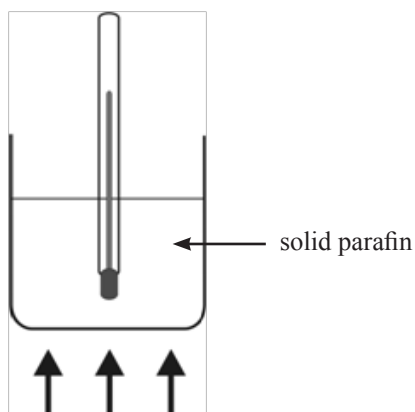

Figure 6.4

Graph of temperature vs. time

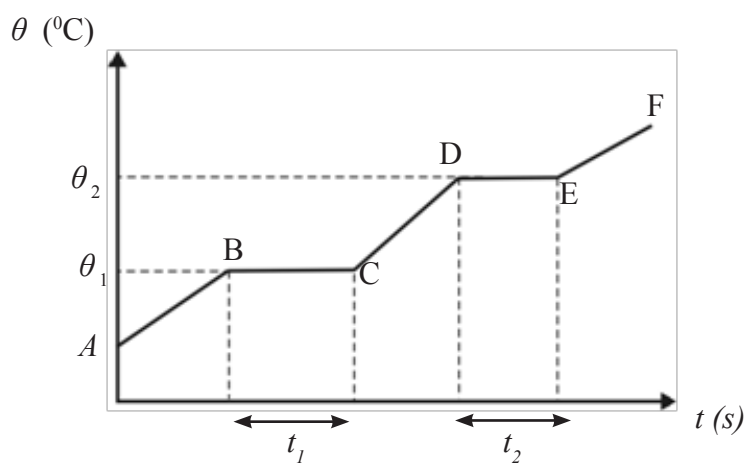

Figure 6.5

- θ_1 - melting point
- θ_2 - boiling point
- AB - heating up as a solid
- BC - state change (fusion)
- CD - heating up as a liquid
- DE - state change (vapourization)
- EF - heating up as a vapour

A \longrightarrow B, Rate of heat absorption $\longrightarrow \left(\frac{Q}{t}\right) = mc_{solid} \left(\frac{\theta}{t}\right)_{AB}$ \swarrow Gradient of AB

B \longrightarrow C, Rate of heat absorption $\longrightarrow \left(\frac{Q}{t}\right) = \frac{ml}{t_1}$

C \longrightarrow D, Rate of heat absorption $\longrightarrow \left(\frac{Q}{t}\right) = mc_{liquid} \left(\frac{\theta}{t}\right)_{CD}$ \swarrow Gradient of CD

D \longrightarrow E, Rate of heat absorption $\longrightarrow \left(\frac{Q}{t}\right) = \frac{mL}{t_2}$

From the above four equations

$$mc_{solid} \left(\frac{\theta}{t}\right)_{AB} = \frac{ml}{t_1}$$

$$mc_{liquid} \left(\frac{\theta}{t}\right)_{CD} = \frac{mL}{t_2}$$

l and L can be found using above two equations.

Chapter - 07

Vapour and Humidity

Vapour

In any liquid, those molecules possessing high energy are in the process of leaving the liquid zone through its surface. This phenomenon is called evaporation. This evaporation process can take place at any temperature and can be explained as follows using the molecular structure of a liquid.

When molecules of a liquid are considered, they are in random motion and the kinetic energy of these molecules increase with the supply of thermal energy. Molecules on the surface of a liquid are bound to the liquid. Molecules in the liquid having high energy on reaching the surface escape from it to form vapour.

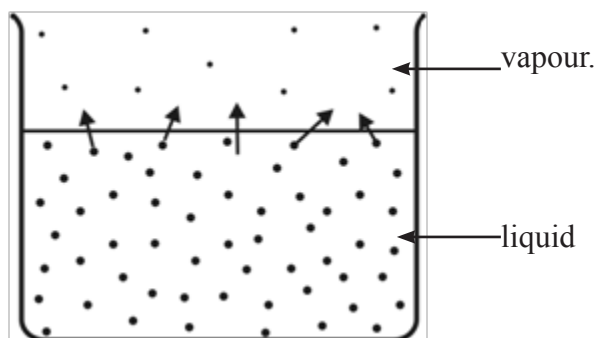

Figure 7.1

Saturated vapours and unsaturated vapours

Consider a vapour in contact with its liquid. As shown above, since those molecules having high energy evaporate into the vapour zone, the amount of vapour in the vapour zone increases. As the amount of vapour in the vapour zone increases at a given temperature, the returning of molecules in the vapour zone back to the liquid zone can also occur. At some instance these two processes reach an equilibrium in which the vapour contains the maximum amount of vapour molecules it can possess at that temperature. Such a vapour in equilibrium with its liquid known as “saturated vapour”.

If the amount of liquid vapour present in a given volume at some temperature, is less than the maximum amount of liquid vapour it can possess at that temperature, then that vapour is called unsaturated vapour.

The number of unsaturated vapour molecules in a closed volume in contact with its liquid, remains a constant (ie. the mass of vapour is constant even when the temperature changes) and hence unsaturated vapour obeys gas laws. But the number of saturated vapour molecules does not remain constant when the temperature changes (ie. the mass of vapours is not constant). Therefore, saturated vapour does not obey gas laws.

The following activities show that gases in general as well as vapours exert pressure. For this purpose, consider a barometer consisting of a glass tube about 100 cm long inserted vertically in a vessel filled with mercury. When a liquid is inserted into the tube from below as shown in Figure 7.2, it can be seen that when the liquid reaches the vacuum zone above the mercury, it evaporates and the mercury level in the tube goes down from its initial level.

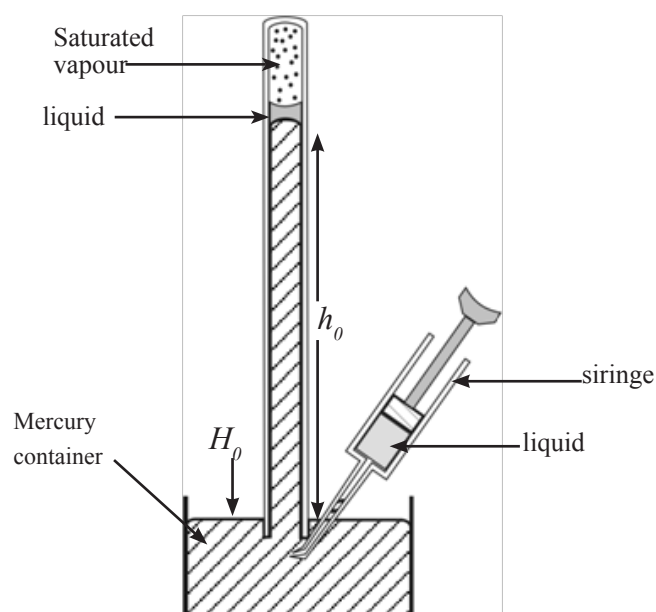

Figure 7.2

Observe the diagram above from which it becomes clear that the vapour exerts a pressure. As seen here, as long as the liquid remains on the mercury surface without getting evaporated the mercury level (h_0) remains unchanged without falling. Thus it can be concluded that pressure of a saturated vapour takes a constant value at a given temperature and is referred to as “saturated vapour pressure” (p_0) at the given temperature.

The set of apparatus shown by the diagram in the next page can be used to investigate practically the relationship between the vapour pressure and the volume of vapour at constant temperature.

Initially the mercury surface in the tube B is brought close to the tap T which is then open and a small quantity of a liquid is introduced into it. The tap is then closed not

allowing air to occupy the space above the liquid. When the mercury level in the tube B is now lowered (keeping some liquid remains on the mercury surface) saturated vapour is formed in the closed space above the liquid.

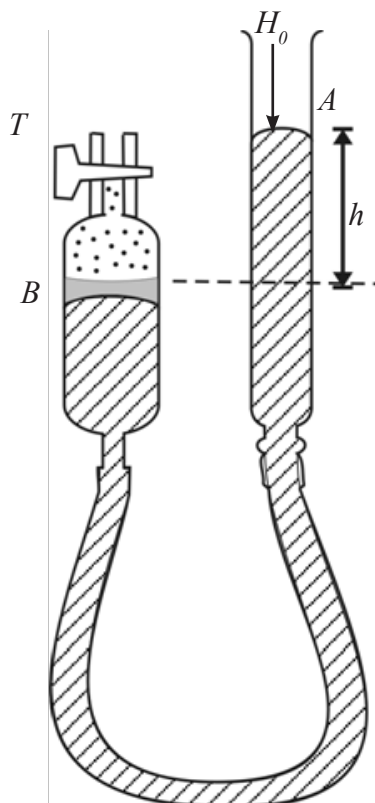

Figure 7.3

If h is the difference between the mercury levels in tubes A and B , p_0 is the saturated vapour pressure of the liquid in tube B .

$$p_0 = H_0 + h \rho g$$

Where H_0 is the atmospheric pressure. As long as the liquid exists in the tube B , and the temperature remains constant, it can be observed that the difference in the mercury levels remains constant irrespective of the volume of vapour in B is. This observation confirms that the saturated vapour pressure remains constant at constant temperature.

When the liquid on the mercury surface in tube B completely evaporates, the vapour in the tube B becomes unsaturated. The variation of pressure of an unsaturated vapour with its volume is the same as the general behavior of a gas. The variation of pressure of a saturated vapour as well as an unsaturated vapour at a constant temperature is illustrated by the graph in Figure 7.4 (a).

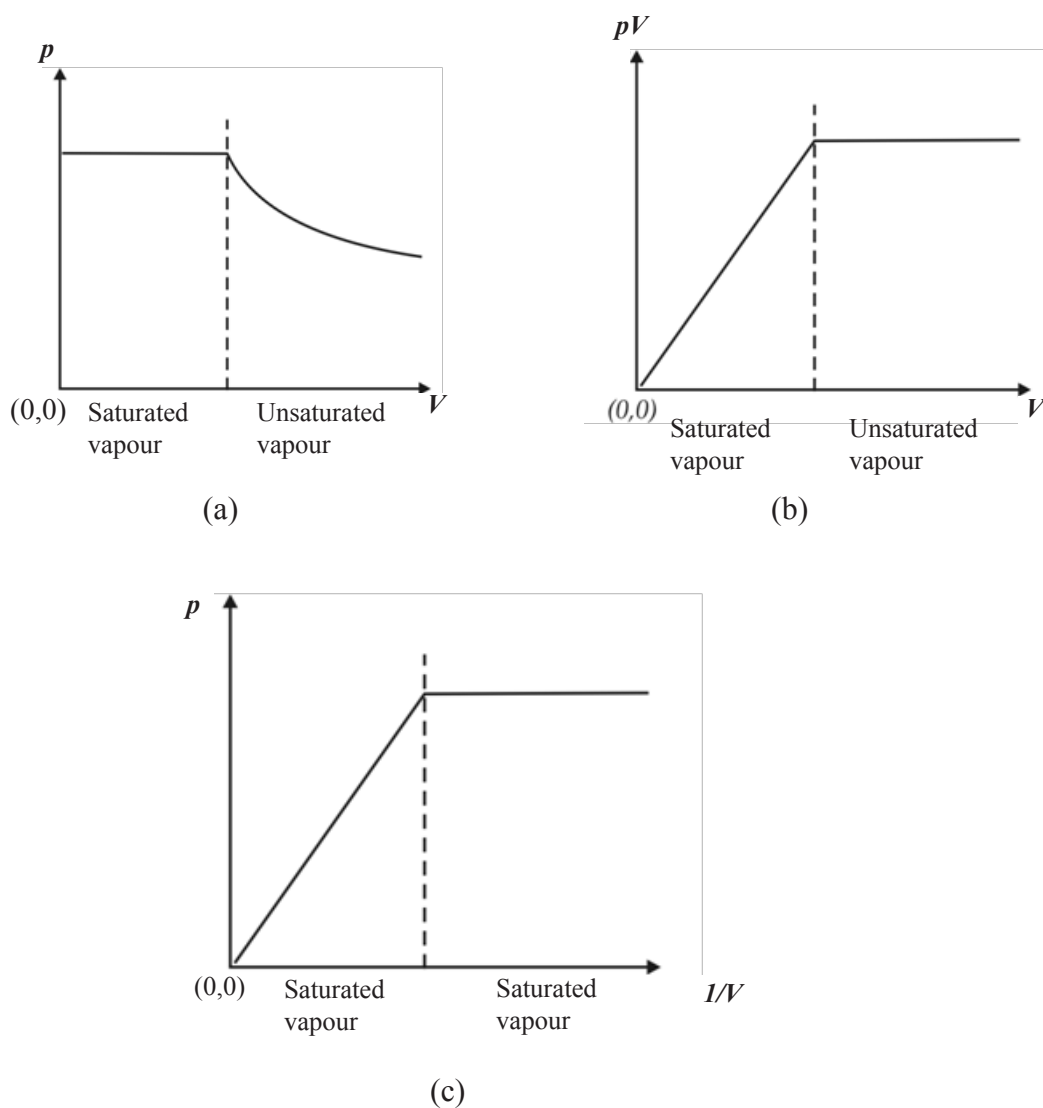

Figure 7.4

All these graphs (a), (b) and (c) indicate that unsaturated vapour obeys gas laws while saturated vapour deviates from gas laws. The reason for this is that in a saturated vapour, the number of vapour molecules in contact with the liquid does not remain a constant when the volume changes.

The set-up shown in Figure 7.4 (a) can be used to study the variation of saturated vapour pressure with temperature.

The temperature of saturated vapour can be varied by varying the temperature of hot water flowing around the barometer tube and the pressure of saturated vapour can be measured using the barometer. When this pressure (P_a) is plotted against temperature (θ) it gives the graph shown in Figure 7.6.

Generally, the pressure of a gas at constant volume increases with temperature due to increase of kinetic energy of molecules and thereby increasing the number of bombardment of molecules on the walls of the container.

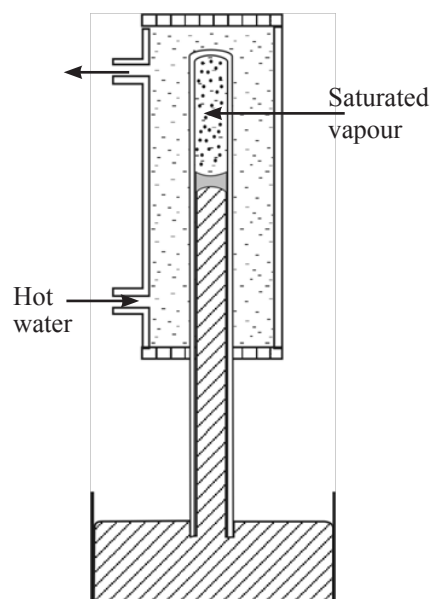

Figure 7.5

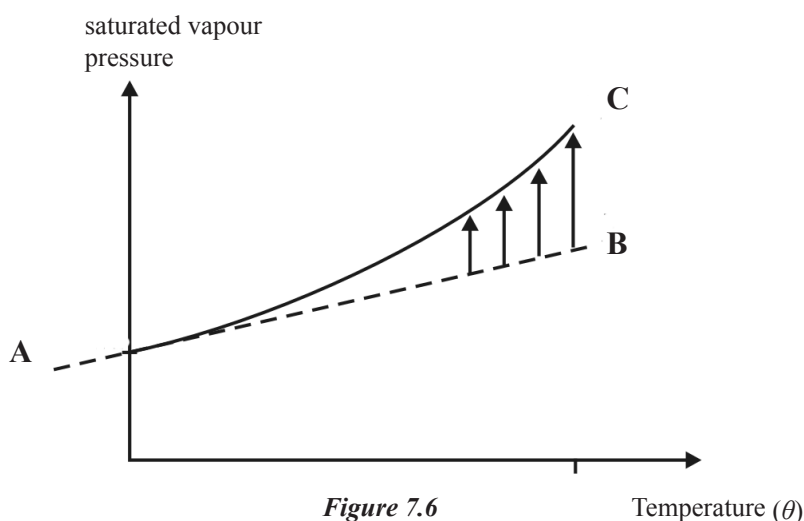

Figure 7.6

But in case of a saturated vapour, the number of vapour molecules increases with temperature and therefore increases pressure at a rate greater than the rate of increase of pressure of a gas (AB). Hence it can be seen that the pressure (p_0) of a saturated vapour increases at a higher rate with temperature.

Ex.:- A closed vessel initially contains a little amount of water and with the increase of temperature of the vessel ultimately all the water evaporates indicate by means of a graph, the variation of vapour pressure with temperature.

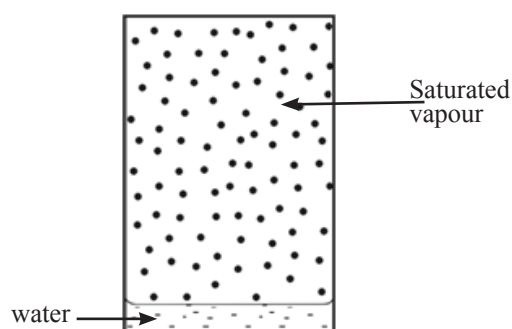

Figure 7.7

Initially, since the vapour in the vessel is saturated (because the vapour is in contact with water), the pressure increases faster with increase of temperature. But when all the water evaporates at a certain temperature (θ_0), the vapour becomes unsaturated and begins to behave as a gas obeying Charles' law. This is shown by the graph in Figure 7.8.

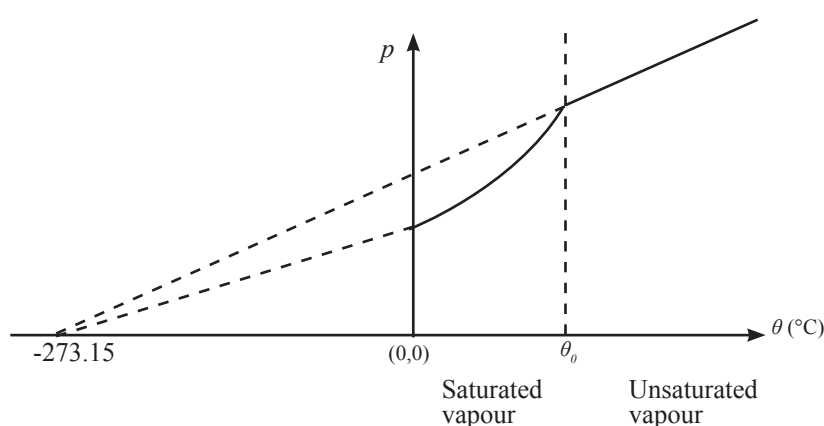

Figure 7.8

Evaporation and vapourization (boiling)

The evaporation process of a liquid has been described earlier. There is a special temperature where the entire liquid volume starts transference into vapour state. This is known as vapourization (boiling) of a liquid and the temperature at which this occurs is called the boiling point. The table 7.1 shows the differences between vapourization and evaporation.

Table 7.1 Comparison of Evaporation and Vapourization

Evaporation	Vapourization
A process that can occur at various temperatures	Occurs only at a constant temperature (boiling point of a liquid)
Takes place only on liquid surfaces	Takes place within the whole liquid volume
Depends on the amount of vapour existing above the liquid	Does not depend on the liquid vapour existing above the liquid

Hygrometry

The amount of water vapour existing in the environment is an important factor in day-to-day activities. It affects environmental conditions such as growth of trees and health of people.

The energy released from the human body during metabolism (chemical processes occur within living organisms) leaves the body along with the water vapour. This process is referred to as “perspiring” in general. When the amount of water vapour present in the environment is less the sweat produced by perspiration, leaves the body easily. Various methods are used to provide comfort to human body by controlling the amount of water vapour in the environment. The use of electric fans and air conditioning machines are some of them.

Two measurements used to find the amount of water vapour existing in the environment are considered now. They are known as absolute humidity (AH) and relative humidity (RH).

Absolute Humidity (AH)

Absolute humidity is defined as the mass of water vapour present in a unit volume of air in the environment. Assume that m is the mass of unsaturated vapour present in a closed volume V in the environment.

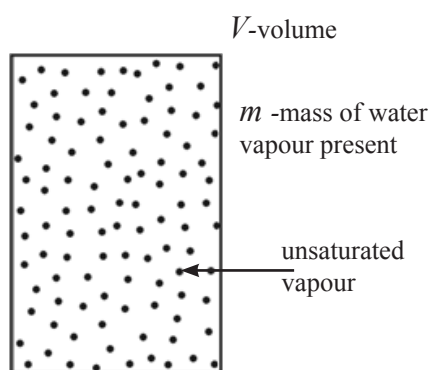

Figure 7.9

In Figure 7.9, mass of water vapour present in a volume $V = m$
Hence the absolute humidity, which is the mass of water vapour present in the unit volume is given as,

$$AH = \frac{m}{V}$$

The unit of absolute humidity is kg m^{-3} , therefore it can be considered as a measurement of vapour density.

Worked example

The absolute humidity of air in a closed hall of volume 500 m^3 is 20 g m^{-3} . Find the mass of water vapour present in the hall. If an air conditioning machine is to be used to remove a certain amount of water vapour in the hall in order to reduce the absolute humidity to 16 g m^{-3} , find the mass of water vapour to be removed.

$$\begin{aligned} \text{Mass of water vapour present in a unit volume of air} &= 20 \text{ g} \\ \therefore \text{Mass of water vapour present in } 500 \text{ m}^3 \text{ of air} &= \frac{20}{1000} \times 500 \text{ kg} \\ &= \underline{\underline{10 \text{ kg}}} \end{aligned}$$

$$\begin{aligned} \text{Mass of water vapour to be present in the room after} &= \frac{16}{1000} \times 500 \text{ kg} \\ \text{air conditioning} &= 8 \text{ kg} \\ \therefore \text{Mass of water vapour to be removed} &= (10-8) \text{ kg} = \underline{\underline{2 \text{ kg}}} \end{aligned}$$

Relative humidity (R_H)

The water vapour present in the atmosphere is usually unsaturated and in order to express its deviation from saturated vapour, the quantity called relative humidity (RH) is used.

The relative humidity of a given volume of air at some temperature is defined as the ratio of the mass (m) of water vapour present in that volume to the mass (m_0) of water vapour present in the same volume at the same temperature when it is saturated with water vapour.

By considering the volume V in Figure 7.10, the relative humidity can be obtained as follows.

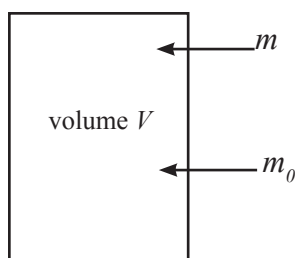

Figure 7.10

m – mass of water vapour present
 m_0 – mass of water vapour when saturated

$$\text{Relative humidity (RH)} = \frac{m}{m_0}$$

Since $m \leq m_0$ all the time $\frac{m}{m_0} \leq 1$

In practice, RH is expressed as a percentage.

$$\boxed{RH = \frac{m}{m_0} \times 100\%}$$

Worked Example :-

The mass of water vapour present in a given volume of air is 400 g. If this volume of air becomes saturated when 120 g of water vapour is admitted into it, find its initial relative humidity.

$$\begin{aligned}
 \text{The mass of water vapour present in the given volume of air} &= 400 \text{ g} \\
 \text{The mass of water vapour present when the same volume is saturated} &= (400 + 120) \text{ g} \\
 &= 520 \text{ g} \\
 \therefore \text{Relative humidity of the volume (RH)} &= \frac{400}{520} \times 100 \\
 &= \underline{\underline{76.9\%}}
 \end{aligned}$$

Other expressions for relative humidity

According to definition of relative humidity,

$$RH = \frac{m}{m_0} \times 100\%$$

By considering a volume V , relative humidity can be written as,

$$RH = \frac{\frac{m}{V}}{\frac{m_0}{V}} \times 100\% \quad \therefore \boxed{RH = \frac{\rho}{\rho_0} \times 100\%}$$

where ρ = density of the existing water vapour
 ρ_0 = density of saturated water vapour

Since a vapour obeys gas laws from unsaturated state up to the just saturated state, the perfect gas equation $pV = \frac{m}{M}RT$ becomes applicable.

Re- adjusting this equation $P = \frac{m}{V} \cdot \frac{RT}{M} = \rho \frac{RT}{M}$

$$p = \left(\frac{RT}{M} \right) \rho$$

Hence it is clear that when T and M are constant. $p \propto \rho$
 thus the ratio of densities can be replaced as,

$$\frac{\rho}{\rho_0} = \frac{p}{p_0}$$

$$\therefore \boxed{RH = \frac{P}{P_0} \times 100\%}$$

where p = vapour pressure at the given temperature
 p_0 = saturated vapour pressure at the same temperature

Worked example

At 27 °C the vapour pressure in a given volume of air is 12 cm Hg. Calculate the relative humidity of air inside this volume. What will be the new relative humidity if the room temperature is brought to 40 °C. The saturated vapour pressures at 27 °C and 40 °C are 20 cm Hg and 24 cm Hg respectively.

$$\begin{aligned} \text{Vapour pressure at } 27^\circ\text{C} & \quad p_{27} = 12 \text{ cm Hg} \\ \text{Saturated vapour pressure at } 27^\circ\text{C} & \quad p_{s27} = 20 \text{ cm Hg} \end{aligned}$$

$$\therefore RH = \frac{P}{P_0} \times 100$$

$$RH = \frac{12}{20} \times 100 = 60\%$$

\therefore At 27 °C the relative humidity in the volume of air = 60%

To find the vapour pressure p_{40} when the temperature is raised to 40 °C, Charles's pressure law can be used. $\frac{P_1}{T_1} = \frac{P_2}{T_2}$

$$\text{Substituting } \frac{P_{40}}{T_{40}} = \frac{P_{27}}{T_{27}}$$

$$= \frac{P_{40}}{313} = \frac{12}{300} \Rightarrow p_{40} = \frac{313}{300} \times 12 = 12.52 \text{ cm Hg}$$

saturated vapour pressure at 40 °C, $p_{s40} = 24 \text{ Hg cm}$

$$\text{Relative humidity } RH = \frac{p_{40}}{P_{s40}} \times 100 = \frac{12.52}{24} \times 100\% = \underline{\underline{52.2\%}}$$

Dew point

Unsaturated vapour in a given volume of air can be converted to saturated vapour in two ways. One way is to add more water vapour into the given volume of air until it gets saturated. The other way is by reducing its temperature to reach the saturation point.

The vapour molecules in a given unsaturated vapour are in random motion and when the temperature is reduced the kinetic energy of the vapour molecules gets reduced. When the temperature is further reduced in this manner, certain vapour molecules having low kinetic energy being unable to exist in the vapour zone get deposited on the walls of the container. This state is equivalent to the saturated state of a vapour when the temperature keeps on reducing. The temperature at which the volume of air gets saturated for the first time with water vapour existing in it, is known as the dew point of that volume of air. The dew point of a given volume of air depends on vapour density in the volume and can be equal to less than or more than the room temperature.

The deposition of dew on a cool drink bottle taken out for refrigerator also takes place in the manner described above. The cool drink bottle absorbs heat from the surroundings and there by reduces the temperature of surrounding air. Then the water vapour in air close to the drink bottle gets saturated and the deposition of dew on the bottle can be observed.

Chapter - 08

Thermodynamics

Heat flows from where there is higher temperature to where there is lower temperature. In thermodynamics, heat is considered to be energy in transit. Heat is not a form of energy that can be stored in a body.

So we must think of heat in the same way as we think of work. Work is not stored. If work is done on an object its energy (kinetic energy and potential energy) increases. If the work is done by the object its energy decreases. In general, when heat is supplied to an object it can be expected that its internal energy (kinetic energy and potential energy) may increase. When heat is emitted (lost) from an object, its internal energy decreases.

In an ideal gas internal energy appears only in the form of kinetic energy. (There are no intermolecular forces in a gas and hence there is no potential energy.) Therefore, for an ideal gas (approximately for all gases), when heat is supplied, if its temperature rises, then its kinetic energy increases. Then its internal energy increases. When heat is lost from the gas, if its temperature decreases, then its kinetic energy decreases. As a result, its internal energy decreases.

The first law of thermodynamics

In a system, if the net exchange of heat is ΔQ , the change of internal energy is ΔU and the amount of work done is ΔW then,

$$\Delta Q = \Delta U + \Delta W$$

Above three quantities have their signs according to a convention as follows,

<i>Quantity (Change)</i>	<i>Sign</i>
Supply of heat to the system	+ ΔQ
Loss of heat from the system	- ΔQ
Increase of internal energy	+ ΔU
Decrease of internal energy	- ΔU
Work done by the system	+ ΔW
Work done on the system	- ΔW

Application of this law to gases

1. Constant pressure process - $[p]$

A process occurred under a constant pressure

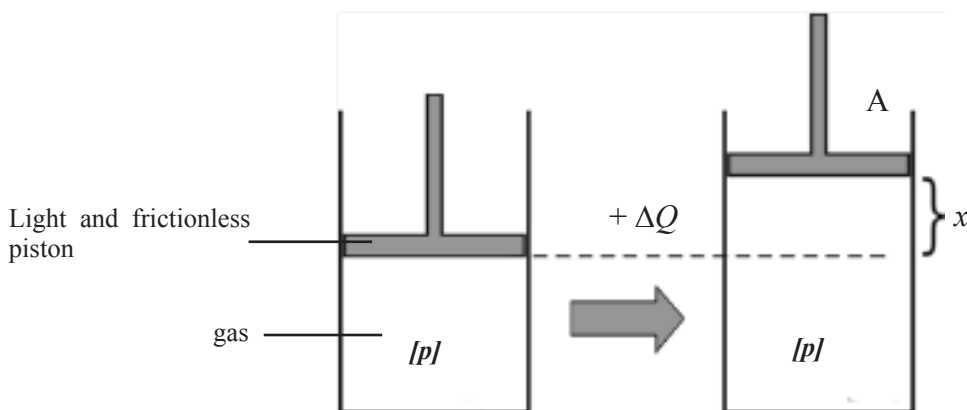

Figure 8.1

Consider a case where an ideal gas is confined to a cylinder using a light frictionless piston as shown in Figure 8.1.

When heat is supplied to above system under constant pressure, the piston raises,

A - cross sectional area of the piston

x - distance by which the piston is raised

$$\begin{aligned} \text{Increase of volume of gas} &= Ax = \Delta V \\ \text{Pressure on the piston} &= p \\ \therefore \text{Force on the piston} &= p.A \\ \text{Work done by the gas} &= p.A.x = p.Ax = p.\Delta V \end{aligned}$$

In this example ΔV is positive (+ve) .

Because the gas has expanded and the work is done by the gas.

Consider a situation where ΔV is negative (-ve) .

Then the gas has contracted and the work is done on the gas (by the external thrust force due to outside pressure)

Note that,

When the volume of a gas increases is ΔW is +ve.

When the volume of a gas decreases is ΔV is -ve.

In any of the above cases,

$$\Delta W = p.\Delta V \text{ (under constant pressure)}$$

The 1st law of thermodynamics

$$\Delta Q = \Delta U + \Delta W$$

Now becomes $\Delta Q = \Delta U + P.\Delta V$

Under constant pressure p

When ΔQ is +ve, (i.e. If heat is supplied to the system)

ΔU is -ve, is (i.e. temperature increases)

$p.\Delta V$ is also +ve (i.e. work is done by the gas)

When ΔQ is -ve, (i.e. If heat is lost from the system)

ΔU is -ve is, (i.e. temperature decreases)

$p.\Delta V$ is also -ve (i.e. work is done on the gas by external forces)

2. Constant volume process [$\Delta V=0$]

This is a process occurred under constant volume.

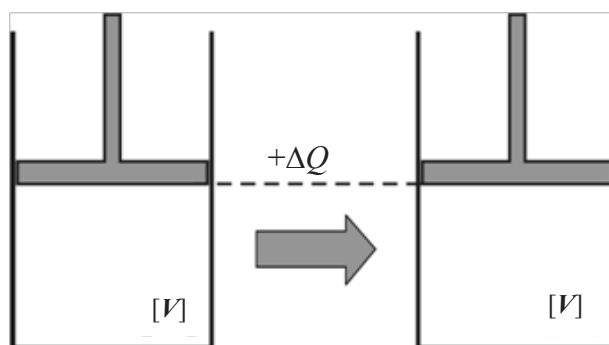

Figure 8.2

Under constant volume, no work is done by the gas or done on the gas. (i.e. $\Delta W = 0$ as there is no change of volume.)

The 1st law $\Delta Q = \Delta U + \Delta W$

Now becomes $\Delta Q = \Delta U + 0$

$$\therefore \Delta Q = \Delta U$$

When heat is supplied to the system,

ΔQ is +ve, and hence ΔU is -ve (temperature increases)

When heat is lost from the system,

ΔQ is -ve, and hence ΔU is -ve (temperature decreases)

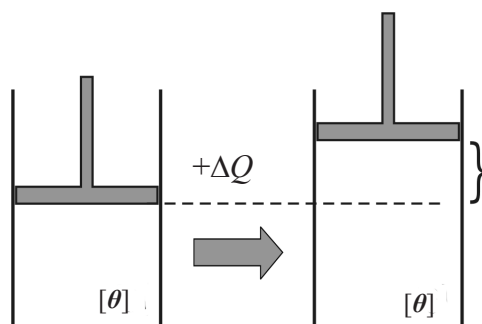

Figure 8.3

3. Isothermal process [θ]

This is a process occurred keeping the temperature constant.

Practically a very slow process is an isothermal process. Slow process allows the system to be in thermal equilibrium with the environment which is almost at a constant temperature. So the temperature of the system is always constant, i.e. it is at the environmental temperature.

For the isothermal process

$$\Delta\theta = 0 \text{ as temperature is constant)}$$

$$\therefore KE = 0 \text{ (as } KE \propto \theta \text{ in kelvin)}$$

$$\therefore \Delta U = 0 \text{ (for an ideal gas internal energy is totally kinetic energy)}$$

i.e. Internal energy of the system is constant.

The 1st law $\Delta Q = \Delta U + \Delta W$

Now becomes, $\Delta Q = \Delta W$

If ΔQ is +ve, then ΔW will also be +ve (i.e. work is done by the system).

If ΔQ is -ve, then ΔW will also be -ve (i.e. work is done by the system).

4. Adiabatic process [$\Delta Q = 0$]

This is a process in which there is no net transfer of heat between the system and the outside. Therefore, $\Delta Q = 0$.

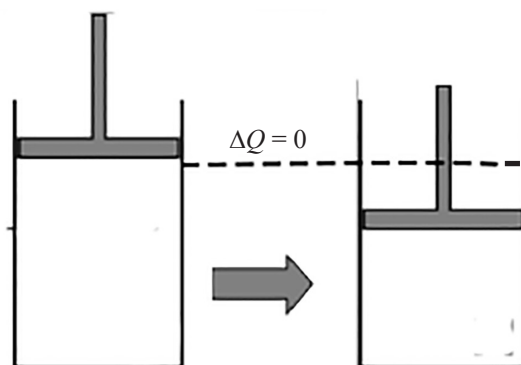

Figure 8.4

Practically, a quick process is an adiabatic process. A process taken place within a very short period of time, doesn't allow the system to transfer any heat. Because transfer of heat requires some finite duration of time.

The 1st law $\Delta Q = \Delta U + \Delta W$

Now becomes $0 = \Delta U + \Delta W$

$$\therefore \Delta U = -\Delta W \text{ or } -\Delta U = \Delta W$$

If ΔW is +ve (i.e. if the gas expands), we use $-\Delta U = \Delta W$

Then ΔU is -ve.

Therefore, sudden expansion of a gas causes decrease in internal energy (U). Hence decrease in temperature.

If ΔW is -ve (ie. if the gas contracts), we use $-\Delta U = \Delta W$

Then ΔU is +ve.

So sudden compression of a gas causes increase in internal energy (U). Hence, increase in temperature.

- eg. :-
1. When a bicycle tyre is being inflated using an inflator, we observe an increase in temperature of the valve of the tube. This is due to the sudden compression of air at the valve.
 2. When the valve of an inflated tyre is opened, we observe that the out coming air and the valve become cool. This is due to the sudden expansion of out coming air.

Pressure - volume (p - V) curves (for ideal gases)

We can plot the graph of pressure against volume for a fixed mass of an ideal gas. This type of graph is known as pressure – volume (p - V) curves or graphs. An arrow head is marked on the graph to indicate the starting point and the end point.

If we increase the volume of a fixed mass of gas under constant temperature, its pressure decreases (Boyles' law). This is shown by the p - V graph in Figure 8.5.

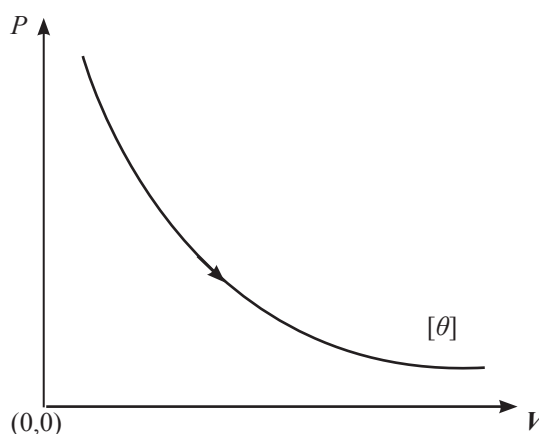

Figure 8.5

If the temperature of the gas is also a variable then the curve can get any shape.

Under constant temperature, the pressure of the gas decreases with increase of volume as shown above. If the temperature is also varied appropriately while increasing the volume, the pressure can be made increasing decreasing or remain constant. So, it can be understood that the p - V curve can have any shape such as shown in Figure 8.6, depending on variation of temperature.

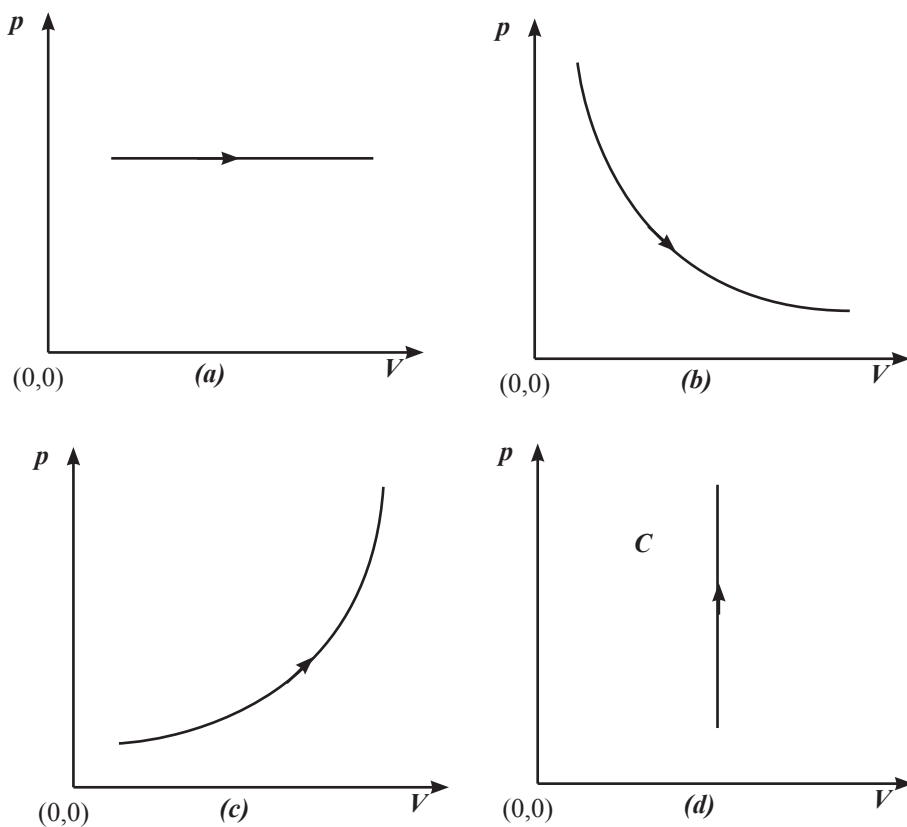

Figure 8.6

Graph (a) represents a constant pressure process.

Graph (b) represents a constant temperature (isothermal) process.

Graph (c) represents a process where all three parameters volume, pressure and temperature are varying.

Graph (d) represents a constant volume process

Work done and p - V curve

Consider a constant pressure process

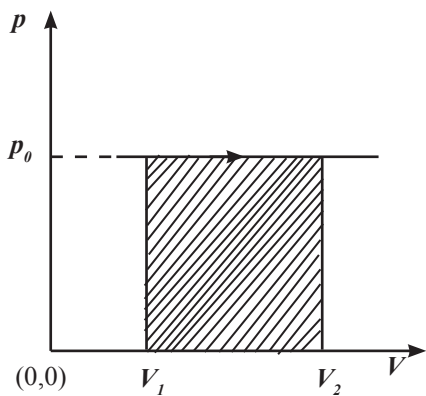

Figure 8.7

The work done during the process (shown in Figure 8.7) where volume increases from V_1 to V_2 under constant pressure p_0 is given by $p_0 \cdot \Delta V$, Hence $\Delta V = V_2 - V_1$

$$\Delta W = p_0(V_2 - V_1)$$

$$\Delta W = p_0 \Delta V$$

Since $p_0(V_2 - V_1)$ is the area of the shaded rectangle in the above graph, it is clear that the work done is given by the area under the relevant part of the curve.

By applying similar argument, it can be shown that the area under any $p - V$ curve gives the relevant ΔW .

Consider the process shown by the $p - V$ curve in Figure 8.8.

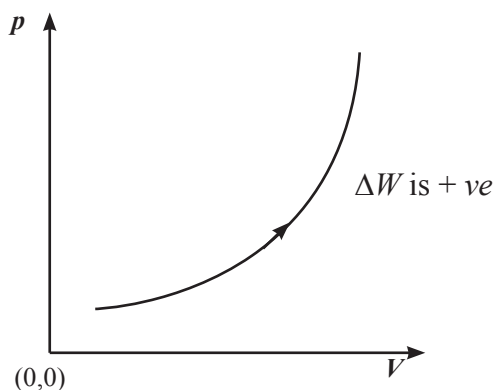

Figure 8.8

This process increases the volume of the gas (the direction of the arrow indicates that the volume is increasing).

When the volume of a gas increases (i.e. when the gas expands) ΔW is + ve.

Consider the process shown by the $p - V$ curve in Figure 8.9.

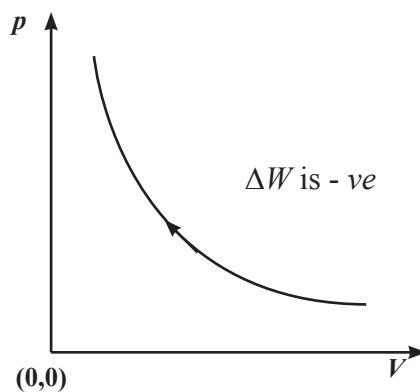

Figure 8.9

The arrow head on the graph indicates that the volume of the gas is decreasing. To decrease volume, work should be done on the gas by external forces. Therefore, when the volume of a gas decreases ΔW is - ve.

Cyclic process

If a system returns to its starting point after going through several processes, it is called a cyclic process.

The $p - V$ curve shown in Figure 8.10, represents a cyclic process. The starting point of the process is A. The end point is also A.

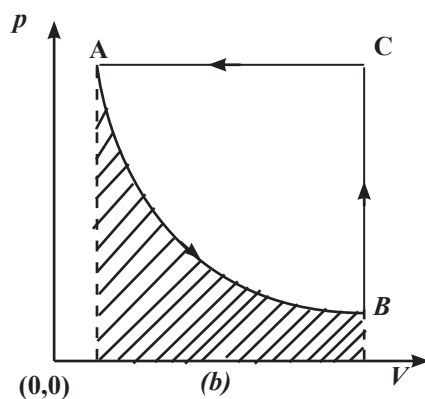

Figure 8.10

Process from A to B

In this process volume is increasing and therefore, ΔW is +ve and is given by the shaded area (area under AB).

Process from B to C

In this process there is no change of volume. Therefore, $\Delta W = 0$.

Process from C to A

In this process volume is decreasing. Therefore, ΔW is -ve and is given by the area under AC.

For the whole cyclic process,

$$\begin{aligned} \Delta W &= \Delta W_{AB} + \Delta W_{BC} + \Delta W_{CA} \\ &= \text{area under AB} + 0 - \text{area under CA} \\ &= (\text{area under CA} - \text{area under AB}) \\ &= - \text{area ABC} \end{aligned}$$

So it can be concluded that for a cyclic process the magnitude of ΔW is given by the area enclosed by the curve. The sign of ΔW is determined by the summation of all +ve ΔW 's and all -ve ΔW 's.

In this example, magnitude of the $-ve \Delta W$'s is larger than the magnitude of $+ve \Delta W$'s
Therefore, ΔW for the above cyclic process is $-ve$.

Consider the cyclic process shown in Figure 8.11.

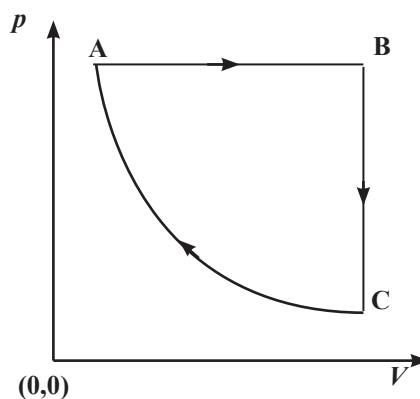

Figure 8.11

This is similar to the process shown in Figure 8.10 except the fact that this cyclic process is clockwise while the previous is anti-clockwise.

In this cyclic process,

$$\Delta W_{AB} \text{ is } +ve$$

$$\Delta W_{BC} = 0$$

$$\Delta W_{CA} \text{ is } -ve$$

for the whole cyclic process,

$$\begin{aligned} \therefore \Delta W &= \Delta W_{AB} + \Delta W_{BC} + \Delta W_{CA} \\ &= \text{area under AB} + 0 - \text{area under CA} \\ &= + \text{area ABC} \end{aligned}$$

Therefore, ΔW for this cyclic process is $+ve$.

Hence it is clear that in a clockwise cyclic process, ΔW is $+ve$ and in an anti-clockwise cyclic process ΔW is $-ve$.

Chapter - 09**Transfer of heat**

There are three ways of transferring heat. Those are,

1. Conduction
2. Convection
3. Radiation

Conduction of heat

The property of transferring heat from one particle to another without any movement of the particles (as a whole) in a medium, is known as conduction of heat.

Conduction of heat can be explained by two mechanisms.

- (1) This applies to materials with a supply of free electrons (e.g. metals). Free electrons gain energy due to temperature rise of the material and then their velocities increase. They are able to move over larger distances and pass on energy quickly to cooler parts.
- (2) Materials which do not have enough free electrons, the atoms at higher temperature vibrate more vigorously in the lattice than their colder neighbours. As they are coupled by inter-atomic bonds, they pass on some of their vibratory energy to colder atoms enabling them to vibrate more energetically as well. These in turn affect other atoms and thermal conduction occurs.

It can be explained by the mechanism (1) above, that good electrical conductors are also good heat conductors because of the availability of free electrons.

Conduction of heat along a rod

We can get an idea of how heat conducts along a conducting rod by doing the following activity.

Steps

- (1) Get a metal rod with the diameter of about 5 – 10 mm and length nearly 20 cm (a long screw driver may be used).

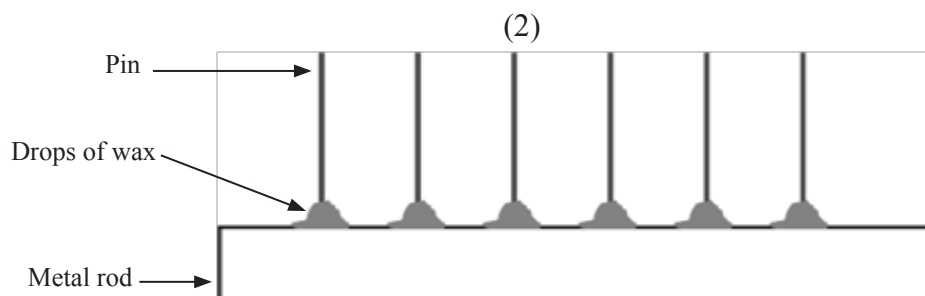

Figure 9.1

- (2) Place several pins at equal distances along the rod using candle wax as shown in the diagram. The pointed ends of the pins should be directed outwards.
- (3) Hold the rod at one end using a pair of pliers or a piece of cotton cloth and rotate it, so that the pins are directed downwards. Then heat the other end of the rod using a flame (Figure 9.2).

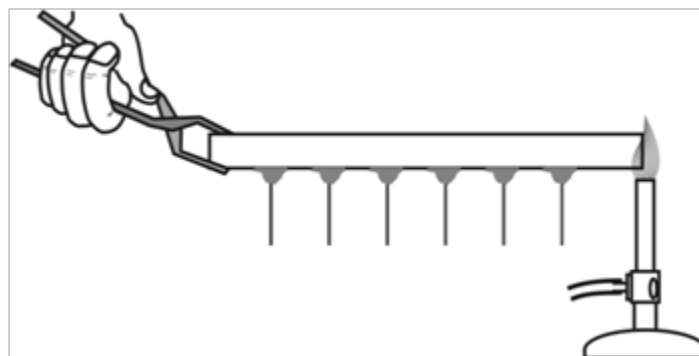

Figure 9.2

- (4) Observe whether there is any order (sequence) of dropping down the pin and try to get an idea of how heat flows along a rod.

Conduction when the rod is lagged.

When the curved surface of the rod is covered with a heat insulating material, the rod is said to be lagged. Lagging is usually represented as follows (Figure 9.3).



Figure 9.3

When heat is supplied to one end of the rod, lagging ensures that the heat flow is axial along the rod. This is because no heat can flow through the curved surface. This axial flow is indicated using arrows as shown in Figure 9.4.

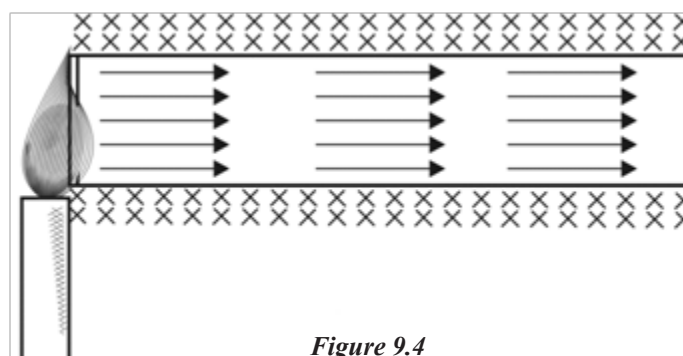

Figure 9.4

To measure temperature at various points on the rod, it should be made with small cavities on the rod at the required points (Figure 9.5).

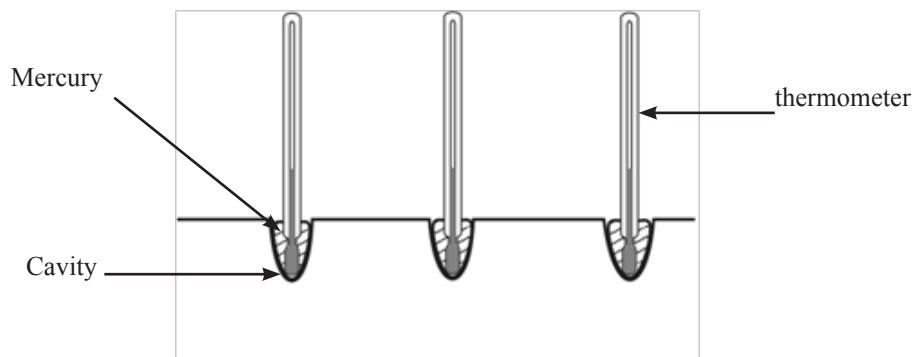

Figure 9.5

These cavities are filled with mercury and bulb of each thermometer is immersed in the mercury. This improves better thermal contact between the rod and the bulb of the thermometer.

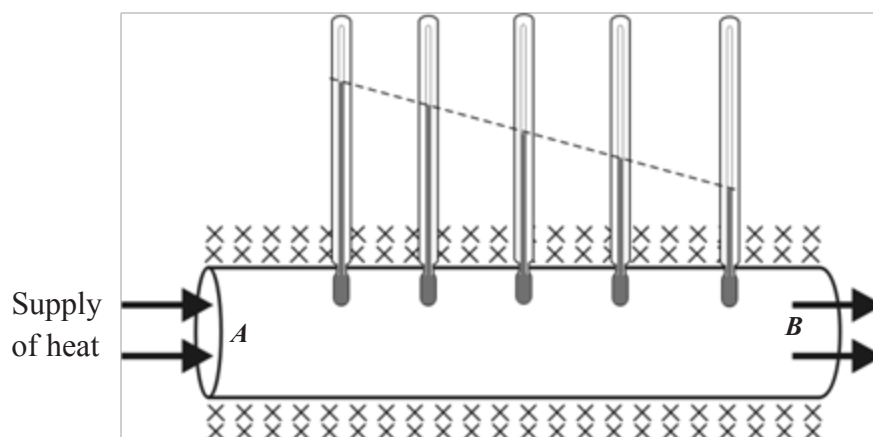

Figure 9.6

The end A of the rod is heated with a source of heat at constant temperature (Figure 9.6). Then the readings of the thermometers increase and after some period of time a stage is reached where there is no further change of the readings of the thermometers. This is known as steady state. i.e. An object is in steady state when the temperatures of all points in it are steady.

To decide that a particular point is in steady state, the temperature reading of that point should remain unchanged at least for about 30 seconds.

When a rod which is lagged is conducting heat in the steady state. The graph of temperature (θ) vs. distance from the heating end (l) is as follows (Figure 9.7).

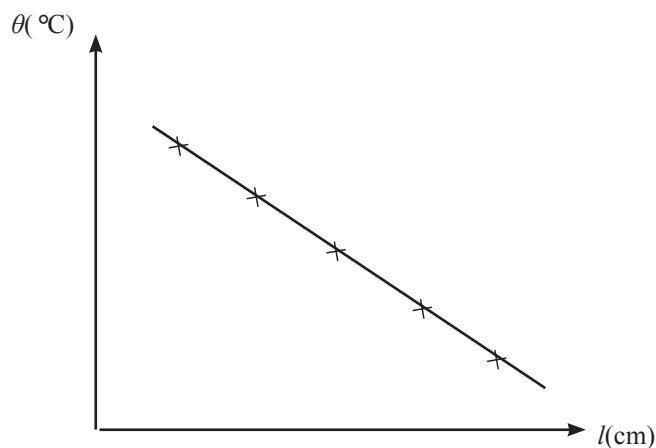

Figure 9.7

This shows that the temperature gradient is constant. The temperature gradient is $\Delta\theta/\Delta l$ and is given by the gradient of the graph. In the steady state of flow of heat, the temperature gradient along the axis of a rod which is lagged is constant.

Conduction when the rod is not lagged

When the rod is not lagged (i.e. when the flow of heat is not axial) the graph of θ vs. l in the steady state is as follows (Figure 9.8).

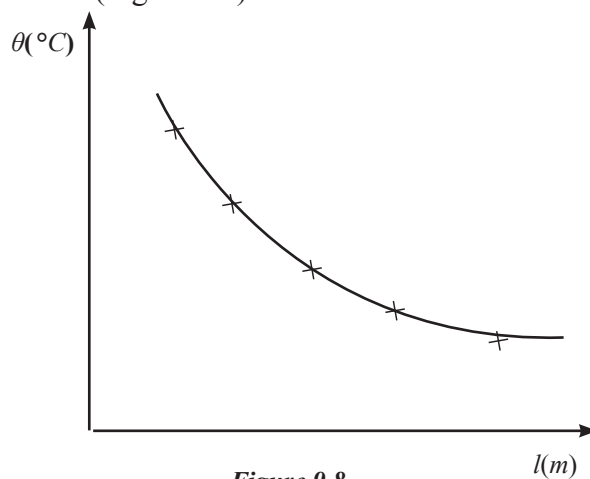

Figure 9.8

When the rod is not lagged, the temperature gradient along the rod is not constant. This is due to the fact that heat transfers from the rod to the surroundings through the curved surface of it, resulting that, the flow of heat is not axial. This is shown in Figure 9.9. This leads to the curved shape of the graph θ vs l .

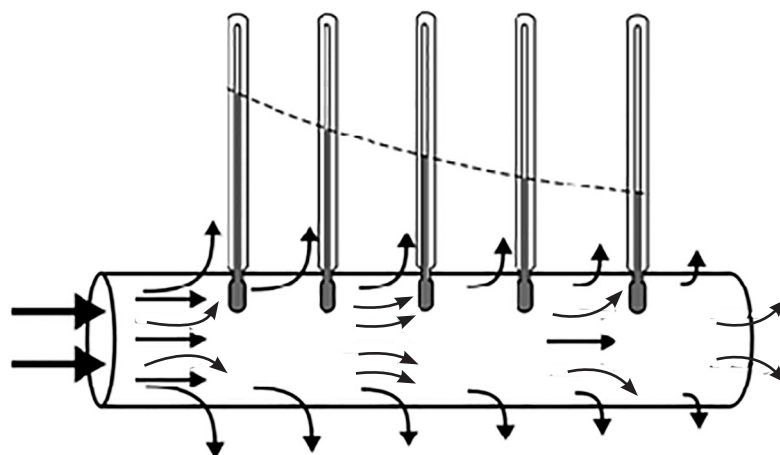

Figure 9.9

Thermal conductivity

Let us consider conduction of heat along a rod which is lagged.

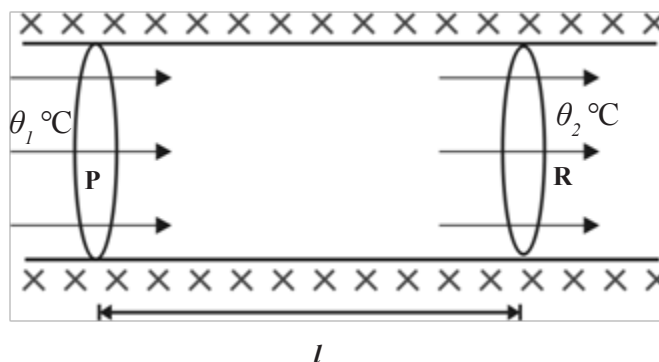

Figure 9.10

In the steady state, the rate of flow of heat through any cross section like P or R should be the same because the flow of heat is axial.

It has been shown experimentally when the rod is lagged, that the rate of flow of heat $\frac{\Delta Q}{\Delta t}$ in the steady state, is proportional to,

- (1) The cross sectional area of the rod (A)
- (2) The temperature gradient along the rod $\frac{\Delta\theta}{\Delta l}$

where θ_1 and θ_2 are the temperatures at P and R respectively.

Therefore, $\frac{\Delta Q}{\Delta t} \propto A \left(\frac{\Delta\theta}{\Delta l} \right)$

$$\therefore \frac{\Delta Q}{\Delta t} \propto \frac{A(\theta_1 - \theta_2)}{l}$$

$$\frac{\Delta Q}{\Delta t} = K \frac{A(\theta_1 - \theta_2)}{l}$$

where θ_1 and θ_2 are the temperatures at P and R respectively.

The proportionality constant K here is known as the thermal conductivity of the material of the rod.

$$\text{Now, } \therefore K = \frac{\left[\frac{\Delta Q}{\Delta t} \right]}{\left[A \right] \left[\frac{\theta_1 - \theta_2}{l} \right]}$$

Therefore, K is the rate of flow of heat per unit cross sectional area and per unit temperature gradient.

$$\text{Units of } K = \frac{\text{W}}{\text{m}^2 \text{K/m}} = \frac{\text{W}}{\text{m K}} = \text{W m}^{-1} \text{K}^{-1}$$

$$\text{Dimensions of } K = \frac{\left[\frac{\Delta Q}{\Delta t} \right]}{\left[A \right] \left[\frac{\theta_1 - \theta_2}{l} \right]} = \frac{ML^2T^{-3}}{L^2 \cdot \frac{\theta}{L}} = \frac{MLT^{-3}}{\theta} = MLT^{-3}\theta^{-1}$$

(θ here has been taken as the dimension symbol for temperature)

Convection of heat

Convection is the process in which heat is transferred through a fluid by the movement of the fluid particles itself.

If a beaker containing a liquid is heated from underneath, the liquid at the bottom becomes warmer than that above it. As for liquids, in general, their densities fall with rise of temperature. So the heated liquid at the bottom, raises to the top and cooler liquid from above, moves downwards. On reaching the bottom, this also becomes heated and moves upwards. Continuation of this process forms a circulating currents of liquid called convection currents.

Convection can occur in both liquids and gases and clearly it cannot occur in solids. The occurrence of convection currents can be shown by the following activity (Figure 9.11).

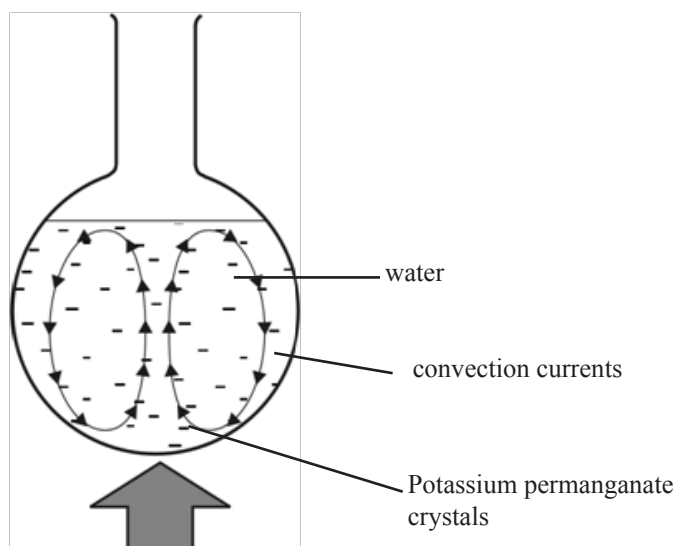

Figure 9.11

Put some water in a large round bottom flask. Place an open tube in the water vertically, with one end above and the other end at the bottom of the flask. Drop some potassium permanganate crystals into it. Then put one finger over the top end and remove the tube, leaving the crystals on the bottom of the flask. Place a small bunsen flame underneath the crystals. Then purple streamers rise gently up the middle of the liquid and then fall down close to the wall of the flask. Thus a convection current has been set up.

Radiation of heat

Radiation of heat can be described as being electromagnetic radiation emitted by a body solely on account of its temperature. This radiation spans a continuous range of wavelengths depending on the temperature of the emitter. At temperatures below about $1000\text{ }^{\circ}\text{C}$, the energy is associated almost entirely with infrared wavelengths. At higher temperatures than this visible and ultraviolet wavelengths are also involved.

This radiation of heat can not be deflected by mere electric and magnetic fields. It travels at a speed of $3 \times 10^8\text{ m s}^{-1}$ in a vacuum. The intensity of the radiation produced by a point source falls off with the distance from the source in accordance with the inverse square law.

Radiation of heat can be demonstrated as follows.

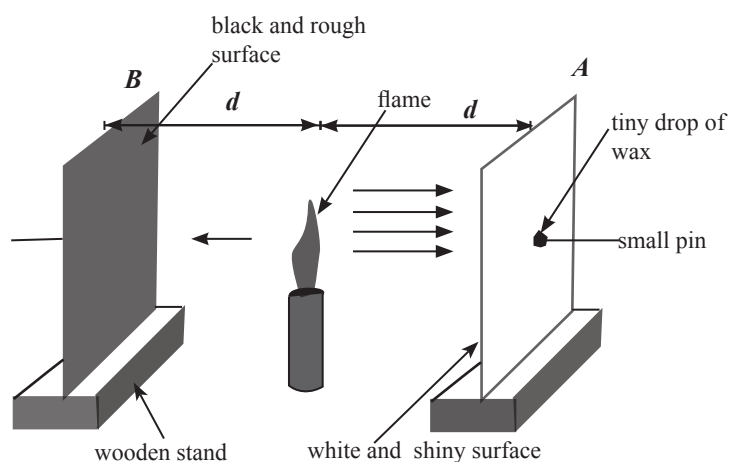

Figure 9.12

A and B are two identical sheets of copper of dimensions nearly 3×4 cm. A is painted shiny white and B matt black. On the back of each plate is a drop of wax which supports a small pin. Place a suitable flame midway between the two plates which are about 10 cm apart ($d = 5$ cm). The flame should be at the same level as the drops of wax.

It can be observed that the pin on B falls after some time and the pin on A falls later. Heat arrived at both A and B by means of radiation because hot convection currents are only upwards and negligible conduction is there as air is a bad conductor. This also shows that black rough surface absorbs heat radiation more quickly than shiny white surface.

Worked examples

- (1) A lagged compound bar of length 25 cm consists of copper bar of length 15 cm joined to an aluminum bar of length 10 cm long. The two bars are of equal cross-sectional area. The free end of the copper bar is maintained at 100°C and the free end of the aluminum bar is at 0°C .

(thermal conductivity of copper = $390 \text{ W m}^{-1} \text{ K}^{-1}$ and that of aluminum = $210 \text{ W m}^{-1} \text{ K}^{-1}$)

- (i) Are the rates of flow of heat through copper and aluminum bars equal? Give reasons.
- (ii) Take the temperature at the joint as $\theta^\circ\text{C}$ and write an expression for the temperature gradient of
 - (a) copper bar
 - (b) aluminum bar
- (iii) Taking the cross sectional area of the bar as A , write an expression for the rate of transfer of heat of
 - (a) copper bar
 - (b) aluminum bar

- (iv) Considering your answer for part (i) above, write an equation and calculate the value of θ .

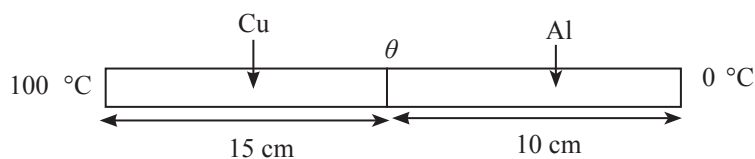

Answer

- (i) Yes, because the flow of heat is axial along the bar as it is lagged.

(ii) a) $\frac{100 - \theta}{15 \times 10^{-2}}$

b) $\frac{\theta - 0}{10 \times 10^{-2}}$

(iii) a) $390 \times A \times \frac{(100 - \theta)}{15 \times 10^{-2}}$

b) $210 \times A \times \frac{\theta}{10 \times 10^{-2}}$

$$390 \times A \times \frac{(100 - \theta)}{15 \times 10^{-2}} = 210 \times A \times \frac{\theta}{10 \times 10^{-2}} \quad \frac{1}{9} K$$

(iv) $\therefore \frac{39(100 - \theta)}{15} = \frac{21 \times \theta}{10}$

$$\therefore 39000 - 390\theta = 315\theta$$

$$705 \times \theta = 39000$$

$$\theta = \frac{39000}{705}$$

$$\theta = \underline{\underline{55.3 \text{ } ^\circ\text{C}}}$$

- (2) A vessel having an effective surface area of 250 cm² and walls 2 mm thick is filled with lumps of ice mixed with water at normal pressure and then placed in a water-bath maintained at 95 °C.

What mass of ice will melt per minute when conditions become steady?

Latent heat of fusion of ice = $3.36 \times 10^5 \text{ J kg}^{-1}$, thermal conductivity of the material of the vessel = $0.84 \text{ W m}^{-1} \text{ K}^{-1}$.

Answer

$$\frac{Q}{t} = KA \frac{(\theta_1 - \theta_2)}{l}$$

$$\therefore \frac{Q}{t} = 0.84 \times 250 \times 10^{-4} \times \frac{(95 - 0)}{2 \times 10^{-3}}$$

$$\therefore \text{Heat transferred per minute} = \frac{0.84 \times 250 \times 10^{-4} \times 95}{2 \times 10^{-3}} \times 60$$

$$\text{Heat required to melt 1 kg of ice} = 3.36 \times 10^5 \text{ J}$$

$$\therefore \text{Mass of ice melted per minute} = \frac{(0.84 \times 250 \times 10^{-4} \times 95 \times 60) / 2 \times 10^{-3}}{3.36 \times 10^5} = \underline{\underline{0.1781 \text{ kg} = 178.1 \text{ g}}}$$

- (3) The temperature inside a boiler is 105°C . The wall of the boiler is 2 cm thick and is lagged with 4 cm thickness of a material whose thermal conductivity is $\frac{1}{9}$ of that of the material of the boiler. At the steady state the temperature of the outside surface of the lagging in contact with the air is 10°C . What is the temperature of the common surface of the boiler and the lagging?

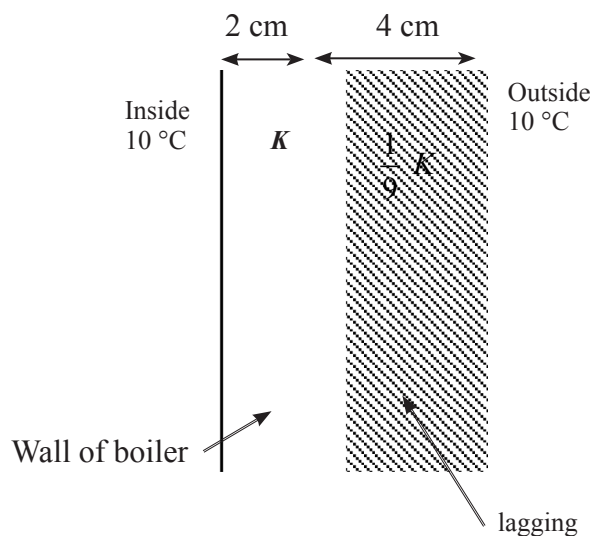

Assume that the thermal conductivity of the material of the boiler is K (in SI units),

\therefore The thermal conductivity of the lagging material is $\frac{1}{9} K$

Consider a surface area A of the boiler

Then,

$$\left(\frac{Q}{t}\right)_{\text{through the wall}} = \left(\frac{Q}{t}\right)_{\text{through the lagging}}$$

$$\therefore K \frac{A(105 - \theta)}{2 \times 10^{-2}} = \frac{1}{9} K \frac{A(\theta - 10)}{4 \times 10^{-2}}$$

(where θ is the temperature of the common surface)

$$\begin{aligned}\therefore \frac{(105 - \theta)}{2} &= \frac{(\theta - 10)}{9 \times 4} \\ \therefore 18(105 - \theta) &= (\theta - 10) \\ \therefore 1890 - 18\theta &= \theta - 10 \\ \therefore 19\theta &= 1900 \\ \therefore \theta &= \frac{1900}{19} = \underline{\underline{100}} \text{ } ^\circ\text{C}\end{aligned}$$

References:

Breithaupt, J. (2003). *Understanding Physics For Advanced Level - Fourth Edition*. Nelson Throne, Cheltenham, UK.

Edmonds Jr., D. S. (1993). *Cioffari's Experiments in College Physics -Ninth Edition*. D. C. Heath and Company, Massachusetts, USA.

Muncaster, R. (1993). *A-level Physics - Fourth Edition*. Stanley Thornes (Publishers) Ltd, Cheltenham, UK.

Nelkon, M. & Ogborn, J. M. (1987). *Advanced Level Practical Physics - Fourth Edition*. Heinemann Educational Books, London, UK.

Tyler, F. (1961). *A Laboratory Manual of Physics - Second Edition*. Edward Arnold Publishers Limited, London, UK.